

**Qwest Corporation**  
**Access Service**  
**Catalog No. 1**

**SECTION 6**  
Index Page 1  
Release 1  
Effective: 8-1-05

**NORTHERN IDAHO**  
Issued: 7-1-05

**6. SWITCHED ACCESS SERVICE**

<b>SUBJECT</b>	<b>PAGE</b>
800 Database Access Service .....	55
900 Access Service .....	59
Acceptance Testing .....	32
Application of Rates for Extension Service.....	117
Assumed Minutes of Use for Feature Group A .....	112
Change of Switched Access Service Type .....	103
Common Switching and Transport Termination Optional Features.....	62
Common Switching Optional Features .....	62
Description and Application of Rates and Charges .....	86
Design and Traffic Routing of Switched Access Service.....	78
Design Blocking Probability.....	80
Design Layout Report .....	31
Design of Switched Access Services .....	85
Determination of Number of End Office Transport Terminations .....	80
Determination of Number of Transmission Paths .....	79
Diagrams of Service.....	5
DS1 Records Assignment .....	78
Facilities Protection-Special Facilities Routing.....	31
Feature Group A (FGA).....	34
Feature Group B (FGB) .....	40
Feature Group C (FGC) .....	43
Feature Group D (FGD).....	49
General .....	1
Interface Groups .....	20
Local Information Delivery Services.....	117
Local Switching .....	29

**NOTICE**  
**THE INFORMATION CONTAINED IN THIS DOCUMENT IS SUBJECT TO CHANGE.**

**Qwest Corporation**  
**Exchange and Network Services**  
**Catalog No. 1**

**SECTION 6**  
Index Page 2  
Release 1  
Effective: 8-1-05

**NORTHERN IDAHO**  
Issued: 7-1-05

**6. SWITCHED ACCESS SERVICE**

<b>SUBJECT</b>	<b>PAGE</b>
Manner of Provision .....	2
Measuring Access Minutes .....	110
Message Unit Credit Allowance .....	139
Message Unit Credit .....	117
Mileage Measurement .....	118
Minimum Monthly Charge .....	102
Minimum Periods .....	102
Moves .....	104
Multiplexing .....	78
Network Management .....	77
Obligations of the Company .....	77
Obligations of the Customer .....	83
Ordering Options and Conditions .....	32
Ordering Requirements .....	83
Percent Direct Routed (PDR) Factor .....	122
Provision and Description of Switched Access Service .....	33
Provision of Service Performance Data .....	79
Rate Categories .....	4
Rate Regulations .....	86
Monthly Rates .....	86
Nonrecurring Charges .....	87
Service Rearrangements .....	88
Usage Rates .....	86
Rates and Charges .....	123

**NOTICE**  
**THE INFORMATION CONTAINED IN THIS DOCUMENT IS SUBJECT TO CHANGE.**

**Qwest Corporation**  
**Exchange and Network Services**  
**Catalog No. 1**

**SECTION 6**  
Index Page 3  
Release 1  
Effective: 8-1-05

**NORTHERN IDAHO**  
Issued: 7-1-05

**6. SWITCHED ACCESS SERVICE**

<b>SUBJECT</b>	<b>PAGE</b>
Report Requirements .....	84
Code Screening Reports.....	84
900 NXX Code Reports .....	84
Jurisdictional Reports .....	84
Multiple POTs Tandem Sectorization Reports.....	84
Shared Use .....	121
Supervisory Signaling.....	85
Switched Access Service Arrangements and Manner of Provision.....	2
Switched Transport .....	14
Terminating FX/ONAL .....	122
Traffic Types.....	2
Transmission Specifications .....	76
Transport Termination Optional Features.....	74
Trunk Group Measurement Reports - Company .....	79
Trunk Group Measurement Reports - Customer .....	85
WATS Access Service (WATS).....	69

NOTICE  
THE INFORMATION CONTAINED IN THIS DOCUMENT IS SUBJECT TO CHANGE.

**Qwest Corporation**  
**Access Service**  
**Catalog No. 1**

**SECTION 6**  
Page 1  
Release 1  
Effective: 8-1-05

**NORTHERN IDAHO**  
Issued: 7-1-05

---

**6. SWITCHED ACCESS SERVICE**

**6.1 GENERAL**

Switched Access Service, which is available to customers for their use in furnishing their services to end users, provides a two-point electrical communications path between a customer's premises and an end user's premises. It provides for the use of terminating, switching and transport facilities and common subscriber plant of the Company. Switched Access Service provides for the ability to originate calls from an end user's premises to a customer's premises, and to terminate calls from a customer's premises to an end user's premises in the LATA where it is provided. Specific references to material describing the elements of Switched Access Service are provided in 6.1.1 and 6.1.2, following.

Rates and charges for Switched Access Service are set forth in 6.8, following. The application of rates for Switched Access Service is described in 6.7, following. Rates and charges for services other than Switched Access Service, e.g., a customer's interLATA toll message service, may also be applicable when Switched Access Service is used in conjunction with these other services. Descriptions of such applicability are provided in 6.2.1.A.7., 6.2.1.B.4., 6.2.2.A.7., 6.2.2.B.3., 6.2.3.A.6., 6.2.4.A.4. and 6., 6.7.7 and 6.7.9, following. Finally, a credit is applied against line side Switched Access Service charges as described in 6.7.8, following.

**NOTICE**  
**THE INFORMATION CONTAINED IN THIS DOCUMENT IS SUBJECT TO CHANGE.**

**Qwest Corporation**  
**Exchange and Network Services**  
**Catalog No. 1**

**SECTION 6**  
Page 2  
Release 1  
Effective: 8-1-05

**NORTHERN IDAHO**  
Issued: 7-1-05

---

**6. SWITCHED ACCESS SERVICE**

**6.1 GENERAL (Cont'd)**

**6.1.1 SWITCHED ACCESS SERVICE ARRANGEMENTS AND MANNER OF PROVISION**

Switched Access Services are differentiated by their technical characteristics, e.g., lineside vs. trunkside connection at the Company entry switch, and the manner in which an end user accesses them in originating calling, e.g., with or without an access code.

A. Manner of Provision

1. Lineside Access (FGA) is furnished on a per line basis. Trunkside Access (FGB, FGC and FGD) is furnished in either quantities of trunks or in busy hour minutes of capacity (BHMCs), at the customer's option, as set forth in 5.2, preceding.
2. BHMCs and trunks are differentiated by type and directionality of traffic carried over a Switched Access Service arrangement. Differentiation among traffic types is necessary for the Company to design Switched Access Service to meet the traffic carrying capacity requirement of the customer.
3. There are four major traffic types. These are: Originating, Terminating, CCC Originating and CCC Terminating.
  - Originating traffic type represents access capacity within a LATA for carrying traffic from the end user to the customer.
  - Terminating traffic type represents access capacity within a LATA for carrying traffic from the customer to the end user.

**NOTICE**  
**THE INFORMATION CONTAINED IN THIS DOCUMENT IS SUBJECT TO CHANGE.**

**Qwest Corporation**  
**Access Service**  
**Catalog No. 1**

**SECTION 6**  
Page 3  
Release 1  
Effective: 8-1-05

**NORTHERN IDAHO**  
Issued: 7-1-05

---

**6. SWITCHED ACCESS SERVICE**

**6.1 GENERAL**

**6.1.1 SWITCHED ACCESS SERVICE ARRANGEMENTS AND MANNER OF PROVISION**

A.3. (Cont'd)

- CCC Originating traffic type represents access capacity within a LATA for carrying circuit switched data and/or circuit switched voice traffic on FGD Service equipped with Clear Channel Capability from the end user to the customer.
- CCC Terminating traffic type represents access capacity within a LATA for carrying circuit switched data and/or circuit switched voice traffic on FGD Service equipped with Clear Channel Capability from the customer to the end user.

When ordering capacity for Trunkside Switched Access, the customer must, at a minimum, specify such access capacity in terms of Originating and/or Terminating traffic type, CCC Originating traffic type or CCC Terminating traffic type. Additionally, when ordering capacity for 800 DB Access Service and/or 900 Access Service, the customer must specify 8XX and/or 900 traffic type.

4. Because some customers will wish to segregate their originating FGC, FGD, 800 DB Access Service or 900 Access Service traffic further into separate trunk groups, the Originating traffic type and CCC Originating traffic type are further categorized into Domestic, 8XX, 900 and Operator. Domestic traffic type represents access capacity for carrying only domestic traffic other than 8XX, 900 and Operator traffic; and, 8XX, 900 and Operator traffic type represents access capacity for carrying, respectively, only 8XX, 900 or Operator traffic. When such customer wishes to segregate their traffic as described above, the customer must specify Domestic, 8XX, 900 or Operator traffic type.

**NOTICE**  
**THE INFORMATION CONTAINED IN THIS DOCUMENT IS SUBJECT TO CHANGE.**

**Qwest Corporation**  
**Access Service**  
**Catalog No. 1**

**SECTION 6**  
Page 4  
Release 1  
Effective: 8-1-05

**NORTHERN IDAHO**  
Issued: 7-1-05

---

**6. SWITCHED ACCESS SERVICE**

**6.1 GENERAL (Cont'd)**

**6.1.2 RATE CATEGORIES**

There are three rate categories which apply to Switched Access Service:

- Switched Transport (described in 6.1.2.A., following)
- Local Switching (described in 6.1.2.B., following)
- Common Line (described in Section 3, preceding)

In addition to the three rate categories, there are rate elements applicable to certain Switched Access Services:

- 800 DB Access Service Charges are applicable to 800 DB Access Service provided in conjunction with Trunkside Switched Access Service. The description and application of these charges are set forth in 6.7.1, following.
- 900 Access Service Charges are applicable to 900 Access Service provided in conjunction with Feature Groups C, D and 900 Access Service (FGB-like). The description and application of these charges are set forth in 6.7.1, following.

**NOTICE**  
**THE INFORMATION CONTAINED IN THIS DOCUMENT IS SUBJECT TO CHANGE.**

**Qwest Corporation**  
**Access Service**  
**Catalog No. 1**

**SECTION 6**  
 Page 5  
 Release 1  
 Effective: 8-1-05

**NORTHERN IDAHO**  
 Issued: 7-1-05

**6. SWITCHED ACCESS SERVICE**

**6.1 GENERAL**  
**6.1.2 RATE CATEGORIES (Cont'd)**

The following diagrams depict possible serving arrangements and components of Switched Access Service and the manner in which the components are combined to provide a complete access service. The following diagrams are not intended to depict all serving arrangements available. Common line rate elements are described in Section 3, preceding.

**EXAMPLE 1**

**Switched Access Service Ordered with DS1 EF and TST**



- CP - Customer's Premises
- EF - Entrance Facility[1]
- SWC - Serving Wire Center
- TST - Tandem - Switched Transport includes Tandem Switching and Tandem Transmission
- AT - Access Tandem
- EO - End Office
- LS - Local Switching
- CL - Common Line
- EU - End User
- ↕ - Indicates Rate Elements

[1] Multiplexing equipment is available in the SWC as an optional feature of the EF as described in A.4., following.

**NOTICE**  
 THE INFORMATION CONTAINED IN THIS DOCUMENT IS SUBJECT TO CHANGE.

**Qwest Corporation**  
**Access Service**  
**Catalog No. 1**

**SECTION 6**  
 Page 6  
 Release 1  
 Effective: 8-1-05

**NORTHERN IDAHO**  
 Issued: 7-1-05

**6. SWITCHED ACCESS SERVICE**

**6.1 GENERAL**

**6.1.2 RATE CATEGORIES (Cont'd)**

**EXAMPLE 2**

**Switched Access Service Ordered with DS1 EF and DS1 DTT Facility**

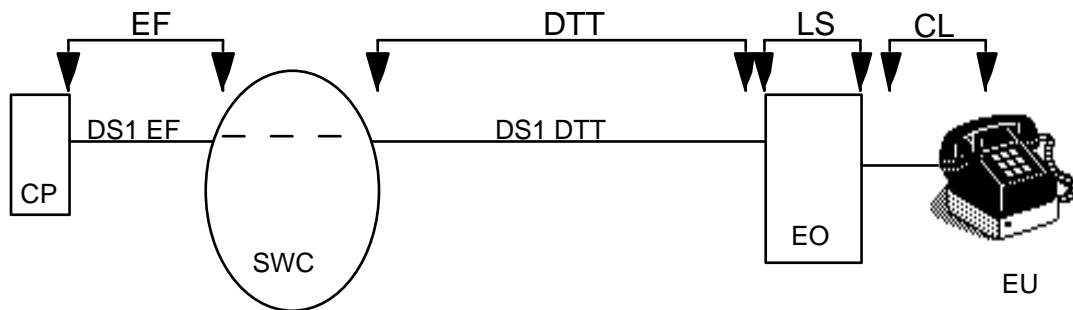

- CP - Customer's Premises
- EF - Entrance Facility
- SWC - Serving Wire Center
- DTT - Direct - Trunked Transport [1]
- AT - Access Tandem
- EO - End Office
- LS - Local Switching
- CL - Common Line
- EU - End User
- ↙ ↘ - Indicates Rate Elements

[1] DS1 to Voice Grade multiplexing equipment required in the EO when Lineside and Trunkside Access Services are combined on the same facility.

**NOTICE**  
 THE INFORMATION CONTAINED IN THIS DOCUMENT IS SUBJECT TO CHANGE.

**Qwest Corporation**  
**Access Service**  
**Catalog No. 1**

**SECTION 6**  
 Page 7  
 Release 1  
 Effective: 8-1-05

**NORTHERN IDAHO**  
 Issued: 7-1-05

**6. SWITCHED ACCESS SERVICE**

**6.1 GENERAL**

**6.1.2 RATE CATEGORIES (Cont'd)**

**EXAMPLE 3**

**Switched Access Service Ordered with DS1 EF for DTT & TST**

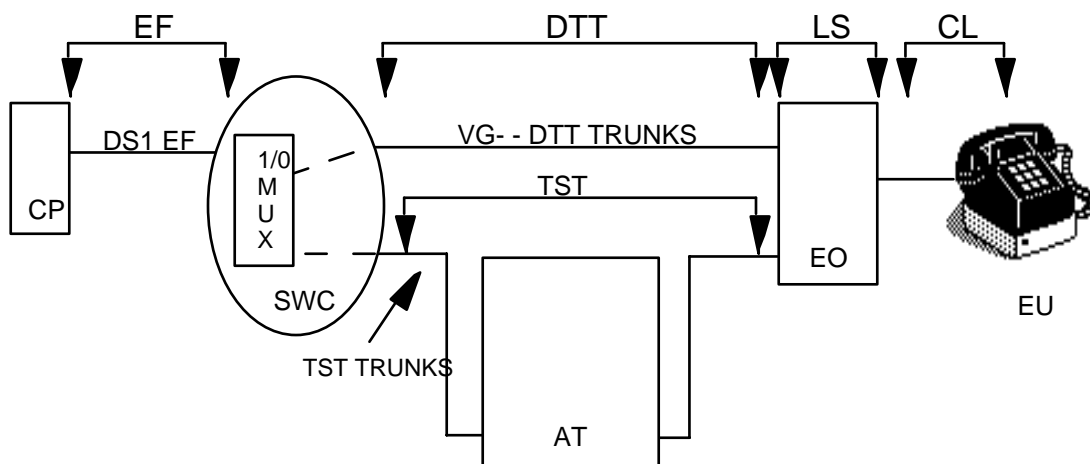

- CP - Customer's Premises
- EF - Entrance Facility[1]
- SWC - Serving Wire Center
- DTT - Direct - Trunked Transport
- TST - Tandem - Switched Transport includes Tandem Switching and Tandem Transmission
- AT - Access Tandem
- EO - End Office
- LS - Local Switching
- CL - Common Line
- EU - End User
- ↙ ↘ - Indicates Rate Elements

[1] DS1 to Voice Grade multiplexing equipment required in the SWC when DTT and TST utilize the same DS1 EF.

**NOTICE**  
 THE INFORMATION CONTAINED IN THIS DOCUMENT IS SUBJECT TO CHANGE.

**Qwest Corporation**  
**Access Service**  
**Catalog No. 1**

SECTION 6  
 Page 8  
 Release 1  
 Effective: 8-1-05

**NORTHERN IDAHO**  
 Issued: 7-1-05

**6. SWITCHED ACCESS SERVICE**

**6.1 GENERAL**  
**6.1.2 RATE CATEGORIES (Cont'd)**

**EXAMPLE 4**

**Switched Access Service Ordered with DS3 EF, Optional 3/1 Multiplexer and TST**

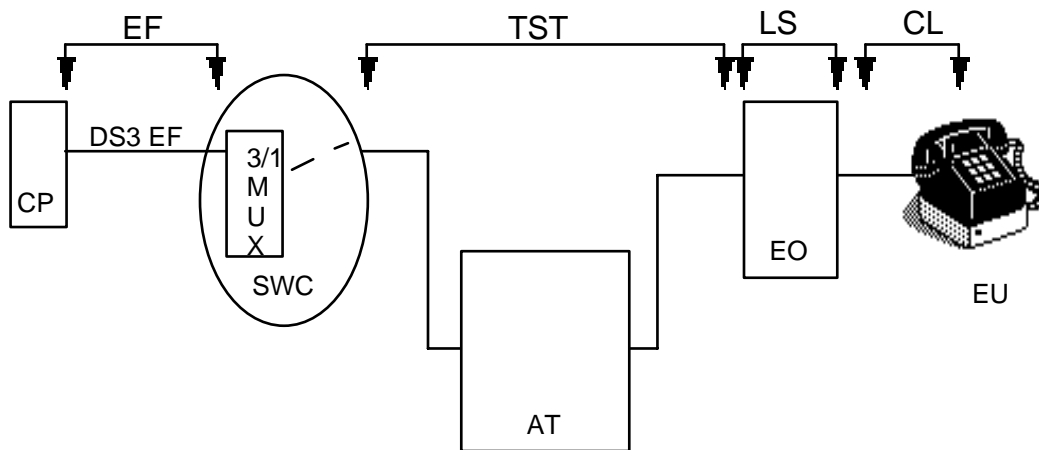

- CP - Customer's Premises
- EF - Entrance Facility[1]
- SWC - Serving Wire Center
- TST - Tandem - Switched Transport includes Tandem Switching and Tandem Transmission
- AT - Access Tandem
- EO - End Office
- LS - Local Switching
- CL - Common Line
- EU - End User
- Indicates Rate Elements

[1] DS3 to DS1 multiplexing equipment is required in the SWC.

**NOTICE**  
 THE INFORMATION CONTAINED IN THIS DOCUMENT IS SUBJECT TO CHANGE.

**Qwest Corporation**  
**Access Service**  
**Catalog No. 1**

**SECTION 6**  
 Page 9  
 Release 1  
 Effective: 8-1-05

**NORTHERN IDAHO**  
 Issued: 7-1-05

**6. SWITCHED ACCESS SERVICE**

**6.1 GENERAL**  
**6.1.2 RATE CATEGORIES (Cont'd)**

**EXAMPLE 5**

**Switched Access Service Ordered with DS3 EF and DS3 DTT Facility**

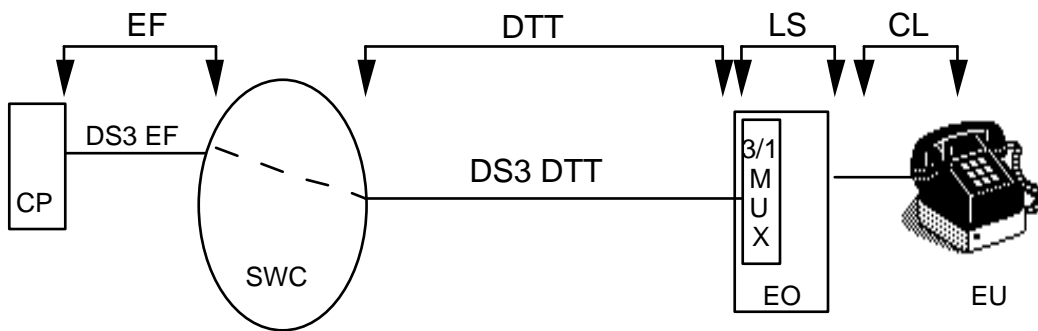

- CP - Customer's Premises
- EF - Entrance Facility
- SWC - Serving Wire Center
- DTT - Direct - Trunked Transport [1,2]
- AT - Access Tandem
- EO - End Office
- LS - Local Switching
- CL - Common Line
- EU - End User
- ↙ ↘ - Indicates Rate Elements

- [1] DS3 to DS1 multiplexing equipment is required in EO. In addition, DS1 to Voice Grade multiplexing equipment is required in the EO when Lineside and Trunkside Access Services are combined on the same DS1 facility.
- [2] When DS3 DTT is provided, only those valid NXX codes served by that EO may be accessed.

**NOTICE**  
 THE INFORMATION CONTAINED IN THIS DOCUMENT IS SUBJECT TO CHANGE.

**Qwest Corporation**  
**Access Service**  
**Catalog No. 1**

**SECTION 6**  
 Page 10  
 Release 1  
 Effective: 8-1-05

**NORTHERN IDAHO**  
 Issued: 7-1-05

**6. SWITCHED ACCESS SERVICE**

**6.1 GENERAL**  
**6.1.2 RATE CATEGORIES (Cont'd)**

**EXAMPLE 6**

**Switched Access Service Ordered with DS3 EF for DTT and TST**

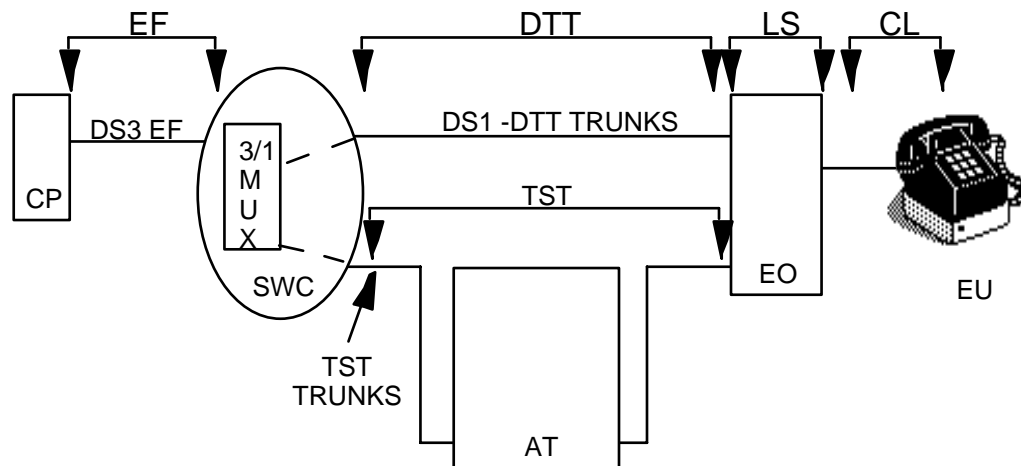

- CP - Customer's Premises
- EF - Entrance Facility[1]
- SWC - Serving Wire Center
- DTT - Direct - Trunked Transport[2]
- TST - Tandem - Switched Transport includes Tandem Switching and Tandem Transmission
- AT - Access Tandem
- EO - End Office
- LS - Local Switching
- CL - Common Line
- EU - End User
- ↙ ↘ - Indicates Rate Elements

[1] DS3 to DS1 multiplexing equipment is required in SWC.

[2] DS1 to Voice Grade multiplexing equipment is required in the EO when Lineside and Trunkside Access Services are combined in the same DS1 facility.

**NOTICE**  
 THE INFORMATION CONTAINED IN THIS DOCUMENT IS SUBJECT TO CHANGE.

**Qwest Corporation**  
**Access Service**  
**Catalog No. 1**

**SECTION 6**  
Page 11  
Release 1  
Effective: 8-1-05

**NORTHERN IDAHO**  
Issued: 7-1-05

**6. SWITCHED ACCESS SERVICE**

**6.1 GENERAL**

**6.1.2 RATE CATEGORIES (Cont'd)**

**EXAMPLE 7**

**Switched Access Service Connected to  
Expanded Interconnection-Collocation (EIC)  
Service at the SWC[1]**

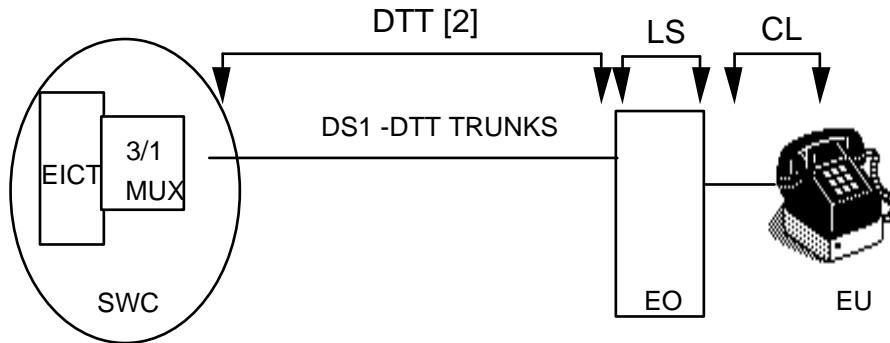

- EICT - DS3 Expanded Interconnection-Collocation Channel Termination
- SWC - Serving Wire Center
- DTT - Direct - Trunked Transport [2]
- EO - End Office
- LS - Local Switching
- CL - Common Line
- EU - End User
- ↙ ↘ - Indicates Switched Access Service Rate Elements

[1] DS3 Entrance Facility is not applicable.

[2] DTT mileage measurement is based on the V&H coordinates of the SWC and the EO wire center building.

**NOTICE**  
**THE INFORMATION CONTAINED IN THIS DOCUMENT IS SUBJECT TO CHANGE.**

**Qwest Corporation**  
**Access Service**  
**Catalog No. 1**

**SECTION 6**  
Page 12  
Release 1  
Effective: 8-1-05

**NORTHERN IDAHO**  
Issued: 7-1-05

**6. SWITCHED ACCESS SERVICE**

**6.1 GENERAL**

**6.1.2 RATE CATEGORIES (Cont'd)**

**EXAMPLE 8**  
**Switched Access Service Connected to EIC**  
**Service in the Same Wire Center**  
**Building as the EO [1]**

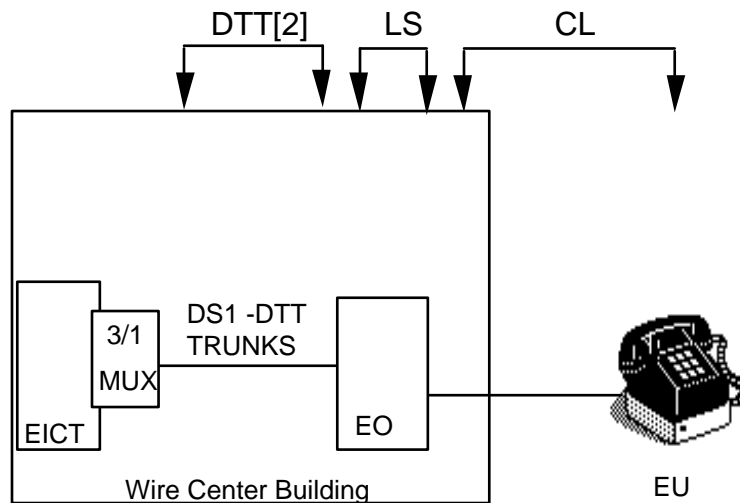

- EICT - DS3 Expanded Interconnection-Collocation Service Channel Termination
- DTT - Direct -Trunked Transport[2]
- EO - End Office
- LS - Local Switching
- CL - Common Line
- EU - End User
-  - Indicates Switched Access Service Rate Elements

[1] DS3 Entrance Facility is not applicable.

[2] DTT mileage measurement is zero when the EO is located in the same wire center building as the EIC Service.

**NOTICE**  
**THE INFORMATION CONTAINED IN THIS DOCUMENT IS SUBJECT TO CHANGE.**

**Qwest Corporation**  
**Access Service**  
**Catalog No. 1**

**SECTION 6**  
 Page 13  
 Release 1  
 Effective: 8-1-05

**NORTHERN IDAHO**  
 Issued: 7-1-05

**6. SWITCHED ACCESS SERVICE**

**6.1 GENERAL**  
**6.1.2 RATE CATEGORIES (Cont'd)**

**EXAMPLE 9**  
**Switched Access Service Connected to EIC**  
**Service in the Same Wire Center**  
**Building as the AT [1]**

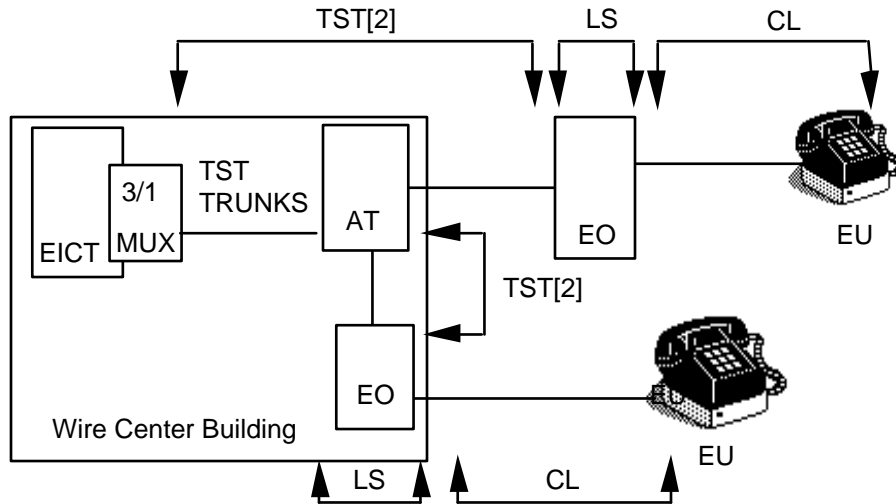

- EICT** - DS3 Expanded Interconnection-Collocation Channel Termination
- TST** -Tandem Switched Transport[2]
- EO** - End Office
- LS** - Local Switching
- CL** - Common Line
- EU** - End User
- ↙ ↘** - Indicates Switched Access Service Rate Elements

[1] DS3 Entrance Facility is not applicable.

[2] Mileage measurement for TST between the EIC Service and the AT and the AT and EO in the same wire center building is a zero mileage band. Mileage measurement is applicable for TST between the AT and subtending EO(s) not located in the same wire center building as the AT.

**NOTICE**  
 THE INFORMATION CONTAINED IN THIS DOCUMENT IS SUBJECT TO CHANGE.

**Qwest Corporation**  
**Access Service**  
**Catalog No. 1**

**SECTION 6**  
Page 14  
Release 1  
Effective: 8-1-05

**NORTHERN IDAHO**  
Issued: 7-1-05

**6. SWITCHED ACCESS SERVICE**

**6.1 GENERAL**

**6.1.2 RATE CATEGORIES (Cont'd)**

A. Switched Transport

1. General Description

The Switched Transport rate category provides the transmission facilities between the customer's premises and the end office switch(es) where the customer's traffic is switched to originate or terminate its communications.

Switched Transport is a two-way voice frequency transmission path composed of an Entrance Facility (EF), Direct-Trunked Transport (DTT) facility, and/or Tandem-Switched Transport (TST) facility which permits the transport of calls in the originating direction (from the end user's end office switch to the customer's premises) and in the terminating direction (from the customer's premises to the end office switch), but not simultaneously. The voice-frequency transmission path may be comprised of any form or configuration of plant capable of and typically used in the telecommunications industry for the transmission of voice and associated telephone signals within the frequency bandwidth of approximately 300 to 3000 Hz.

When a Switched Access Service connects to EI Service as set forth in Section 21, following, the Switched Access Service designated SWC and customer point of interconnection are defined as set forth in 6.1.1, preceding.

The Company will work cooperatively with the customer in determining (1) the EF, (2) whether the service is to be directly routed or routed through an access tandem switch, (3) the directionality of the service and (4) the hubbing arrangements. Switched Transport optional features are provided as set forth in 4., following.

Switched Transport is provided at the rates and charges set forth in 6.8, following. The application of these rates with respect to the different types of service is as set forth in 6.7.1, following. DTT and TST will be assessed rates based on the actual transport provided. Tandem switched traffic will be assessed TST rates and direct routed traffic will be assessed DTT rates except as set forth in 6.7.1, following.

**NOTICE**  
**THE INFORMATION CONTAINED IN THIS DOCUMENT IS SUBJECT TO CHANGE.**

**Qwest Corporation**  
**Access Service**  
**Catalog No. 1**

**SECTION 6**  
Page 15  
Release 1  
Effective: 8-1-05

**NORTHERN IDAHO**  
Issued: 7-1-05

Effective: 8-1-05

---

**6. SWITCHED ACCESS SERVICE**

**6.1 GENERAL**

**6.1.2 RATE CATEGORIES**

A.1. (Cont'd)

Switched Access Service is ordered under the access order provisions as set forth in Section 5, preceding. Design and traffic routing of Switched Access Service is described in 6.5.2, following.

Switched Transport is composed of an Entrance Facility (EF) rate category, as described in a., following, a Direct-Trunked Transport (DTT) rate category, as described in b., following, and a Tandem-Switched Transport (TST) rate category, as described in c., following.

a. Switched Transport EF Rate Category

An EF provides the communication path between a customer's premises and the Company SWC of that premises for the sole use of the customer. The EF rate category is composed of a Voice Grade rate, a DS1 rate or a DS3 rate. An EF is provided even if the customer's premises and the SWC are located in the same building. The types of facilities available for Entrance Facilities are described in 2., following.

The EF rate category does not apply when Switched Access Service connects to EI Service as set forth in Section 21, following.

**NOTICE**  
**THE INFORMATION CONTAINED IN THIS DOCUMENT IS SUBJECT TO CHANGE.**

**Qwest Corporation**  
**Access Service**  
**Catalog No. 1**

**SECTION 6**  
Page 16  
Release 1  
Effective: 8-1-05

**NORTHERN IDAHO**  
Issued: 7-1-05

---

**6. SWITCHED ACCESS SERVICE**

**6.1 GENERAL**

**6.1.2 RATE CATEGORIES**

A.1. (Cont'd)

b. Switched Transport DTT Rate Category

DTT provides the transmission path without utilizing tandem switching functions on circuits dedicated to the use of a single customer between:

- The customer's SWC and an end office, or;
- The customer's SWC and an access tandem, or;
- The customer's SWC and a Company Hub where multiplexing functions are performed, or;
- A Company Hub and an end office, or;
- A Company Hub and an access tandem.

When a customer orders DTT to an access tandem, all Switched Transport to that same access tandem must be DTT for the same Feature Group type. A Feature Group ordered with DTT cannot be combined on the same transport facility (i.e., DS3 or DS1) with a Feature Group ordered with TST. Different Feature Groups may be combined on the same transport facility if the rating option is the same.

The DTT rate category is composed of a monthly fixed rate and a monthly per-mile rate based on the facility provided, (i.e., Voice Grade, DS1 or DS3). The fixed rate provides the circuit equipment at the ends of the transmission paths. The per-mile rate provides the transmission facilities, including intermediate transmission circuit equipment, between the end points of the circuit. The DTT rate is the sum of the fixed rate and the per-mile rate. For purposes of determining the per-mile rate, mileage will be measured as airline mileage using the V & H coordinates method. Mileage measurement rules are set forth in 6.7.10, following. The types of facilities available for DTT are described in 2., following.

**NOTICE**  
**THE INFORMATION CONTAINED IN THIS DOCUMENT IS SUBJECT TO CHANGE.**

**Qwest Corporation**  
**Access Service**  
**Catalog No. 1**

**SECTION 6**  
Page 17  
Release 1  
Effective: 8-1-05

**NORTHERN IDAHO**  
Issued: 7-1-05

**6. SWITCHED ACCESS SERVICE**

**6.1 GENERAL**

**6.1.2 RATE CATEGORIES**

A.1. (Cont'd)

c. Switched Transport TST Rate Category

TST provides the transmission facilities between the SWC of the customer's premises and the end offices subtending the access tandem or between an access tandem and end offices subtending that tandem utilizing tandem switching functions. TST is not available from or to a Company Hub. TST consists of circuits dedicated to the use of a single customer from the SWC of the customer's premises to the access tandem and circuits used in common by multiple customers from the access tandem to an end office. For TST, the Company will determine the type of facilities to the end office(s) based on the customer's order for service on a per-trunk basis or on a BHMC basis.

When a customer orders TST from the SWC, through a specific access tandem to subtending end offices, all Switched Transport must be ordered as TST between the SWC and that access tandem for the same Feature Group type. A Feature Group ordered with TST cannot be combined on the same transport facility (i.e., DS3 or DS1) with a Feature Group ordered with DTT. Different Feature Groups may be combined on the same transport facility if the rating option is the same.

The TST rate category is composed of a Tandem Transmission fixed MOU rate, Tandem Transmission per-mile/per-MOU rate and a Tandem Switching MOU rate. The fixed rate provides the circuit equipment at the end of the interoffice transmission paths. The per-mile rate provides the transmission facilities, including intermediate transmission circuit equipment between the end points of the interoffice circuit. For purposes of determining the per-mile rate, mileage will be measured as airline mileage using the V & H coordinates method. Mileage measurement rules are set forth in 6.7.10, following. The Tandem Switching rate provides for tandem switching facilities. The TST rate is the sum of the fixed rate, the per-mile rate and the Tandem Switching MOU rate.

**NOTICE**  
**THE INFORMATION CONTAINED IN THIS DOCUMENT IS SUBJECT TO CHANGE.**

**Qwest Corporation**  
**Access Service**  
**Catalog No. 1**

**SECTION 6**  
Page 18  
Release 1  
Effective: 8-1-05

**NORTHERN IDAHO**  
Issued: 7-1-05

**6. SWITCHED ACCESS SERVICE**

**6.1 GENERAL**

**6.1.2 RATE CATEGORIES**

A. Switched Transport (Cont'd)

2. Switched Transport Facilities

Customers requesting Lineside or Trunkside Switched Access Service shall specify the type of Entrance Facility (Voice Grade, DS1 or DS3) between the customer's premises and the SWC. The customer shall also specify if DTT or TST is desired. If TST is requested, the Company will determine the type of facilities to the subtending end offices. TST is not available for Lineside Switched Access Service. If DTT is requested, the customer shall specify the type of DTT facility (Voice Grade, DS1 or DS3) to be utilized.

There are three types of facilities, Voice Grade, DS1 or DS3, available to the customer for Entrance Facilities and DTT facilities for Lineside or Trunkside Switched Access Service. Following is a brief description of each type of facility. Each type has its own characteristics and is available with multiplexing options as set forth in 4., following.

a. Voice Grade Facility

Voice Grade facilities are available for Entrance Facilities and for DTT facilities. A Voice Grade facility is an electrical communications path which provides voice-frequency transmission in the nominal frequency range of 300 to 3000 Hz and may be terminated two-wire or four-wire. Compatible Interface Groups are described in 3., following.

b. DS1 Facility

DS1 facilities are available for Entrance Facilities and for DTT facilities. A DS1 facility is capable of transmitting electrical signals at a nominal 1.544 Mbps, with the capability to channelize up to 24 voice-frequency transmission paths. Compatible Interface Groups are described in 3., following.

c. DS3 Facility

DS3 facilities are available for Entrance Facilities and DTT facilities. A DS3 facility is capable of transmitting electrical signals at a nominal 44.736 Mbps, with the capability to channelize up to 672 voice-frequency transmission paths. Compatible Interface Groups are described in 3., following.

**NOTICE**  
**THE INFORMATION CONTAINED IN THIS DOCUMENT IS SUBJECT TO CHANGE.**

**Qwest Corporation**  
**Access Service**  
**Catalog No. 1**

**SECTION 6**  
Page 19  
Release 1  
Effective: 8-1-05

**NORTHERN IDAHO**  
Issued: 7-1-05

---

**6. SWITCHED ACCESS SERVICE**

**6.1 GENERAL**

**6.1.2 RATE CATEGORIES**

A.2. (Cont'd)

d. Hubbing

Hubbing arrangements can be ordered from Section 7 of the Interstate Access Service Tariff F.C.C. No. 1 for transport of both PLTS and Switched Access Service. Hubbing arrangements out of Section 6. are to be utilized for transport of Switched Access Service only.

A Hub is a Company designated wire center at which multiplexing functions are performed. Hubbing allows the customer to terminate a Switched Transport facility to a Hub so that the facility can be de-multiplexed to a lower capacity and the lower capacity channels are then routed to different switches or locations. Multiplexing functions for an EF can be provided at the SWC. For DTT facilities, hubbing is available at wire centers other than the SWC. Hubbing is only available on the interoffice link between the SWC and the access tandem when the customer has requested DTT from the SWC to the access tandem and TST from the access tandem to end offices subtending that tandem.

Multiplexing functions are described in 4., following. Hub locations and the types of multiplexing available at each location for DS1 facilities are specified in the NECA Tariff F.C.C. No. 4. For DS3 facilities, the Company will work cooperatively with the customer to provide the desired hubbing arrangements in all wire centers.

**NOTICE**  
**THE INFORMATION CONTAINED IN THIS DOCUMENT IS SUBJECT TO CHANGE.**

**Qwest Corporation**  
**Access Service**  
**Catalog No. 1**

**SECTION 6**  
Page 20  
Release 1  
Effective: 8-1-05

**NORTHERN IDAHO**  
Issued: 7-1-05

Effective: 8-1-05

**6. SWITCHED ACCESS SERVICE**

**6.1 GENERAL**

**6.1.2 RATE CATEGORIES**

A. Switched Transport (Cont'd)

3. Interface Groups

Four Interface Groups are provided for terminating Switched Transport at the customer's premises. Each Interface Group provides a specified premises interface (e.g., two-wire, four-wire, DS1, etc.). Where transmission facilities permit, the individual transmission path between the customer's premises and the first point of switching may, at the option of the customer, be provided with optional features as set forth in 4., following.

As a result of the customer's access order and the type of Company transport facilities serving the customer's premises, the need for signaling conversions or two-wire to four-wire conversions, or the need to terminate digital or high-frequency facilities in channel bank equipment may require that Company equipment be placed at the customer's premises. For example, if a voice-frequency interface is ordered by the customer and the Company facilities serving the customer's premises are digital, then Company channel bank equipment must be placed at the customer's premises in order to provide the voice-frequency interface ordered by the customer.

Interface Group Transmission Specifications and Data Transmission Parameters are delineated in Technical Reference PUB GR-334-CORE.

Only certain Network Channel Interface (NCI) codes are available at the customer's premises. The NCI codes associated with the Interface Groups may vary among different types of service based on the technical requirements. The various premises interfaces which are available with the Interface Groups, and the types of service with which they may be used, are set forth in the Technical Reference PUB GR-334-CORE and associated addenda.

**NOTICE**  
**THE INFORMATION CONTAINED IN THIS DOCUMENT IS SUBJECT TO CHANGE.**

**Qwest Corporation**  
**Access Service**  
**Catalog No. 1**

**SECTION 6**  
Page 21  
Release 1  
Effective: 8-1-05

1  
**NORTHERN IDAHO**  
Issued: 7-1-05

**6. SWITCHED ACCESS SERVICE**

**6.1 GENERAL**  
**6.1.2 RATE CATEGORIES**  
A.3. (Cont'd)

Based upon the Interface Group chosen by the customer, multiplexing arrangements may be required. Multiplexing arrangements are described in 4., following.

When Switched Access Services are ordered in conjunction with Private Line Transport DS3 Service which is provisioned with an optical interface, the common interface will be provisioned under the rules and regulations for Shared Use between Private Line Transport and Switched Access Services referenced in 2.7, preceding. The rate for the optical interface set forth in 6.8, following, is for the billing of Shared Use only. Switched Access Services rates and charges as set forth in 6.8, following, will apply for each channel of the Shared Use facility that is used to provide Switched Access Service. Technical specifications are delineated in Qwest Corporation Technical Publication PUB 77324.

When Interface Groups 1, 2, 6 or 9 are associated with FGD Service with SS7 Out of Band Signaling, no signaling will be done via the message channel.

a. Interface Group 1

Interface Group 1, except as set forth in the following, provides two-wire voice frequency transmission at the customer's premises.

Interface Group 1 is not provided in association with Trunkside Access when the first point of switching is an access tandem. In addition, Interface Group 1 is not provided in association with Trunkside Access when the first point of switching provides only four-wire terminations.

**NOTICE**  
**THE INFORMATION CONTAINED IN THIS DOCUMENT IS SUBJECT TO CHANGE.**

**Qwest Corporation**  
**Access Service**  
**Catalog No. 1**

**SECTION 6**  
Page 22  
Release 1  
Effective: 8-1-05

**NORTHERN IDAHO**  
Issued: 7-1-05

---

**6. SWITCHED ACCESS SERVICE**

**6.1 GENERAL**

**6.1.2 RATE CATEGORIES**

A.3. (Cont'd)

b. Interface Group 2

Interface Group 2 provides four-wire voice-frequency transmission at the customer's premises.

c. Interface Group 6

Interface Group 6 provides DS1-level digital transmission at the customer's premises. The interface may be provided with Clear Channel Capability.

d. Interface Group 9

Interface Group 9 provides DS3-level digital transmission at the customer's premises.

4. Optional Features

Where transmission facilities permit, the Company will, at the option of the customer, provide the following Switched Transport optional features as set forth in 6.8, following.

a. POT Supervisory Signaling Arrangements

Where the transmission parameters permit, and where signaling conversion is required by the customer to meet its signaling capability, the customer may order a POT supervisory signaling arrangement for each transmission path. Available supervisory signaling arrangements for lineside and trunkside terminations and the technical specifications are delineated in Technical Reference PUB GR-334-CORE.

**NOTICE**  
**THE INFORMATION CONTAINED IN THIS DOCUMENT IS SUBJECT TO CHANGE.**

**Qwest Corporation**  
**Access Service**  
**Catalog No. 1**

**SECTION 6**  
Page 23  
Release 1  
Effective: 8-1-05

**NORTHERN IDAHO**  
Issued: 7-1-05

---

**6. SWITCHED ACCESS SERVICE**

**6.1 GENERAL**

**6.1.2 RATE CATEGORIES**

A.4. (Cont'd)

b. Customer Specified Entry Switch Receive Level

This feature allows the customer to specify the receive transmission level at the first point of switching. The range of transmission levels which may be specified is described in Technical Reference PUB GR-334-CORE. This feature is available with Interface Groups 2, 6 and 9 for Feature Groups A and B.

c. Customer Specification of Local Transport Termination

This option allows the customer to specify, for Feature Group B routed directly to an end office or an access tandem, a four-wire termination of the Switched Transport at the entry switch in lieu of a Company selected two-wire termination. This option is available only when the Feature Group B arrangement is provided with Transmission Type B1 performance.

d. Multiple POTs Tandem Sectorization (MPTS)

Multiple POTs Tandem Sectorization is an optional feature designed to meet the traffic routing requirements of customers whose Feature Group C and D originating Switched Access Services are routed through an access tandem to multiple customer points of termination (POTs).

MPTS is available in connection with originating Feature Group C and D Services. MPTS allows originating Feature Group C and D traffic to be directed via an access tandem to a specific POT designated by the customer. MPTS permits customers with multiple customer POTs within a tandem serving area to balance the call volume within their respective networks. MPTS may be used in conjunction with the Common Switching Optional Feature Service Class Routing (e.g., 8XX, 900, MTS or Operator), as specified in 6.3.1, following.

**NOTICE**  
**THE INFORMATION CONTAINED IN THIS DOCUMENT IS SUBJECT TO CHANGE.**

**Qwest Corporation**  
**Access Service**  
**Catalog No. 1**

**SECTION 6**  
Page 24  
Release 1  
Effective: 8-1-05

**NORTHERN IDAHO**  
Issued: 7-1-05

---

**6. SWITCHED ACCESS SERVICE**

**6.1 GENERAL**

**6.1.2 RATE CATEGORIES**

A.4.d. (Cont'd)

End offices subtending the tandem serving area will be divided into sectors, referred to as Feature Group C and D Tandem Sectors, which will be defined by the Company. Each Tandem Sector must be treated as a unit and cannot be subdivided. Tandem Sectors are standard for all customers who purchase MPTS. MPTS must be ordered to every sector of an access tandem. A customer with multiple customer premises POTs within the tandem serving area can designate to which POT the traffic from a specific Tandem Sector will be routed. For example, a customer with multiple customer POTs can request that all originating calls from a Tandem Sector be directed to a single POT. In addition, originating traffic from a different Tandem Sector could be routed to the same POT or a different POT as designated by the customer.

Tandem routed traffic can be delivered to a minimum number of two POTs and a maximum number of POTs that is less than or equal to the number of Tandem Sectors defined for a particular Tandem. The end offices associated with the Tandem Sectors can be found in the Qwest Corporation Tandem Sectorization Guide.

The Company shall not be required to route traffic from a Tandem Sector to more than one POT unless the customer has the optional feature, Service Class Routing as described in 6.3.1.L., following, in addition to MPTS. Tandem routed traffic with Service Class Routing can be delivered by traffic type to a minimum number of one POT and a maximum number of POTs that is less than or equal to the number of Tandem Sectors defined for a particular tandem. A maximum number of four (4) trunk groups with mixed traffic types in accordance with the Service Class Routing specifications is allowed for each designated Tandem Sector. Each traffic type (e.g., 8XX, 900, MTS or Operator) within a Tandem Sector can be designated to the same POT or different POTs. A customer with multiple POTs must direct all originating calls from a Tandem Sector to a single POT by traffic type.

**NOTICE**  
**THE INFORMATION CONTAINED IN THIS DOCUMENT IS SUBJECT TO CHANGE.**

**Qwest Corporation**  
**Access Service**  
**Catalog No. 1**

**SECTION 6**  
Page 25  
Release 1  
Effective: 8-1-05

**NORTHERN IDAHO**  
Issued: 7-1-05

---

**6. SWITCHED ACCESS SERVICE**

**6.1 GENERAL**

**6.1.2 RATE CATEGORIES**

A.4.d. (Cont'd)

MPTS in conjunction with Service Class Routing - A customer may designate one to four POTs per traffic type. For example, when MPTS is ordered for a specific tandem, it is possible to route all of a particular traffic type (e.g., 8XX, 900, MTS or Operator) to only one POT subtending that tandem, as long as other traffic type(s) comply to the stated MPTS guidelines of directing traffic to multiple POTs within a tandem serving area as referred to in 6.3.1.L., following.

MPTS in conjunction with Alternate Traffic Routing - If a customer wants a direct trunk group from an end office to alternate route to a tandem routed trunk group subtending the same end office, the customer can designate the direct routed traffic sent to any POT, but the tandem routed trunk group must be routed to the customer designated POT that is specified for the Tandem Sector as referred to in 6.3.1.M., following.

e. Multiplexing

Multiplexing provides the capability of converting the capacity or bandwidth of a facility from a higher level to a lower level or from a lower level to a higher level. Multiplexing functions for an EF are available at a SWC. For DTT facilities, multiplexing is available at a Company Hub, end office or access tandem. Multiplexing arrangements are associated with the facility with the higher capacity or bandwidth (e.g., a DS1 to Voice Grade multiplexing arrangement is associated with the facility using a DS1 connection). Section 6 multiplexing arrangements may be connected to an EILT as set forth in Section 21, following. Multiplexing arrangements are described following.

(1) DS1 to Voice Grade

DS1 to Voice Grade multiplexing is an arrangement that provides a Company multiplexer which converts a DS1 channel to twenty-four Voice Grade channels utilizing time division multiplexing. For example, the customer has the option of ordering a DS1 to Voice Grade multiplexer for a DS1 Entrance Facility at the SWC when Voice Grade DTT is requested to an end office.

**NOTICE**  
**THE INFORMATION CONTAINED IN THIS DOCUMENT IS SUBJECT TO CHANGE.**

**Qwest Corporation**  
**Access Service**  
**Catalog No. 1**

**SECTION 6**  
Page 26  
Release 1  
Effective: 8-1-05

**NORTHERN IDAHO**  
Issued: 7-1-05

---

**6. SWITCHED ACCESS SERVICE**

**6.1 GENERAL**

**6.1.2 RATE CATEGORIES**

A.4.e. (Cont'd)

(2) DS3 to DS1

DS3 to DS1 multiplexing is an arrangement which converts a DS3 channel to twenty-eight DS1 channels utilizing time division multiplexing. The twenty-eight channels may be further multiplexed utilizing DS1 to Voice Grade multiplexing equipment.

Multiplexing equipment is provided at no charge by the Company (at a location determined by the Company as part of its overall network design) when the following conditions exist:

- a DS1 Entrance Facility is requested by the customer in conjunction with TST from a SWC to end offices subtending an access tandem, or
- a DTT at a DS1 level is requested from a SWC to an access tandem in conjunction with TST from an access tandem to subtending end offices, or
- a DS1 DTT facility terminates in an end office except when Lineside and Trunkside Access are combined on the same facility.

If the customer chooses to order multiplexing equipment at a location other than the location determined by the Company, the customer will be assessed multiplexing rates as set forth in 6.8, following.

**NOTICE**  
**THE INFORMATION CONTAINED IN THIS DOCUMENT IS SUBJECT TO CHANGE.**

**Qwest Corporation**  
**Access Service**  
**Catalog No. 1**

**SECTION 6**  
Page 27  
Release 1  
Effective: 8-1-05

**NORTHERN IDAHO**  
Issued: 7-1-05

---

**6. SWITCHED ACCESS SERVICE**

**6.1 GENERAL**

**6.1.2 RATE CATEGORIES**

A.4.e. (Cont'd)

Multiplexing arrangements are required and the customer will be assessed multiplexing rates as set forth in 6.8, following, when the following conditions exist:

- a DS3 EF facility is requested, or
- a DS3 EF connects to a DS1 DTT facility and/or TST, or
- a DS1 EF connects to a Voice Grade DTT facility, or
- a DS1 EF connects to multiple tandems, via TST, or
- a higher capacity DTT facility connects to a lower capacity DTT facility at a Company Hub, or
- a DS1 DTT facility transports a combination of Lineside and Trunkside Access to an end office on the same facility, or
- Shared Use facilities are requested.

**NOTICE**  
**THE INFORMATION CONTAINED IN THIS DOCUMENT IS SUBJECT TO CHANGE.**

**Qwest Corporation**  
**Access Service**  
**Catalog No. 1**

**SECTION 6**  
Page 28  
Release 1  
Effective: 8-1-05

**NORTHERN IDAHO**  
Issued: 7-1-05

---

**6. SWITCHED ACCESS SERVICE**

**6.1 GENERAL**

**6.1.2 RATE CATEGORIES**

A.4. (Cont'd)

f. Tandem Signaling Information Option

Tandem Signaling Information (TSI) is an option of the DTT facility. TSI provides the capability of transporting in-band (MF) or out of band (SS7) signaling information over EF and DTT facilities for the purpose of providing tandem signaling information between a customer-provided tandem switch premises and a Company equal access end office. In-band TSI provides the Carrier Identification Code (CIC) which identifies the interexchange carrier and the 0ZZ code which identifies the interexchange carrier trunk to which traffic should be directly routed. For out of band TSI, the CIC and 0ZZ code equivalent is provided in the Transit Network Selection (TNS) and the Network Identification Code (NIC) of the SS7 parameter initial address message. When a customer requires TSI to be provided out of band, the customer must order CCSAC Service using the Common Channel Signaling Network (CCSN) as set forth in Section 15, following.

When TSI is ordered on a DTT facility only FGD Service may be transported over the facility.

**NOTICE**  
**THE INFORMATION CONTAINED IN THIS DOCUMENT IS SUBJECT TO CHANGE.**

**Qwest Corporation**  
**Access Service**  
**Catalog No. 1**

**SECTION 6**  
Page 29  
Release 1  
Effective: 8-1-05

**NORTHERN IDAHO**  
Issued: 7-1-05

---

**6. SWITCHED ACCESS SERVICE**

**6.1 GENERAL**

**6.1.2 RATE CATEGORIES (Cont'd)**

B. Local Switching

The Local Switching rate category provides the local end office switching, end user line termination and intercept functions necessary to complete the transmission of Switched Access communications to and from the end users served by the local end office. The Local Switching rate category includes the Local Switching rate element.

The Local Switching rate element is divided into two distinct categories, i.e., LS1 and LS2. The first category, LS1, provides local dial switching for Feature Groups A and B. The second category, LS2, provides local dial switching for Feature Groups C and D, and for Feature Groups A and B originating or terminating access minutes when the service is provided to customers who furnish MTS/WATS.

Rates for LS1 and LS2 are set forth in 6.8, following. The application of these rates with respect to the different types of service is as set forth in 6.7.1, following.

1. Local End Office Switching Functions

a. Common Switching

Common Switching provides the local end office switching functions associated with the various access (i.e., Feature Group) switching arrangements. The Common Switching arrangements provided for the various types of service arrangements are described in 6.2, following.

Included as part of Common Switching are various optional features which the customer can order to meet its specific communications requirements. These optional features are described in 6.3.1, following.

**NOTICE**  
**THE INFORMATION CONTAINED IN THIS DOCUMENT IS SUBJECT TO CHANGE.**

**Qwest Corporation**  
**Access Service**  
**Catalog No. 1**

**SECTION 6**  
Page 30  
Release 1  
Effective: 8-1-05

**NORTHERN IDAHO**  
Issued: 7-1-05

---

**6. SWITCHED ACCESS SERVICE**

**6.1 GENERAL**

**6.1.2 RATE CATEGORIES**

B.1. (Cont'd)

b. Transport Termination

Transport Termination provides for the lineside or trunkside arrangements which terminate the Switched Transport facilities. Included as part of Transport Termination are various optional termination arrangements. These optional terminating arrangements are described in 6.3.2, following.

The number of Transport Terminations provided for the lineside or trunkside arrangement will be determined by the Company as set forth in 6.5.8, following.

2. Line Termination Functions

Common Line Terminations and WATS Access Line Terminations are provided for end user lines terminating in local end offices.

The WATS Access Line Terminations are differentiated by lineside vs trunkside terminations. In addition, there are various types of originating and terminating lineside terminations depending on the type of signaling associated with the WATS Access Line. Lineside terminations are available with either dial pulse or dual tone multifrequency address signaling.

3. Intercept Function

The Intercept function provides for the termination of a call at a Company Intercept operator or recording. The operator or recording tells a caller why a call, as dialed, could not be completed, and if possible, provides the correct number.

The number of transmission paths will be determined as set forth in 6.5.7, following.

**NOTICE**  
**THE INFORMATION CONTAINED IN THIS DOCUMENT IS SUBJECT TO CHANGE.**

**Qwest Corporation**  
**Access Service**  
**Catalog No. 1**

**SECTION 6**  
Page 31  
Release 1  
Effective: 8-1-05

**NORTHERN IDAHO**  
Issued: 7-1-05

---

**6. SWITCHED ACCESS SERVICE**

**6.1 GENERAL (Cont'd)**

**6.1.3 FACILITIES PROTECTION - SPECIAL FACILITIES ROUTING**

Any customer may request that the facilities used to provide Switched Access Service be specially routed. The regulations, rates and charges for Facilities Protection - Special Facilities Routing (i.e., Avoidance, Diversity, Cable-Only and Hot Standby Protection) are set forth in Section 4 of the Private Line Transport Catalog.

**6.1.4 DESIGN LAYOUT REPORT**

The Company will provide to the customer the makeup of the facilities and services provided from the customer's premises to the first point of switching or from the customer's point of interconnection to the first point of switching when Switched Access Service connects to EI Service, as set forth in Section 21, following. This information will be provided in the form of a Design Layout Report. The Design Layout Report will be provided to the customer at no charge, and will be reissued or updated whenever these facilities are materially changed.

**NOTICE**  
**THE INFORMATION CONTAINED IN THIS DOCUMENT IS SUBJECT TO CHANGE.**

**Qwest Corporation**  
**Access Service**  
**Catalog No. 1**

**SECTION 6**  
Page 32  
Release 1  
Effective: 8-1-05

**NORTHERN IDAHO**  
Issued: 7-1-05

---

**6. SWITCHED ACCESS SERVICE**

**6.1 GENERAL (Cont'd)**

**6.1.5 ACCEPTANCE TESTING**

At no additional charge, the Company will, at the customer's request, cooperatively test, at the time of installation, the following parameters: loss, C-notched noise, C-message noise, 3-tone slope, d.c. continuity and operational signaling. When the Switched Transport is provided with Interface Groups 2, 6 and 9, as available, and the Transport Termination is two-wire (i.e., there is a four-wire to two-wire conversion in Switched Transport), balance parameters (equal level echo path loss) may also be tested. When the Switched Transport is provided with Interface Group 6 or 9, the Company will, at the customer's request, mutually negotiate, at the time of installation, the use of the customer's 108 type test line capabilities to conduct digital testing on 56 kbps, 64 kbps and 64 kbps Clear Channel service.

**6.1.6 ORDERING OPTIONS AND CONDITIONS**

Switched Access Service is ordered under the Access Order provisions set forth in Section 5, preceding. Also, included in that section are other charges which may be associated with ordering Switched Access Service (e.g., Service Date Change Charges, Cancellation Charges, etc.).

**NOTICE**  
**THE INFORMATION CONTAINED IN THIS DOCUMENT IS SUBJECT TO CHANGE.**

**Qwest Corporation**  
**Access Service**  
**Catalog No. 1**

**SECTION 6**  
Page 33  
Release 1  
Effective: 8-1-05

**NORTHERN IDAHO**  
Issued: 7-1-05

**6. SWITCHED ACCESS SERVICE**

**6.2 PROVISION AND DESCRIPTION OF SWITCHED ACCESS SERVICE**

- A. Switched Access Service is provided in different serving arrangements. The provision of each type of Switched Access Service requires Switched Transport facilities (Entrance Facilities, DTT Facilities and/or TST Facilities), multiplexing equipment and the appropriate Local Switching functions.
- B. Transmission Types, (i.e., A1, B, B1 and C) have been identified for the provision of Switched Access Service. The Transmission Types are dependent on the Interface Group and the routing of the service, i.e., whether the service is routed directly to the end office or via an access tandem. The standard parameter limits for the Transmission Types are set forth in Technical Reference PUB GR-334-Core and associated addenda.
- C. Switched Access Services are arranged for either originating, terminating or two-way calling, based on the customer end office switching capacity ordered. Originating calling permits the delivery of calls from telephone exchange service locations to the customer's premises. Terminating calling permits the delivery of calls from the customer's premises to the telephone exchange service locations. Two-way calling permits the delivery of calls in both directions, but not simultaneously. The Company will determine the type of calling to be provided unless the customer requests that a different type of directional calling is to be provided. In such cases, the Company will work cooperatively with the customer to determine the directionality.
- D. There are various optional features available with Switched Access Service. These additional features are provided as Switched Transport, Common Switching, Transport Termination or Line Termination (i.e., WATS Access Line Termination).
- E. Following are detailed descriptions of each of the available Switched Access Services. Each service is described in terms of its specific physical characteristics and calling patterns, the transport provisioning, the transmission specifications with which it is provided, the optional features available for use with it and the standard testing capabilities.
- F. The Common Switching and Transport Termination optional features, which are described in 6.3, following, unless specifically stated otherwise, are available at all Company end office switches.

**NOTICE**  
**THE INFORMATION CONTAINED IN THIS DOCUMENT IS SUBJECT TO CHANGE.**

**Qwest Corporation**  
**Access Service**  
**Catalog No. 1**

**SECTION 6**  
Page 34  
Release 1  
Effective: 8-1-05

.2  
**NORTHERN IDAHO**  
Issued: 7-1-05

**6. SWITCHED ACCESS SERVICE**

**6.2 PROVISION AND DESCRIPTION OF SWITCHED ACCESS SERVICE (Cont'd)**

**6.2.1 FEATURE GROUP A (FGA)**

A. Description

1. FGA Access provides lineside access to Company end office switches for the customer's use in originating communications from and terminating communications to an Interexchange Carrier's intrastate service or a customer-provided intrastate communications capability. The customer must specify the Interexchange Carrier to which the FGA Service is connected or, in the alternative, specify the means by which the FGA Access communication is transported within the state.
2. FGA is provided in connection with Company electronic and electromechanical end offices. FGA may be transported via a DS3, DS1 or Voice Grade Entrance Facility and via a DS3, DS1 or Voice Grade DTT facility. When the customer orders FGA and Trunkside Access to be transported via the same DTT facility, DS1 to Voice Grade multiplexing equipment is always required at the end office at the rates and charges set forth in 6.8, following. When the customer does not combine FGA and Trunkside Access on the same facility, the Company will provide DS1 to Voice Grade multiplexing equipment at no charge. At the option of the customer, FGA is provided on a single or multiple line group basis and is arranged for originating calling only, terminating calling only, or two-way calling.
3. FGA provides a lineside termination at the first point of switching. The Technical Specifications for these terminations are provided in Technical Reference PUB GR-334-CORE and associated addenda.
4. The Company shall select the first point of switching, within the selected LATA, at which the lineside termination is to be provided unless the customer requests a different first point of switching and Company facilities and measurement capabilities, where necessary, are available to accommodate such a request.
5. A seven digit local telephone number assigned by the Company is provided for access to FGA switching in the originating direction. The seven digit local telephone number will be associated with the selected end office switch and is of the form NXX-XXXX.
6. If the customer requests a specific seven digit telephone number that is not currently assigned, and the Company can, with reasonable effort, comply with that request, the requested number will be assigned to the customer.

**NOTICE**  
**THE INFORMATION CONTAINED IN THIS DOCUMENT IS SUBJECT TO CHANGE.**

**Qwest Corporation**  
**Access Service**  
**Catalog No. 1**

**SECTION 6**  
Page 35  
Release 1  
Effective: 8-1-05

**NORTHERN IDAHO**  
Issued: 7-1-05

**6. SWITCHED ACCESS SERVICE**

**6.2 PROVISION AND DESCRIPTION OF SWITCHED ACCESS SERVICE**

**6.2.1 FEATURE GROUP A (FGA)**

A. Description (Cont'd)

7. FX/ONAL FGA switching, when used in the terminating direction, may be used to access valid NXX codes within the same local calling area in which the first point of switching is located. MTS/WATS-type FGA switching in the terminating direction may be used to access valid NXX codes in the LATA. In addition, both FX/ONAL FGA and MTS/WATS-type FGA, when used in the terminating direction, may be used to access local operator service (0- and 0+), emergency reporting service (911 where available), exchange telephone repair (611 where available), community information services of an information service provider, and other customers' services (by dialing the appropriate digits). Charges for FGA terminating calls requiring operator assistance or calls to 611 or 911 will only apply where sufficient call details are available. Additional non-access charges will be billed on a separate account for:
  - a. an operator surcharge for local operator assistance (0- and 0+) calls,
  - b. calls to certain community information services in accordance with the Information Provider's applicable service rates when the Company performs the billing function for the Information Provider,
  - c. calls from an FGA line to another customer's service in accordance with that customer's applicable service rates when the Company performs the billing function for that customer.
8. When a FGA switching arrangement for an individual customer (a single line or entire hunt group) is discontinued at an end office, an intercept announcement is provided. This arrangement provides, for a limited period of time, an announcement that the service associated with the number dialed has been disconnected.
9. FX/ONAL FGA Switching can be ordered by an end user when used in conjunction with a Foreign Exchange (FX) service or an Off Network Access Line (ONAL) service. FX/ONAL FGA charges will be billed to the end user. FX/ONAL FGA Switching is not permitted for use with the provisioning of MTS/WATS-type service.

**NOTICE**  
**THE INFORMATION CONTAINED IN THIS DOCUMENT IS SUBJECT TO CHANGE.**

**Qwest Corporation**  
**Access Service**  
**Catalog No. 1**

**SECTION 6**  
Page 36  
Release 1  
Effective: 8-1-05

**NORTHERN IDAHO**  
Issued: 7-1-05

Effective: 8-1-05

---

**6. SWITCHED ACCESS SERVICE**

**6.2 PROVISION AND DESCRIPTION OF SWITCHED ACCESS SERVICE**

**6.2.1 FEATURE GROUP A (FGA) (Cont'd)**

B. Optional Features

1. Common Switching Optional Features

- Hunt Group Arrangement
- Uniform Call Distribution Arrangement
- Nonhunting Number for Use with Hunt Group Arrangement or Uniform Call Distribution Arrangement
- Call Denial
- Service Code Denial
- Feature Group A InterLATA Toll Denial

NOTICE  
THE INFORMATION CONTAINED IN THIS DOCUMENT IS SUBJECT TO CHANGE.

**Qwest Corporation**  
**Access Service**  
**Catalog No. 1**

**SECTION 6**  
Page 37  
Release 1  
Effective: 8-1-05

**NORTHERN IDAHO**  
Issued: 7-1-05

Effective: 8-1-05

## **6. SWITCHED ACCESS SERVICE**

### **6.2 PROVISION AND DESCRIPTION OF SWITCHED ACCESS SERVICE**

#### **6.2.1 FEATURE GROUP A (FGA)**

##### **B. Optional Features (Cont'd)**

#### **2. Transport Termination Optional Features**

- Two-way operation with dial pulse address signaling and loop start supervisory signaling
- Two-way operation with dial pulse address signaling and ground start supervisory signaling
- Two-way operation with dual tone multifrequency address signaling and loop start supervisory signaling
- Two-way operation with dual tone multifrequency address signaling and ground start supervisory signaling
- Terminating operation with dial pulse address signaling and loop start supervisory signaling
- Terminating operation with dial pulse address signaling and ground start supervisory signaling
- Terminating operation with dual tone multifrequency address signaling and loop start supervisory signaling
- Terminating operation with dual tone multifrequency address signaling and ground start supervisory signaling
- Originating operation with loop start supervisory signaling
- Originating operation with ground start supervisory signaling

#### **3. Switched Transport Optional Features**

- Supervisory Signaling
- Customer Specified Entry Switch Receive Level

**NOTICE**  
**THE INFORMATION CONTAINED IN THIS DOCUMENT IS SUBJECT TO CHANGE.**

**Qwest Corporation**  
**Access Service**  
**Catalog No. 1**

**SECTION 6**  
Page 38  
Release 1  
Effective: 8-1-05

**NORTHERN IDAHO**  
Issued: 7-1-05

Effective: 8-1-05

---

**6. SWITCHED ACCESS SERVICE**

**6.2 PROVISION AND DESCRIPTION OF SWITCHED ACCESS SERVICE**

**6.2.1 FEATURE GROUP A (FGA)**

B. Optional Features (Cont'd)

4. Where technically feasible and operating conditions permit, certain other features which may be available in connection with Feature Group A are provided under the Exchange and Network Services Catalog or Private Line Transport Catalog. These are:
  - Custom Calling Features
  - Remote Call Forwarding
  - Bill Number Screening
  - IntraLATA Extensions
  - Message Delivery Service
  - Message Waiting Indication
  - Queuing on UCD
  - Delay Announcement on UCD

**NOTICE**  
**THE INFORMATION CONTAINED IN THIS DOCUMENT IS SUBJECT TO CHANGE.**

**Qwest Corporation**  
**Access Service**  
**Catalog No. 1**

**SECTION 6**  
Page 39  
Release 1  
Effective: 8-1-05

**NORTHERN IDAHO**  
Issued: 7-1-05

Effective: 8-1-05

---

**6. SWITCHED ACCESS SERVICE**

**6.2 PROVISION AND DESCRIPTION OF SWITCHED ACCESS SERVICE**

**6.2.1 FEATURE GROUP A (FGA) (Cont'd)**

C. Transmission Performance

FGA is provided with Transmission Type B or Type C performance. The standard parameter limits associated with these Transmission Types are guaranteed to the first point of switching. Transmission Type C performance is provided with Interface Group 1 and Transmission Type B performance is provided with Interface Groups 2, 6 and 9, as available. Voiceband Data Transmission Type DB parameter limits are provided with FGA to the first point of switching as delineated in Technical Reference PUB GR-334-CORE.

D. Testing Capabilities

FGA is provided, in the terminating direction where equipment is available, with seven digit access to balance (100 type) test line and milliwatt (102 type) test line. In addition to the tests described in 6.1.5, preceding which are included with the installation of service, additional Cooperative Acceptance Testing and Nonscheduled Testing are available for FGA as set forth in 12.3.4, following.

**NOTICE**  
**THE INFORMATION CONTAINED IN THIS DOCUMENT IS SUBJECT TO CHANGE.**

**Qwest Corporation**  
**Access Service**  
**Catalog No. 1**

**SECTION 6**  
Page 40  
Release 1  
Effective: 8-1-05

**NORTHERN IDAHO**  
Issued: 7-1-05

**6. SWITCHED ACCESS SERVICE**

**6.2 PROVISION AND DESCRIPTION OF SWITCHED ACCESS SERVICE (Cont'd)**

**6.2.2 FEATURE GROUP B (FGB)**

A. Description

1. FGB Access provides trunkside access to Company end office switches for the customer's use in originating communications from and terminating communications to an Interexchange Carrier's intrastate service or a customer-provided intrastate communications capability. The customer must specify the Interexchange Carrier to which the FGB service is connected, or in the alternative, specify the means by which the FGB access communications is transported within the state.
2. FGB, when directly routed to an end office via DTT, is provided at appropriately equipped Company electronic end office switches. When provided via Company designated electronic access tandem switches with TST, FGB switching is provided at Company electronic and electromechanical end office switches.
3. When Feature Group B service is directly routed to an end office, the Switched Transport configuration is composed of an Entrance Facility and a DTT facility to an end office. When Feature Group B is switched through an access tandem, the Switched Transport configuration is composed of an Entrance Facility and TST to the end offices subtending the access tandem. The customer may also order DTT to an access tandem in conjunction with TST to the end offices subtending that tandem. Multiplexing options are described in 6.1.2, preceding.
4. FGB is provided as trunkside switching through the use of end office or access tandem switch trunk equipment. The Technical Specifications for these terminations are provided in Technical Reference PUB GR-334-CORE and associated addenda.
5. FGB switching is provided with multifrequency (MF) address signaling in both the originating and terminating directions. For address signaling format specifications see Technical Reference PUB GR-334-CORE and associated addenda.
6. The access code for non-8XX DB Access Service FGB switching is a uniform access code. The form of the uniform access code is 950-XXXX or 1+950-XXXX for carriers. These uniform access codes will be the assigned access numbers of all non-8XX DB Access Service FGB Switched Access Service provided to the customer by the Company. No access code is required for FGB switching used to provide 800 DB Access Service. The telephone number dialed by the customer's end users is of the form 1+8XX-NXX-XXXX.

**NOTICE**  
**THE INFORMATION CONTAINED IN THIS DOCUMENT IS SUBJECT TO CHANGE.**

**Qwest Corporation**  
**Access Service**  
**Catalog No. 1**

**SECTION 6**  
Page 41  
Release 1  
Effective: 8-1-05

**NORTHERN IDAHO**  
Issued: 7-1-05

**6. SWITCHED ACCESS SERVICE**

**6.2 PROVISION AND DESCRIPTION OF SWITCHED ACCESS SERVICE**

**6.2.2 FEATURE GROUP B (FGB)**

A. Description (Cont'd)

7. FGB switching, when used in the terminating direction, may be used to access valid NXX codes in the LATA, community information services of an information service provider and other customers' services (by dialing the appropriate digits). When FGB is directly routed to an end office via DTT, only those valid NXX codes served by that end office may be accessed. When FGB is routed through an access tandem, only those valid NXX codes served by end offices subtending the access tandem may be accessed. The customer will also be billed additional non-access charges for calls to certain community information services in accordance with the Information Provider's applicable service rates when the Company performs the billing function for that Information Provider. Additional, non-access charges will be billed for calls from a FGB trunk to another customer's service in accordance with that customer's applicable service rates when the Company performs the billing function for that customer. Calls in the terminating direction will not be completed to 950-XXXX (or 1+950-XXXX) access codes, local operator assistance (0- and 0+), Directory Assistance (411 or 555-1212, where available), service codes 611 and 911 or 101XXXX access code. FGB may not be switched, in the terminating direction, to another Trunkside Switched Access Service.
8. The Company will establish a trunk group or groups for the customer at end office switches or access tandem switches where FGB switching is provided. When required by technical limitations, a separate trunk group will be established for each type of FGB switching arrangement provided. Different types of FGB or other switching arrangements may be combined in a single trunk group at the option of the Company.
9. When all FGB switching arrangements are discontinued at an end office and/or in a LATA, an intercept announcement is provided. This arrangement provides, for a limited period of time, an announcement that the service associated with the number dialed has been disconnected.

**NOTICE**  
**THE INFORMATION CONTAINED IN THIS DOCUMENT IS SUBJECT TO CHANGE.**

**Qwest Corporation**  
**Access Service**  
**Catalog No. 1**

**SECTION 6**  
Page 42  
Release 1  
Effective: 8-1-05

.3  
**NORTHERN IDAHO**  
Issued: 7-1-05

---

**6. SWITCHED ACCESS SERVICE**

**6.2 PROVISION AND DESCRIPTION OF SWITCHED ACCESS SERVICE**  
**6.2.2 FEATURE GROUP B (FGB) (Cont'd)**

B. Optional Features

1. Common Switching Optional Features

- Automatic Number Identification (ANI)
- Up to 7 Digit Outpulsing of Access Digits to Customer
- Alternate Traffic Routing

2. Switched Transport Optional Features

- Customer Specification of Switched Transport Termination
- Supervisory Signaling
- Customer Specified Entry Switch Receive Level

3. Another feature, Billed Number Screening, may be available in connection with FGB.

C. Transmission Performance

FGB is provided with Transmission Type B1 performance. Transmission Type B1 standard parameter limits apply to the transmission path routed directly (i.e., between the customer's premises and the end office) and to each segment of an access tandem connection. Transmission Type B1 performance is provided with Interface Groups 1, 2, 6 and 9, as available. Voice band data Transmission Type DB1 parameter limits are provided with FGB when routed directly and to each segment of an access tandem connection as delineated in Technical Reference GR-334-CORE.

**NOTICE**  
**THE INFORMATION CONTAINED IN THIS DOCUMENT IS SUBJECT TO CHANGE.**

**Qwest Corporation**  
**Access Service**  
**Catalog No. 1**

**SECTION 6**  
Page 43  
Release 1  
Effective: 8-1-05

**NORTHERN IDAHO**  
Issued: 7-1-05

Effective: 8-1-05

## **6. SWITCHED ACCESS SERVICE**

### **6.2 PROVISION AND DESCRIPTION OF SWITCHED ACCESS SERVICE**

#### **6.2.2 FEATURE GROUP B (FGB) (Cont'd)**

##### **D. Testing Capabilities**

FGB is provided, in the terminating direction where equipment is available, with seven digit access to balance (100 type) test line, milliwatt (102 type) test line, nonsynchronous or synchronous test line, automatic transmission measuring (105 type) test line, data transmission (107 type) test line, loop around test line, short circuit test line and open circuit test line. In addition to the tests described in 6.1.5, preceding, which are included with the installation of service, additional Cooperative Acceptance Testing, Automatic Scheduled Testing, Cooperative Scheduled Testing, Manual Scheduled Testing and Nonscheduled Testing are available for FGB as set forth in 12.3.4, following.

#### **6.2.3 FEATURE GROUP C (FGC)**

##### **A. Description**

1. FGC Access, which is available only to providers of MTS and WATS, provides trunkside access to Company end office switches for the customer's use in originating and terminating communications.
2. FGC is provided at all Company end office switches on a direct trunk basis via DTT or via Company designated access tandem switches with TST. FGC switching is provided to the customer (i.e., providers of MTS and WATS) at an end office switch unless Feature Group D end office switching is provided in the same office. When FGD switching is available, FGC switching will not be provided.
3. When Feature Group C service is directly routed to an end office, the Switched Transport configuration is composed of an Entrance Facility and a DTT facility to an end office. When Feature Group C is switched through an access tandem, the Switched Transport configuration is composed of an Entrance Facility and TST to the end offices subtending the access tandem. The customer may also order DTT to an access tandem in conjunction with TST to the end offices subtending that tandem. Multiplexing options are described in 6.1.2, preceding.
4. FGC is provided as trunkside switching through the use of end office or access tandem switch trunk equipment. The Technical Specifications for these terminations are provided in Technical Reference PUB GR-334-CORE and associated addenda.

**NOTICE**  
**THE INFORMATION CONTAINED IN THIS DOCUMENT IS SUBJECT TO CHANGE.**

**Qwest Corporation**  
**Access Service**  
**Catalog No. 1**

**SECTION 6**  
Page 44  
Release 1  
Effective: 8-1-05

**NORTHERN IDAHO**  
Issued: 7-1-05

**6. SWITCHED ACCESS SERVICE**

**6.2 PROVISION AND DESCRIPTION OF SWITCHED ACCESS SERVICE**

**6.2.3 FEATURE GROUP C (FGC)**

A. Description (Cont'd)

5. No access code is required for FGC switching. The telephone number dialed by the customer's end user shall be a seven digit number for calls in the North American Numbering Plan (NANP). The form of the numbers dialed by the customer's end user in their own NPA is NXX-XXXX, 0 or 1 + NXX-XXXX.
6. FGC switching, when used in the terminating direction, may be used to access valid NXX codes in the LATA, community information services of an information provider, and other customers' services (by dialing the appropriate codes) when the services can be reached using valid NXX codes. When FGC is directly routed to an end office via DTT, only those valid NXX codes served by that end office may be accessed. When FGC is routed through an access tandem, only those valid NXX codes served by end offices subtending the access tandem may be accessed. Where measurement capabilities exist, the customer will also be billed additional non-access charges for calls to certain community information services in accordance with the Information Provider's applicable service rates when the Company performs the billing function for that Information Provider. Additional non-access charges will be billed for calls from a FGC trunk to another customer's service in accordance with that customer's applicable service rates when the Company performs the billing function for that customer. Calls in the terminating direction will not be completed to 950-XXXX (or 1+950-XXXX) access codes, local operator assistance (0- and 0+), Directory Assistance (411 or 555-1212), service codes 611, 911 or 101XXXX access code. FGC may not be switched, in the terminating direction, to another Trunkside Switched Access Service.
7. The Company will establish a trunk group or groups for the customer at end office switches or access tandem switches where FGC switching is provided. When required by technical limitations, a separate trunk group will be established for each type of FGC switching arrangement provided. Different types of FGC or other switching arrangements may be combined in a single trunk group at the option of the Company.

**NOTICE**  
**THE INFORMATION CONTAINED IN THIS DOCUMENT IS SUBJECT TO CHANGE.**

**Qwest Corporation**  
**Access Service**  
**Catalog No. 1**

**SECTION 6**  
Page 45  
Release 1  
Effective: 8-1-05

**NORTHERN IDAHO**  
Issued: 7-1-05

**6. SWITCHED ACCESS SERVICE**

**6.2 PROVISION AND DESCRIPTION OF SWITCHED ACCESS SERVICE**

**6.2.3 FEATURE GROUP C (FGC)**

A. Description (Cont'd)

8. The Company will provide 1+ interLATA sent-paid access from pay telephones utilizing Smart Public Access Lines via FGC for calls dialed as 1+ and/or 101XXXX 1+ in the following manner. 1+ interLATA sent-paid access from pay telephones utilizing Basic Public Access Lines Service shall be provided by FGD.
  - a. Smart Public Access Line (PAL)

For traffic originating from a Smart PAL, the customer to whom such calls are routed shall order FGC trunks from end offices to the customer's premises via direct trunks or via Operator Access Tandems, with the Operator Trunk-Full Feature type of transport termination, as set forth in 6.3.2, following. The trunks must be dedicated, and the customer shall specify the number of trunks required at each end office from which the customer will receive 1+ sent-paid traffic.

The customer is responsible for providing all other operator services signaling capabilities, as described in the Operator Services Systems Generic Requirements (OSSGR) Technical Reference FR-271 and the LATA Switching Systems Generic Requirements (LSSGR) Technical Reference FR-64.

When the Company provides Operator Services Signaling (OSS) between an Operator Access Tandem and the customer's premises, the customer will be required to order a separate and final trunk group from the Operator Access Tandem to the customer's premises for each Numbering Plan Area (NPA) within a LATA to identify the originating NPA. Also, the customer must order a separate trunk group for each type of coin control signaling that is utilized among the equal access end offices subtending an Operator Access Tandem.

The Company will not block 101XXXX 1+ calls and will route 101XXXX 1+ interLATA sent-paid traffic in accordance to the end user request. It will be the responsibility of the 101XXXX 1+ dialed carrier to complete the casual 101XXXX 1+ interLATA sent-paid call or to provide a recorded message to the end user.

**NOTICE**  
**THE INFORMATION CONTAINED IN THIS DOCUMENT IS SUBJECT TO CHANGE.**

**Qwest Corporation**  
**Access Service**  
**Catalog No. 1**

**SECTION 6**  
Page 46  
Release 1  
Effective: 8-1-05

**NORTHERN IDAHO**  
Issued: 7-1-05

---

**6. SWITCHED ACCESS SERVICE**

**6.2 PROVISION AND DESCRIPTION OF SWITCHED ACCESS SERVICE**

**6.2.3 FEATURE GROUP C (FGC)**

A.8.a. (Cont'd)

The Company will perform normal acceptance testing for sent-paid services for Smart PALs. In addition, the Company will perform testing for coin control and Operator Trunk-Full Feature (i.e., coin collect, coin return, 1+ person-to-person, operator recall, overtime and information calls). Test tapes must be received from the customer that will be processing the 1+ interLATA sent-paid traffic 45 days prior to the routing of said 1+ traffic to that customer. The Company will provide optional testing, at the request of the customer, as set forth in Section 12, following.

NOTICE  
THE INFORMATION CONTAINED IN THIS DOCUMENT IS SUBJECT TO CHANGE.

**Qwest Corporation**  
**Access Service**  
**Catalog No. 1**

**SECTION 6**  
Page 47  
Release 1  
Effective: 8-1-05

**NORTHERN IDAHO**  
Issued: 7-1-05

Effective: 8-1-05

---

**6. SWITCHED ACCESS SERVICE**

**6.2 PROVISION AND DESCRIPTION OF SWITCHED ACCESS SERVICE**

**6.2.3 FEATURE GROUP C (FGC) (Cont'd)**

B. Optional Features

1. Common Switching Optional Features

- Automatic Number Identification (ANI)
- Service Class Routing
- Dial Pulse Address Signaling
- Delay Dial Start-Pulsing Signaling
- Immediate Dial Pulse Address Signaling
- Alternate Traffic Routing
- Trunk Access Limitation
- WATS Access Service

2. Transport Termination Optional Features

Operator Trunks - (i.e., Coin, Non-Coin, and Combined Coin and Non-Coin.)

3. Switched Transport Optional Features

- Supervisory Signaling
- MPTS

**NOTICE**  
**THE INFORMATION CONTAINED IN THIS DOCUMENT IS SUBJECT TO CHANGE.**

**Qwest Corporation**  
**Access Service**  
**Catalog No. 1**

**SECTION 6**  
Page 48  
Release 1  
Effective: 8-1-05

**NORTHERN IDAHO**  
Issued: 7-1-05

Effective: 8-1-05

**6. SWITCHED ACCESS SERVICE**

**6.2 PROVISION AND DESCRIPTION OF SWITCHED ACCESS SERVICE**

**6.2.3 FEATURE GROUP C (FGC) (Cont'd)**

C. Transmission Performance

FGC is provided with Transmission Type B1 performance. Transmission Type B1 standard parameter limits apply to the transmission path routed directly (i.e., between the customer's premises and the end office) and to each segment of an access tandem connection. Transmission Type B1 performance is provided with Interface Groups 1, 2, 6 and 9, as available. Voice band data Transmission Type DB1 parameter limits are provided with FGC when directly routed and to each segment of an access tandem connection as delineated in Technical Reference GR-334-CORE.

D. Testing Capabilities

FGC is provided, in the terminating direction where equipment is available, with seven digit access to balance (100 type) test line, milliwatt (102 type) test line, nonsynchronous or synchronous test line, automatic transmission measuring (105 type) test line, data transmission (107 type) test line, loop around test line, short circuit test line and open circuit test line. In addition to the tests described in 6.1.5, preceding, which are included with the installation of service, additional Cooperative Acceptance Testing, Automatic Scheduled Testing, Cooperative Scheduled Testing or Manual Scheduled Testing, and Nonscheduled Testing are available for FGC as set forth in 12.3.4, following.

**NOTICE**  
**THE INFORMATION CONTAINED IN THIS DOCUMENT IS SUBJECT TO CHANGE.**

**Qwest Corporation**  
**Access Service**  
**Catalog No. 1**

**SECTION 6**  
Page 49  
Release 1  
Effective: 8-1-05

**NORTHERN IDAHO**  
Issued: 7-1-05

**6. SWITCHED ACCESS SERVICE**

**6.2 PROVISION AND DESCRIPTION OF SWITCHED ACCESS SERVICE (Cont'd)**

**6.2.4 FEATURE GROUP D (FGD)**

A. Description

1. FGD is provided at Company designated electronic end office switches whether routed directly via DTT or via Company designated access tandem switches with TST or routed directly via a DTT facility equipped with TSI where the Company equal access end office subtends a TSP's premises.
2. FGD is provided as trunkside switching through the use of end office or access tandem switch trunk equipment. The Technical Specifications for these terminations are provided in Technical Reference PUB GR-334-CORE and associated addenda.
3. When Feature Group D service is directly routed to an end office, the Switched Transport configuration is composed of an Entrance Facility and a DTT facility to an end office. When Feature Group D is switched through an access tandem, the Switched Transport configuration is composed of an Entrance Facility and TST to the end offices subtending the access tandem. The customer may also order DTT to an access tandem in conjunction with TST to the end offices subtending that tandem. Multiplexing options are described in 6.1.2, preceding.
4. FGD switching, when used in the terminating direction, may be used to access valid NXX codes in the LATA, community information services of an information service provider, and other customers' services (by dialing the appropriate codes) when such services can be reached using valid NXX codes. When directly routed to an end office via DTT, only those valid NXX codes served by that end office may be accessed. When FGD is routed through an access tandem, only those valid NXX codes served by end offices subtending the access tandem may be accessed. The customer will also be billed additional non-access charges for calls to certain community information services in accordance with the Information Provider's applicable service rates when the Company performs the billing function for that Information Provider.
5. Terminating FGD, when routed via TST, may also, at the option of the customer, access valid NXX codes served by end offices in which originating FGD is not available. Rating of this optional service is as set forth in 6.7.1.D., following.

**NOTICE**  
**THE INFORMATION CONTAINED IN THIS DOCUMENT IS SUBJECT TO CHANGE.**

**Qwest Corporation**  
**Access Service**  
**Catalog No. 1**

**SECTION 6**  
Page 50  
Release 1  
Effective: 8-1-05

**NORTHERN IDAHO**  
Issued: 7-1-05

**6. SWITCHED ACCESS SERVICE**

**6.2 PROVISION AND DESCRIPTION OF SWITCHED ACCESS SERVICE**

**6.2.4 FEATURE GROUP D (FGD)**

A. Description (Cont'd)

6. Additional, non-access charges will be billed for calls from a FGD trunk to another customer's service in accordance with that customer's applicable service rates when the Company performs the billing function for that customer. Calls in the terminating direction will not be completed to 950-XXXX (or 1+950-XXXX) access codes, local operator assistance (0- and 0+), Directory Assistance (411 and 555-1212), service codes 611, 911 or 101XXXX access code. FGD may not be switched, in the terminating direction, to another Trunkside Switched Access Service.
7. The Company will establish a trunk group or groups for the customer at end office switches or access tandem switches where FGD switching is provided. When required by technical limitations, a separate trunk group will be established for each type of FGD switching arrangement provided. Different types of FGD or other switching arrangements may be combined in a single trunk group at the option of the Company.
8. The access code for FGD switching is a uniform access code of the form 101XXXX. These uniform access codes will be the assigned access numbers of all FGD access provided to the customer by the Company. No access code is required for calls to a customer over FGD Switched Access Service if the end user's telephone exchange service is arranged for presubscription to that customer, as set forth in 12.3.3, following.
  - a. Where no access code is required, the number dialed by the customer's end user shall be a seven digit number for calls in the North American Numbering Plan (NANP). The form of the numbers dialed by the customer's end user in their own NPA is NXX-XXXX, 0, 00 or 1 + NXX-XXXX.
  - b. When the 101XXXX access code is used, FGD switching also provides for dialing the digit 0 or 00 for access to the customer's operator, 911 for access to the Company's emergency reporting service, or at the customer's option, the end-of-dialing digit (#) for cut-through access to the customer's premises.
9. FGD switching will be arranged to accept calls from telephone exchange service locations without the need for dialing 101XXXX uniform access code. Each telephone exchange service line may be marked with a presubscription code to identify which 101XXXX code its calls will be directed to for interLATA service. Presubscription codes are applied as set forth in 12.3.3, following.

**NOTICE**  
**THE INFORMATION CONTAINED IN THIS DOCUMENT IS SUBJECT TO CHANGE.**

**Qwest Corporation**  
**Access Service**  
**Catalog No. 1**

**SECTION 6**  
Page 51  
Release 1  
Effective: 8-1-05

**NORTHERN IDAHO**  
Issued: 7-1-05

**6. SWITCHED ACCESS SERVICE**

**6.2 PROVISION AND DESCRIPTION OF SWITCHED ACCESS SERVICE**

**6.2.4 FEATURE GROUP D (FGD)**

A. Description (Cont'd)

10. The Company will provide 1+ interLATA sent-paid access from equal access end offices to the customer's premises for calls dialed as 1+ and/or 101XXXX 1+ from pay telephones utilizing PAL Service, Smart and Basic, in the following manner.

- a. Smart PAL

For traffic originating from a Smart PAL, the customer to whom such calls are routed shall order FGD trunks from equal access end offices to the customer's premises via direct trunks or via Operator Access Tandems, with the Operator Trunk-Full Feature type of transport termination, as set forth in 6.3.2, following. The trunks must be dedicated, and the customer shall specify the number of trunks required at each end office from which the customer will receive 1+ sent-paid traffic.

The customer is responsible for providing all other operator services signaling capabilities, as described in the Operator Services Systems Generic Requirements (OSSGR) Technical Reference FR-271 and the LATA Switching Systems Generic Requirements (LSSGR) Technical Reference FR-64.

When the Company provides Operator Services Signaling (OSS) between an Operator Access Tandem and the customer's premises, the customer will be required to order a separate and final trunk group from the Operator Access Tandem to the customer's premises for each Numbering Plan Area (NPA) within a LATA to identify the originating NPA. Also, the customer must order a separate trunk group for each type of coin control signaling that is utilized among the equal access end offices subtending an Operator Access Tandem.

**NOTICE**  
**THE INFORMATION CONTAINED IN THIS DOCUMENT IS SUBJECT TO CHANGE.**

**Qwest Corporation**  
**Access Service**  
**Catalog No. 1**

**SECTION 6**  
Page 52  
Release 1  
Effective: 8-1-05

**NORTHERN IDAHO**  
Issued: 7-1-05

---

**6. SWITCHED ACCESS SERVICE**

**6.2 PROVISION AND DESCRIPTION OF SWITCHED ACCESS SERVICE**

**6.2.4 FEATURE GROUP D (FGD)**

A.10.a. (Cont'd)

The Company will not block 101XXXX 1+ calls and will route 101XXXX 1+ interLATA sent-paid traffic in accordance to the end user request. It will be the responsibility of the 101XXXX 1+ dialed carrier to complete the casual 101XXXX 1+ interLATA sent-paid call or to provide a recorded message to the end user.

The Company will perform normal acceptance testing for sent-paid services for Smart PALs. In addition, the Company will perform testing for coin control and Operator Trunk-Full Feature (i.e., coin collect, coin return, 1+ person-to-person, operator recall, overtime and information calls). Test tapes must be received from the customer that will be processing the 1+ interLATA sent-paid traffic 45 days prior to the routing of said 1+ traffic to that customer. The Company will provide optional testing, at the request of the customer, as set forth in Section 12, following.

b. Basic PAL

For traffic originating from a Basic PAL, the Company shall provide 1+ interLATA sent-paid access from equal access end offices to the customer's premises via FGD trunks. For traffic originating from a Basic PAL dialed as 1+ and/or 101XXXX 1+, the customer to whom such calls are routed shall order or have existing FGD trunks with ANI optional feature, as set forth in 6.3.1, following.

**NOTICE**  
**THE INFORMATION CONTAINED IN THIS DOCUMENT IS SUBJECT TO CHANGE.**

**Qwest Corporation**  
**Access Service**  
**Catalog No. 1**

**SECTION 6**  
Page 53  
Release 1  
Effective: 8-1-05

**NORTHERN IDAHO**  
Issued: 7-1-05

Effective: 8-1-05

---

**6. SWITCHED ACCESS SERVICE**

**6.2 PROVISION AND DESCRIPTION OF SWITCHED ACCESS SERVICE**

**6.2.4 FEATURE GROUP D (FGD) (Cont'd)**

B. Optional Features

1. Common Switching Optional Features

- Automatic Number Identification (ANI)
- Service Class Routing
- Alternate Traffic Routing
- Trunk Access Limitation
- Cut-Through
- WATS Access Service
- SS7 Out of Band Signaling
- Clear Channel Capability

2. Transport Termination Optional Features

- Operator Trunk, Full Feature
- Operator Trunks - (i.e., Coin, Non-coin, and Combined Coin and Non-Coin)

3. Switched Transport Optional Features

- Supervisory Signaling
- MPTS

**NOTICE**  
**THE INFORMATION CONTAINED IN THIS DOCUMENT IS SUBJECT TO CHANGE.**

**Qwest Corporation**  
**Access Service**  
**Catalog No. 1**

**SECTION 6**  
Page 54  
Release 1  
Effective: 8-1-05

**NORTHERN IDAHO**  
Issued: 7-1-05

---

**6. SWITCHED ACCESS SERVICE**

**6.2 PROVISION AND DESCRIPTION OF SWITCHED ACCESS SERVICE**  
**6.2.4 FEATURE GROUP D (FGD) (Cont'd)**

C. Transmission Performance

FGD is provided with either Transmission Type A1 or Type B1 performance as follows:

- When routed directly to the end office, Transmission Type B1 is provided.
- When routed to an access tandem, only Transmission Type A1 is provided for both the POT-to-access tandem and access tandem-to-end office trunks.
- Overall POT to end office requirements for FGD provide Transmission Type B1 performance whether routed directly with Transmission Type B1 or via an access tandem with Transmission Type A1.

Transmission Type B1 performance is provided with Interface Groups 1, 2, 6 and 9, as available. Transmission Type A1 performance is provided with Interface Groups 2, 6 and 9, as available.

Voice band data Transmission Type DB1 parameter limits are provided with FGD for the transmission path between the customer's premises and the end office when directly routed to the end office. Voice band data Transmission Type DA1 parameter limits are provided for the transmission path between the customer's premises and the access tandem and between the access tandem and the end office. Voice band data transmission parameter limits are delineated in Technical Reference PUB GR-334-CORE.

D. Testing Capabilities

FGD is provided, in the terminating direction where equipment is available, with seven digit access to balance (100 type) test line, milliwatt (102 type) test line, nonsynchronous or synchronous test line, automatic transmission measuring (105 type) test line, data transmission (107 type) test line, loop around test line, short circuit test line, open circuit test line and non-inverting digital loopback (108 type) test line.

In addition to the tests described in 6.1.5, preceding, which are included with the installation of service, additional Cooperative Acceptance Testing, Automatic Scheduled Testing, Cooperative Scheduled Testing, Manual Scheduled Testing, and Nonscheduled Testing, are available for FGD as set forth in 12.3.4, following.

**NOTICE**  
**THE INFORMATION CONTAINED IN THIS DOCUMENT IS SUBJECT TO CHANGE.**

**Qwest Corporation**  
**Access Service**  
**Catalog No. 1**

**SECTION 6**  
Page 55  
Release 1  
Effective: 8-1-05

**NORTHERN IDAHO**  
Issued: 7-1-05

**6. SWITCHED ACCESS SERVICE**

**6.2 PROVISION AND DESCRIPTION OF SWITCHED ACCESS SERVICE (Cont'd)**

**6.2.5 800 DATA BASE ACCESS SERVICE**

A. General Description

800 Data Base (800 DB) Access Service is an originating service utilizing Trunkside Switched Access Service which provides for the forwarding of end user dialed 800+NXX-XXXX calls to a customer based on the dialed 8XX number. 800 DB Access Service must be ordered to all end offices in a LATA and provisioned, at a minimum, to all access tandems[1] and operator switches equipped as SSPs within a LATA. In addition, the provision of 800 DB Access Service requires the customer's direct access to the Service Management System/800 (SMS/800), or as an alternative, the provision of such service by a Responsible Organization in accordance with the Guidelines for 800 Data Base.

When an 8XX call is originated by an end user, the Company will perform the customer identification function based on the dialed digits to determine the customer location to which the call is to be routed in accordance with SMS/800 information residing in the Company's Service Control Point (SCP).

The customer has the option of having the dialed 8XX number (i.e., 8XX+NXX-XXXX or the translated Plain Old Telephone Service (POTS) number (i.e., NPA+NXX-XXXX) delivered. If the translated POTS number is delivered, the customer must request the POTS Translation vertical feature through the Responsible Organization as described in B., following. The service provider will be unable to determine that such calls originated as 1+8XX+NXX-XXXX dialed calls unless the customer also orders the Automatic Number Identification (ANI) feature through the Company as described in 6.3.1, following.

800 DB Access Service provided from an equal access end office will be provisioned from the SSP switch as Feature Group D. Calls originating from end offices not equipped with equal access capabilities will be converted at the SSP switch to standard Feature Group D format.

[1] 800 Data Base Access Service is not provided via a DTT facility equipped with Tandem Signaling Information.

**NOTICE**  
**THE INFORMATION CONTAINED IN THIS DOCUMENT IS SUBJECT TO CHANGE.**

**Qwest Corporation**  
**Access Service**  
**Catalog No. 1**

**SECTION 6**  
Page 56  
Release 1  
Effective: 8-1-05

**NORTHERN IDAHO**  
Issued: 7-1-05

**6. SWITCHED ACCESS SERVICE**

**6.2 PROVISION AND DESCRIPTION OF SWITCHED ACCESS SERVICE**

**6.2.5 800 DATA BASE ACCESS SERVICE**

A. General Description (Cont'd)

When the customer orders 800 DB Access Service for the transmission of both voice and data traffic, the customer must order Clear Channel Capability (CCC) for provisioning of its data traffic.

The customer's 8XX Access Service voice or data traffic may be combined in the same trunk group arrangement with the customer's non-8XX Access Service voice or data traffic or provisioned on a separate trunk group, unless prohibited by technical limitations.

Measurement of 800 DB Access Service usage shall be in accordance with the regulations set forth in 6.7.6, following, for Trunkside Switched Access Service. Specifically, 800 DB Access Service originating usage, whether combined with non-8XX Access Service usage on trunk groups or provided using dedicated trunk groups, shall be measured in the same manner as specified for non-8XX Access Service usage over Trunkside Switched Access Service.

The Company must be notified twenty-four (24) hours prior to any media stimulation. The Company maintains the right to apply protective controls, i.e., those actions such as call gapping, to ensure the provisioning of acceptable service to all telecommunications users of the Company's network services.

Application of rates for 800 DB Access Service shall be as set forth in 6.7.1, following.

B. Vertical Features

In addition to the basic carrier identification function, 800 DB Access Service subscribers may request vertical features through a Responsible Organization in accordance with the SMS/800 User Guide, BR 780-004-221. Vertical features will be maintained within the Company's SCP when technically feasible. The POTS Translation feature is described in 1., following, and the Call Handling and Destination Features are described in 2., following.

**NOTICE**  
**THE INFORMATION CONTAINED IN THIS DOCUMENT IS SUBJECT TO CHANGE.**

**Qwest Corporation**  
**Access Service**  
**Catalog No. 1**

**SECTION 6**  
Page 57  
Release 1  
Effective: 8-1-05

**NORTHERN IDAHO**  
Issued: 7-1-05

---

**6. SWITCHED ACCESS SERVICE**

**6.2 PROVISION AND DESCRIPTION OF SWITCHED ACCESS SERVICE**

**6.2.5 800 DATA BASE ACCESS SERVICE**

B. Vertical Features (Cont'd)

1. POTS Translation

The POTS Translation vertical feature provides the option of having the ten digit POTS number (i.e., NPA+NXX-XXXX) delivered instead of the 8XX dialed number (i.e., 8XX+NXX-XXXX) delivered to the service provider. If the POTS Translation feature is requested through the Responsible Organization, the service provider will be unable to determine that such calls originated as 1+8XX+NXX-XXXX dialed calls unless the service provider also orders, through the Company, the Automatic Number Identification (ANI) optional feature as described in 6.3.1, following. ANI information digits of "24" indicating that the call originated as an 8XX dialed call is delivered when the ANI optional feature is ordered.

A POTS Translation Charge as described in 6.7.1, following, is assessed to the service provider for each 8XX call delivered.

2. Call Handling and Destination Features

Call Handling and Destination Features allow service subscribers variable routing options by specifying a single carrier, multiple carriers (Exchange and/or Interexchange Carriers), single termination or multiple terminations. Multiple terminations require the POTS Translation feature described in 1., preceding. The following variable routing options are available:

- Routing by Originating NPA+NXX-XXXX - Time of Day
- Day of Week
- Specific Date
- Allocation by Percentage

Routing by originating NPA+NXX-XXXX, where technically feasible, allows a service subscriber to specify one or more multiple terminations with a single carrier and/or multiple carriers (Exchange and/or Interexchange Carriers) based on where a call originates.

**NOTICE**  
**THE INFORMATION CONTAINED IN THIS DOCUMENT IS SUBJECT TO CHANGE.**

**Qwest Corporation**  
**Access Service**  
**Catalog No. 1**

**SECTION 6**  
Page 58  
Release 1  
Effective: 8-1-05

**NORTHERN IDAHO**  
Issued: 7-1-05

Effective: 8-1-05

---

**6. SWITCHED ACCESS SERVICE**

**6.2 PROVISION AND DESCRIPTION OF SWITCHED ACCESS SERVICE**

**6.2.5 800 DATA BASE ACCESS SERVICE**

B.2. (Cont'd)

Time of Day/Day of Week allows a service subscriber to specify one or more multiple terminations with a single carrier and/or multiple carriers (Exchange and/or Interexchange Carriers) based on the time of day or day of week the call originates.

Specific Date allows the service subscriber to specify alternate service routes with the date the call originates. These calls can be routed to one of multiple terminations, with a single carrier and/or multiple carriers (Exchange and/or Interexchange Carriers).

Allocation by Percentage allows the service subscriber to specify by percentage the calls to be allocated to multiple terminations and/or multiple carriers (Exchange and/or Interexchange Carriers).

A Call Handling and Destination Feature Query Charge as described in 6.7.1, following, is assessed to the service provider for each 8XX query to the SCP which utilizes one or more of the Call Handling and Destination Features.

**NOTICE**  
**THE INFORMATION CONTAINED IN THIS DOCUMENT IS SUBJECT TO CHANGE.**

**Qwest Corporation**  
**Access Service**  
**Catalog No. 1**

**SECTION 6**  
Page 59  
Release 1  
Effective: 8-1-05

**NORTHERN IDAHO**  
Issued: 7-1-05

Effective: 8-1-05

**6. SWITCHED ACCESS SERVICE**

**6.2 PROVISION AND DESCRIPTION OF SWITCHED ACCESS SERVICE (Cont'd)**

**6.2.6 900 ACCESS SERVICE**

900 Access Service is an originating service utilizing Trunkside Switched Access Service. The service provides a customer identification function based on the dialed NXX. When a 1+900+NXX-XXXX or 0+900+NXX-XXXX call is originated by the end user, the Company will determine, based on the NXX dialed, the customer to which the 900 call is to be routed. This six-digit routing function will be performed at suitably equipped end office and access tandem switches as determined by the Company.

The manner in which 900 Access Service is provisioned is dependent on the status of the end office which serves the end user customer who places a 900 call (i.e., equipped or not equipped with equal access capability) and/or the status of the customer (i.e., MTS/WATS provider or MTS/WATS-type provider). When 900 Access Service is provided from an end office equipped with equal access capability, all such service will be provisioned as Feature Group D or 900 Access Service. When 900 Access Service is provided from an end office not equipped with equal access capability, such service will be provisioned as Feature Group C or 900 Access Service utilizing traditional signaling with answer supervision.

900 Access Service is available only as a LATA wide service and must be provisioned to all offices within the LATA. 900 Access Service may be provisioned with 1+900+NXX-XXXX dialing capability or expanded to include 0+900+NXX-XXXX dialing capability. The Expanded 900 Option is not offered without 1+900 Access Service within a LATA and is available only with Feature Group D Service in suitably equipped Company end offices.

**NOTICE**  
**THE INFORMATION CONTAINED IN THIS DOCUMENT IS SUBJECT TO CHANGE.**

**Qwest Corporation**  
**Access Service**  
**Catalog No. 1**

**SECTION 6**  
Page 60  
Release 1  
Effective: 8-1-05

**NORTHERN IDAHO**  
Issued: 7-1-05

---

**6. SWITCHED ACCESS SERVICE**

**6.2 PROVISION AND DESCRIPTION OF SWITCHED ACCESS SERVICE**  
**6.2.6 900 ACCESS SERVICE (Cont'd)**

Calls originating in a LATA in which the customer has not ordered 900 Access Service will be blocked. Only customers who order the Expanded 900 (i.e., 0+900+NXX-XXXX) Option will be able to receive 0+900 calls to NXX codes assigned to them. In addition, calls originating in a LATA for which 900 Access Service has been established will be blocked utilizing the blocking specifications as follows:

- 1+900+NXX-XXXX will be blocked from coin telephones (except customer-owned coin operated telephones), 0+, 101XXXX, Inmate Service, Hotel/Motel Service (except those with customer-owned rating services).
- 0+900+NXX-XXXX will be blocked from 101XXXX and Inmate Service.

At the option of the customer, 900 Access Service traffic may be collected at suitably equipped end offices and/or access tandems. However, the customer must collect 900 traffic at all access tandems within the LATA. Network constraints do not permit multiple tandem arrangements for routing of 900 traffic.

**NOTICE**  
**THE INFORMATION CONTAINED IN THIS DOCUMENT IS SUBJECT TO CHANGE.**

**Qwest Corporation**  
**Access Service**  
**Catalog No. 1**

**SECTION 6**  
Page 61  
Release 1  
Effective: 8-1-05

**NORTHERN IDAHO**  
Issued: 7-1-05

---

**6. SWITCHED ACCESS SERVICE**

**6.2 PROVISION AND DESCRIPTION OF SWITCHED ACCESS SERVICE**  
**6.2.6 900 ACCESS SERVICE (Cont'd)**

For 900 Access Service provisioned as Feature Group C or D, the customer may establish a separate trunk group or combine 900 traffic with other traffic types for access from suitably equipped end offices and access tandems. For 900 Access Service provisioned with traditional signaling and answer supervision, network limitations require routing of 900 traffic from suitably equipped end offices and access tandems via a dedicated trunk group. Additionally, only 900 traffic will be routed over the dedicated trunk group.

Measurement of 900 Access Service usage shall be in accordance with the regulations set forth in 6.7.6, following, for Feature Groups C and D. Specifically, 900 Access Service originating usage shall be measured in the same manner as that specified for Feature Groups C and D, whether provisioned separately (i.e., dedicated trunk group) or combined with other traffic types.

The Company must be notified 24 hours prior to any media stimulation. The Company maintains the right to apply protective controls, i.e., those actions such as call gapping, to ensure the provisioning of acceptable service to all telecommunications users of the Company's network services.

The rates and charges for 900 Access Service are described in 6.7.1, following.

**NOTICE**  
**THE INFORMATION CONTAINED IN THIS DOCUMENT IS SUBJECT TO CHANGE.**

**Qwest Corporation**  
**Access Service**  
**Catalog No. 1**

**SECTION 6**  
Page 62  
Release 1  
Effective: 8-1-05

**NORTHERN IDAHO**  
Issued: 7-1-05

**6. SWITCHED ACCESS SERVICE**

**6.3 COMMON SWITCHING AND TRANSPORT TERMINATION OPTIONAL FEATURES**

Following are descriptions of the various optional features that are available in lieu of, or in addition to, the standard features provided with the Switched Access Services. They are provided as either Common Switching or Transport Termination options.

**6.3.1 COMMON SWITCHING OPTIONAL FEATURES**

A. Call Denial On Line Or Hunt Group

This option allows for the screening of terminating calls within the LATA, and for the completion only of calls to 411, 611, 911, 8XX, 555-1212 and a Company specified set of NXXs within the Company local exchange calling area of the dial tone office in which the arrangement is provided. All other "toll" calls are routed to a reorder tone or recorded announcement. This feature is provided in all Company electronic end offices and, where available, in electromechanical end offices. It is available with Feature Group A.

B. Service Code Denial On Line Or Hunt Group

This option allows for the screening of terminating calls within the LATA, and for disallowing completion of calls to 0-, 555 and N11 (e.g., 411, 611 and 911). This feature is provided where available in all Company electronic end offices and electromechanical end offices. It is available with Feature Group A.

C. Hunt Group Arrangement

This option provides the ability to sequentially access one of two or more line side connections in the originating direction, when the access code of the line group is dialed. This feature is provided in all Company end offices. It is available with Feature Group A. Resold and non-resold services cannot be mixed in the same hunt group arrangement.

D. Uniform Call Distribution Arrangement

This option provides a type of multiline hunting arrangement which provides for an even distribution of calls among the available lines in a hunt group. Where available, this feature is provided in Company electronic end offices only. It is available with Feature Group A.

**NOTICE**  
**THE INFORMATION CONTAINED IN THIS DOCUMENT IS SUBJECT TO CHANGE.**

**Qwest Corporation**  
**Access Service**  
**Catalog No. 1**

**SECTION 6**  
Page 63  
Release 1  
Effective: 8-1-05

**NORTHERN IDAHO**  
Issued: 7-1-05

**6. SWITCHED ACCESS SERVICE**

**6.3 COMMON SWITCHING AND TRANSPORT TERMINATION OPTIONAL FEATURES**

**6.3.1 COMMON SWITCHING OPTIONAL FEATURES (Cont'd)**

**E. Nonhunting Number For Use With Hunt Group Or Uniform Call Distribution Arrangement**

This option provides an arrangement for an individual line within a multiline hunt or uniform call distribution group that provides access to that line within the hunt or uniform call distribution group when it is idle or provides busy tone when it is busy, when the nonhunting number is dialed. Where available, this feature is provided in Company electronic end offices only. It is available with Feature Group A.

**F. Automatic Number Identification (ANI)**

1. This option provides the automatic transmission of a three, seven or ten digit number and information digits to the customer's premises for calls originating in the LATA, to identify the calling station. The three, seven or ten digit numbers will contain the following information: three digit, NPA only; seven digit, NXX-XXXX; ten digit, NPA+NXX-XXXX. The ANI feature is an end office software function which is associated on a call-by-call basis with (1) trunk groups routed directly between an end office and a customer's premises via DTT or, where technically feasible, with (2) TST trunk groups between an end office and an access tandem, and trunk groups between an access tandem and customer's premises.
2. The seven digit ANI telephone number is available with Feature Group B, where provided, and Feature Group C. The seven digit ANI telephone number (C) is available with 900 Access Service. With these Feature Groups and 900 Access Service, ANI will be provided only with DTT. ANI will be transmitted on all calls except those originating from four or eight party lines, pay telephones using Feature Group B, when the end user has dialed 0- for operator assistance or when an ANI failure has occurred.

**NOTICE**  
**THE INFORMATION CONTAINED IN THIS DOCUMENT IS SUBJECT TO CHANGE.**

**Qwest Corporation**  
**Access Service**  
**Catalog No. 1**

**SECTION 6**  
Page 64  
Release 1  
Effective: 8-1-05

**NORTHERN IDAHO**  
Issued: 7-1-05

**6. SWITCHED ACCESS SERVICE**

**6.3 COMMON SWITCHING AND TRANSPORT TERMINATION OPTIONAL FEATURES**

**6.3.1 COMMON SWITCHING OPTIONAL FEATURES**

F. Automatic Number Identification (ANI) (Cont'd)

3. The ten digit ANI telephone number is only available with Feature Group D, including 800 DB Access Service and 900 Access Service provisioned as Feature Group D. The ten digit ANI telephone number consists of the Numbering Plan Area (NPA) plus the seven digit ANI telephone number. The ten digit ANI telephone number will be transmitted on all calls except those identified as four or eight party lines or when the end user has dialed 0- for operator assistance, in which case only the NPA will be transmitted (in addition to the information digits).
4. When 800 DB Access Service is ordered, the ten digit ANI telephone number will be transmitted on all calls except those where ANI cannot be provided as stated above or from end offices not equipped to provide ANI. In these instances, only the three digit NPA and the information digits described in the LATA Switching Systems Generic Requirements (LSSGR), Technical Reference PUB FR-64, if applicable, will be transmitted.
5. With Feature Group C, ANI is provided from end offices at which Company recording for end user billing is not provided, or where it is not required. It is not provided from end offices for which the Company needs to forward ANI to its recording equipment.
6. Technical specifications are delineated in Technical Reference PUB TR-NPL-000175 and PUB TR-NPL-000258.
7. Where ANI cannot be provided, e.g., on calls from four and eight party services, information digits will be provided to the customer.
8. The information digits identify: (1) telephone number is the station billing number - no special treatment required; (2) multiparty line telephone number is a four or eight party line and cannot be identified number must be obtained via an operator or in some other manner; (3) ANI failure has occurred in the end office switch which prevents identification of calling telephone number - must be obtained by operator or in some other manner; (4) hotel/motel originated call which requires room number identification; (5) coinless station, hospital, inmate, etc., call which requires special screening or handling by the customer; or (6) call is an Automatic Identified Outward Dialed (AIOD) call from customer premises equipment. The ANI telephone number is the listed telephone number of the customer and is not the telephone number of the calling party. These ANI information digits are available with Feature Group B, where provided, Feature Group C and Feature Group D.

**NOTICE**  
**THE INFORMATION CONTAINED IN THIS DOCUMENT IS SUBJECT TO CHANGE.**

**Qwest Corporation**  
**Access Service**  
**Catalog No. 1**

**SECTION 6**  
Page 65  
Release 1  
Effective: 8-1-05

**NORTHERN IDAHO**  
Issued: 7-1-05

**6. SWITCHED ACCESS SERVICE**

**6.3 COMMON SWITCHING AND TRANSPORT TERMINATION OPTIONAL FEATURES**

**6.3.1 COMMON SWITCHING OPTIONAL FEATURES**

**F. Automatic Number Identification (ANI) (Cont'd)**

9. Charge Number is the SS7 Out of Band Signaling equivalent of the ten digit ANI telephone number. Charge Number is the automatic transmission of the ten digit billing number of the calling station and the originating line information when a FGD trunk group is provisioned with SS7 Out of Band Signaling. Charge Number is provided when the customer requests the ANI optional feature on FGD trunk groups provisioned with SS7 Out of Band Signaling.
10. ANI information and Charge Number information are provided based on the following requirements:
  - The telephone number and billing information may be used for billing and collection, routing, screening, and completion of the originating subscriber's call or transaction, or for services directly related to the originating subscriber's call or transaction;
  - The ANI information shall not be reused or resold without first (A) notifying the originating subscriber and (B) obtaining the affirmative consent of such subscriber for such reuse or resale; and
  - ANI information shall not be disclosed, except as permitted by (1) and (2), above, for any purpose other than (i) performing the services or transactions that are the subject of the originating subscriber's call, (ii) ensuring network performance security, and the effectiveness of call delivery, (iii) compiling, using and disclosing aggregate information, and (iv) complying with applicable law or legal process.

**G. Up To 7 Digit Outpulsing Of Access Digits To Customer**

This option provides for the end office capability of providing up to 7 digits of the uniform access code (950-XXXX or 1+950-XXXX) to the customer's premises. The customer can request that only some of the digits in the access code be forwarded. The access code digits would be provided to the customer's premises using multifrequency signaling, and transmission of the digits would precede the forwarding of ANI if that feature were provided. It is available with Feature Group B.

**NOTICE**  
**THE INFORMATION CONTAINED IN THIS DOCUMENT IS SUBJECT TO CHANGE.**

**Qwest Corporation**  
**Access Service**  
**Catalog No. 1**

**SECTION 6**  
Page 66  
Release 1  
Effective: 8-1-05

**NORTHERN IDAHO**  
Issued: 7-1-05

**6. SWITCHED ACCESS SERVICE**

**6.3 COMMON SWITCHING AND TRANSPORT TERMINATION OPTIONAL FEATURES**

**6.3.1 COMMON SWITCHING OPTIONAL FEATURES (Cont'd)**

H. Cut-Through

This option allows end users of the customer to reach the customer's premises by using the end of dialing digit (#). This option provides for connection of the call to the premises of the customer indicated by the 101XXXX code upon receipt of the end of dialing digit (#). The Company will not record any other dialed digits for these calls. This option is available with Feature Group D.

I. Delay Dial Start-Pulsing Signaling

This option provides a method of indicating to the near end trunk circuit readiness to accept address signaling information by the far end trunk circuit. Delay dial is often referred to as an off-hook, on-hook signaling sequence. The delay dial signal is the off-hook interval and the start-pulsing signal is the on-hook interval. With integrity check, the calling office will not outpulse until a delay dial (off-hook) signal followed by a start-pulsing (on-hook) signal has been identified at the calling office. This option is available with Feature Group C.

J. Immediate Dial Pulse Address Signaling

This option provides for the forwarding of dial pulses from the Company end office to the customer without the need of a start-pulsing signal from the customer. It is available with Feature Group C.

K. Dial Pulse Address Signaling

This trunkside option provides for the transmission of number information, e.g., called number, between the end office switching system and the customer's POT in either direction by means of direct current pulses. It is available with Feature Group C.

**NOTICE**  
**THE INFORMATION CONTAINED IN THIS DOCUMENT IS SUBJECT TO CHANGE.**

**Qwest Corporation**  
**Access Service**  
**Catalog No. 1**

**SECTION 6**  
Page 67  
Release 1  
Effective: 8-1-05

**NORTHERN IDAHO**  
Issued: 7-1-05

**6. SWITCHED ACCESS SERVICE**

**6.3 COMMON SWITCHING AND TRANSPORT TERMINATION OPTIONAL FEATURES**

**6.3.1 COMMON SWITCHING OPTIONAL FEATURES (Cont'd)**

L. Service Class Routing

This option provides the capability of directing originating traffic from an end office to a trunk group to a customer designated premises, based on the line class of service (e.g., coin, multiparty or hotel/motel), service prefix indicator (e.g., 00+, 00-, 0+, 0- or 1+) or service access code (e.g., 8XX or 900). A customer may direct all originating calls from an end office to a tandem trunk group to a single customer POT or multiple POTs when ordered with MPTS as referred to in 6.1.2.A.4.d., preceding, based on the line class of service, service prefix indicator or service access code. It is provided in suitably equipped end office or access tandem switches and is available with Feature Groups C and D based on technical limitations.

M. Alternate Traffic Routing

1. Multiple Customer Premises Alternate Routing without MPTS

This option provides the capability of directing originating traffic from an end office (or appropriately equipped access tandem) via a trunk group (the "high usage" group) to a customer designated premises until that group is fully loaded, and then delivering additional originating traffic (the "overflowing" traffic) from the same end office or access tandem to a different trunk group (via one or more intermediate high usage groups) to different customer designated premises until the originating traffic is directed to a final trunk group. The customer shall specify the last trunk CCS desired for the high usage group and each intermediate group(s). It is provided in suitably equipped end office or access tandem switches and is available with Feature Groups B, C and D. MPTS Alternate Routing is not available on FGD Service provisioned on a DTT Facility equipped with TSI.

2. Multiple Customer Premises Alternate Routing with MPTS

This option provides the capability of directing originating traffic from an end office via a direct trunk group (the high usage group) and deliver originating traffic (the overflowing traffic) from the same end office through the tandem to a tandem routed trunk group (the "final" group) to a customer designated POT. The tandem trunk group must be routed to the customer designated POT that is specified for the Tandem Sector of the originating end office. It is provided in suitably equipped end office or access tandem switches and is available with Feature Groups C and D.

**NOTICE**  
**THE INFORMATION CONTAINED IN THIS DOCUMENT IS SUBJECT TO CHANGE.**

**Qwest Corporation**  
**Access Service**  
**Catalog No. 1**

**SECTION 6**  
Page 68  
Release 1  
Effective: 8-1-05

**NORTHERN IDAHO**  
Issued: 7-1-05

**6. SWITCHED ACCESS SERVICE**

**6.3 COMMON SWITCHING AND TRANSPORT TERMINATION OPTIONAL FEATURES**

**6.3.1 COMMON SWITCHING OPTIONAL FEATURES**

M.2. (Cont'd)

Alternate traffic routing through the tandem to a multiple customer POT is not an option with MPTS. A customer may not overflow tandem traffic from one customer designated POT to a second customer designated POT.

3. End Office Alternate Routing When Ordered in Trunks

This option provides an alternate routing arrangement for customers who order in trunks and have access for a particular Feature Group to an end office via two routes: one route via an access tandem and one direct route. The feature allows the customer's originating traffic from the end office to be offered first to the direct trunk group and then overflow to the access tandem group. It is provided in suitably equipped end offices and is available with Feature Groups B, C and D.

4. End Office Alternate Routing to a Customer-Provided Tandem Premises

This option provides an alternate routing arrangement for customers who order in trunks and have access to an end office via two routes: one route equipped with Tandem Signaling Information (TSI) via a customer-provided tandem premises and one direct route without TSI. The option allows FGD originating traffic from an end office to be offered first to the direct trunk group and then overflow to the customer-provided tandem group. When the customer selects this option the customer may not have for the same end office an alternate route to a Company access tandem. This option is provided in suitably equipped end offices and is available with FGD Service only.

N. Trunk Access Limitation

This option provides for the routing of originating 900 service calls to a specified number of transmission paths in a trunk group, in order to limit (choke) the completion of such traffic to the customer. Calls to the designated service which could not be completed over the subset of transmission paths in the trunk group, i.e., the choked calls, would be routed to reorder tone. It is provided in all Company electronic end offices and where available in electromechanical end offices. It is available with Feature Groups C and D.

**NOTICE**  
**THE INFORMATION CONTAINED IN THIS DOCUMENT IS SUBJECT TO CHANGE.**

**Qwest Corporation**  
**Access Service**  
**Catalog No. 1**

**SECTION 6**  
Page 69  
Release 1  
Effective: 8-1-05

**NORTHERN IDAHO**  
Issued: 7-1-05

Effective: 8-1-05

**6. SWITCHED ACCESS SERVICE**

**6.3 COMMON SWITCHING AND TRANSPORT TERMINATION OPTIONAL FEATURES**

**6.3.1 COMMON SWITCHING OPTIONAL FEATURES (Cont'd)**

**O. WATS Access Service (WATS)**

1. At the option of the customer, WATS Access Service may be provided at Company designated end office switches, referred to as WATS Serving Office(s)(WSO). WATS Access Service is provided in conjunction with Feature Groups C or D Switched Access Service and a WATS access line. The WATS access line as described in 5.2, preceding, is required to connect the WSO to the end user's premises.
2. WATS access lines are available for intrastate service as a Shared WATS access line or a dual jurisdiction WATS access line as set forth in 5.2, preceding.
3. For WATS Access Service provided on a dual jurisdiction basis; i.e., interstate and intrastate, the following information applies:
  - a. The WSO is capable of performing the necessary routing, screening and recording functions for 800/800-type Service, Outward WATS and similar services and is provided only for use at the closed end of such services.
  - b. WATS Access Service can be arranged for originating-only, terminating-only or two-way calling depending on the specific arrangement employed. Dial pulse or dual tone multifrequency address signaling and either loop start or ground start supervisory signaling is used to work with the WATS access line ordered subject to the terms and conditions of the Company's Interstate Access Service Tariff F.C.C. No. 1.
  - c. WATS Access Service options are available in conjunction with WATS Access Service. These options are provided in Company designated WSO(s) and are available for use with WATS Access Service only. WATS Access Service options are available in conjunction with Feature Groups C and D as specified herein. A brief description of each WATS Access Service option is described following.

**NOTICE**  
**THE INFORMATION CONTAINED IN THIS DOCUMENT IS SUBJECT TO CHANGE.**

**Qwest Corporation**  
**Access Service**  
**Catalog No. 1**

**SECTION 6**  
Page 70  
Release 1  
Effective: 8-1-05

**NORTHERN IDAHO**  
Issued: 7-1-05

Effective: 8-1-05

**6. SWITCHED ACCESS SERVICE**

**6.3 COMMON SWITCHING AND TRANSPORT TERMINATION OPTIONAL FEATURES**

**6.3.1 COMMON SWITCHING OPTIONAL FEATURES**

O.3.c. (Cont'd)

(1) Band Advance

This option, which is provided in association with two or more WATS Access Line groups, provides for the automatic overflow of terminating calls to a WATS Access Line group, when that group has exceeded its call capacity, to another WATS Access Line group with a band designation equal to or greater than that of the overflowing WATS Access Line group. Band Advance does not provide for call overflow from a group with a higher band designation to one with a lower one.

(2) Hunt Group

This option provides the ability to access sequentially one of two or more WATS Access Lines in the terminating direction, when the hunting number of the WATS Access Line group is forwarded from the customer to the Company.

(3) Uniform Call Distribution

This option provides a type of multiline hunting which provides for an even distribution of terminating calls among the available WATS Access Lines in the hunt group.

(4) Nonhunting Number for Use with Hunt Group or Uniform Call Distribution

This option provides for an individual WATS Access Line that is within a multiline hunt or uniform call distribution group, to provide access to the WATS Access Service within the hunt or uniform call distribution group when it is idle or provides busy tone when it is busy, when the nonhunting number is dialed.

**NOTICE**  
**THE INFORMATION CONTAINED IN THIS DOCUMENT IS SUBJECT TO CHANGE.**

**Qwest Corporation**  
**Access Service**  
**Catalog No. 1**

**SECTION 6**  
Page 71  
Release 1  
Effective: 8-1-05

**NORTHERN IDAHO**  
Issued: 7-1-05

**6. SWITCHED ACCESS SERVICE**

**6.3 COMMON SWITCHING AND TRANSPORT TERMINATION OPTIONAL FEATURES**

**6.3.1 COMMON SWITCHING OPTIONAL FEATURES (Cont'd)**

**P. Feature Group A InterLATA Toll Denial**

This option provides for the screening of all calls on terminating lines and for the completion only of calls to 411, 611, 911, 8XX, 555-1212, Local Information Delivery Services and 0+ or 1+ intraLATA. All interLATA calls, 950-XXXX and 10XXX or 101XXXX are routed to a recorded announcement.

This feature is provided in all Company end offices where technically available. It is available with Feature Group A. This feature does not affect calls placed on originating FGA lines.

Customers requesting FGA line(s) without the InterLATA Toll Denial option, will be responsible for InterLATA calls recorded on FGA line(s).

**Q. Signaling System Seven (SS7) Out Of Band Signaling**

This option provides SS7 Out of Band Signaling on a FGD transmission path group. This option provides the customer the ability to use Out of Band Signaling to set up trunks on a per call basis. CCSAC Service as described in SECTION 65. following, is required between the customer's Signaling Point of Interface (SPOI) and the Company's Signal Transfer Point (STP) for SS7 Out of Band Signaling in each LATA.

SS7 Out of Band Signaling provides the automatic transmission of the following parameters:

- Access Transport Parameter (ATP) provides automatic transmission of information from the originating calling location through the Common Channel Signaling Network. Information supplied using ATP may consist of one or more of the following: Called Party Subaddress; Calling Party Subaddress; High and Low Layer Compatibility and Compatibility Checking by the called party's equipment. ATP is available when Feature Group D Service is equipped with SS7 Out of Band Signaling and Clear Channel Capability.

**NOTICE**  
**THE INFORMATION CONTAINED IN THIS DOCUMENT IS SUBJECT TO CHANGE.**

**Qwest Corporation**  
**Access Service**  
**Catalog No. 1**

**SECTION 6**  
Page 72  
Release 1  
Effective: 8-1-05

**NORTHERN IDAHO**  
Issued: 7-1-05

**6. SWITCHED ACCESS SERVICE**

**6.3 COMMON SWITCHING AND TRANSPORT TERMINATION OPTIONAL FEATURES**

**6.3.1 COMMON SWITCHING OPTIONAL FEATURES**

**Q. Signaling System Seven (SS7) Out Of Band Signaling (Cont'd)**

- Calling Party Number (CPN) is the automatic transmission of the calling party's ten digit telephone number to the customer's premises for calls originating in the LATA. The ten digit number consists of the Numbering Plan Area (NPA) plus the seven digit telephone number. The Company will automatically transmit CPN with SS7 Out of Band Signaling in those offices suitably equipped with the software that allows customers to elect to block their CPN information from being displayed to the called party. This software allows the customer to block their CPN on a per call basis, and transmits a "privacy indicator" as part of the CPN information.
- Charge Number is the SS7 Out of Band Signaling equivalent of the ten-digit ANI telephone number. Charge Number is the automatic transmission of the ten-digit billing number of the calling station and the originating line information when a FGD trunk group is provisioned with SS7 Out of Band Signaling. Charge Number is provided when the customer requests the ANI optional feature on FGD trunk groups provisioned with SS7 Out of Band Signaling.

Charge Number information is provided based on the following requirements:

- (1) the telephone number and billing information may be used for billing and collection, routing, screening, and completion of the originating subscriber's call or transaction, or for services directly related to the originating subscriber's call or transaction;
  - (2) the Charge Number information shall not be reused or resold without first (A) notifying the originating subscriber and (B) obtaining the affirmative consent of such subscriber for such reuse or resale; and
  - (3) Charge Number information shall not be disclosed, except as permitted by (1) and (2), above, for any purpose other than (i) performing the services or transactions that are the subject of the originating subscriber's call, (ii) ensuring network performance security, and the effectiveness of call delivery, (iii) compiling, using and disclosing aggregate information, and (iv) complying with applicable law or legal process.
- Carrier Selection Parameters (CSP) is the automatic transmission of a signaling indicator which signifies to the customer that the call being processed originated from a presubscribed line or by dialing the 101XXXX code.

**NOTICE**  
**THE INFORMATION CONTAINED IN THIS DOCUMENT IS SUBJECT TO CHANGE.**

**Qwest Corporation**  
**Access Service**  
**Catalog No. 1**

**SECTION 6**  
Page 73  
Release 1  
Effective: 8-1-05

**NORTHERN IDAHO**  
Issued: 7-1-05

**6. SWITCHED ACCESS SERVICE**

**6.3 COMMON SWITCHING AND TRANSPORT TERMINATION OPTIONAL FEATURES**

**6.3.1 COMMON SWITCHING OPTIONAL FEATURES**

**Q. Signaling System Seven (SS7) Out Of Band Signaling (Cont'd)**

The technical specifications for ATP, CPN and CSP parameters are described in Technical Reference PUB TR-TSV-000905, GR-394-CORE and in Qwest Corporation Technical Reference PUB 77342.

SS7 Out of Band Signaling is a nonchargeable optional feature. There is a nonrecurring charge associated with the rearrangement of FGD Service trunk groups with multifrequency (MF) signaling to SS7 Out of Band Signaling trunk group(s). The description and application of the rearrangement charges from MF to SS7 Out of Band Signaling on FGD Service are described in 6.7.1, following.

**R. Clear Channel Capability**

Clear Channel Capability (CCC) is the ability to send any combination of ones (marks) and zeros (spaces) in the 192 information bits of each frame. This permits 24 DSO-64 kbps services or 1.536 Mbps of customer information on the 1.544 Mbps line rate.

Bipolar Eight Zero Substitution (B8ZS) line code conformity is required. The B8ZS line code is described in Technical Reference PUB TR-NWT-000938.

CCC is available on FGD Service when the trunkside service is equipped with SS7 Out of Band Signaling and Interface Group 6 or 9 on separate trunk(s) in suitably equipped digital Company end offices or access tandems. CCC may be utilized in conjunction with 800 DB Access Service for transmission of 8XX data traffic where technically feasible.

CCC equipped trunkside service requires a specific traffic type (i.e., CCC Originating and/or CCC Terminating) as set forth in 6.1.1, preceding.

The description and application of rates and charges for CCC are set forth in 6.7.1, following.

**NOTICE**  
**THE INFORMATION CONTAINED IN THIS DOCUMENT IS SUBJECT TO CHANGE.**

**Qwest Corporation**  
**Access Service**  
**Catalog No. 1**

**SECTION 6**  
Page 74  
Release 1  
Effective: 8-1-05

**NORTHERN IDAHO**  
Issued: 7-1-05

**6. SWITCHED ACCESS SERVICE**

**6.3 COMMON SWITCHING AND TRANSPORT TERMINATION OPTIONAL FEATURES (Cont'd)**

**6.3.2 TRANSPORT TERMINATION OPTIONAL FEATURES**

A. Operator Trunk-Coin, Non-Coin, or Combined Coin and Non-Coin

This option may be ordered to provide coin, non-coin, or combined coin and non-coin operation. It is available only with Feature Groups C and D. Non-coin trunks are provided in Company electronic and electromechanical end offices. Coin and combined coin and non-coin trunks are provided only at Company electronic end offices and other Company end offices where equipment is available. This option is provided as a trunk type of Transport Termination and is not available with SS7 Out of Band Signaling.

1. Coin:

- a. This arrangement provides for initial coin return control and routing of 00+, 00-, 0+, 0- or 1+ prefixed originating coin calls requiring operator assistance to the customer's premises. Because operator assisted coin calling traffic is routed over a trunk group dedicated to operator assisted calls, this arrangement is only provided in association with the Service Class Routing option.
- b. The operator assistance coin calling arrangement is also normally ordered by the customer in conjunction with the ANI optional feature, since the preponderance of trunk groups equipped with this arrangement will be terminated in the customer's operator service positions, rather than in the customer's manual cord boards.

2. Non-Coin:

- a. This arrangement provides for the routing of 00+, 00-, 0+, 0- or 1+ prefixed originating non-coin calls requiring operator assistance to the customer's premises. Because operator assisted non-coin calling traffic is routed over a trunk group dedicated to operator assisted calls, this arrangement is only provided in association with the Service Class Routing option.

**NOTICE**  
**THE INFORMATION CONTAINED IN THIS DOCUMENT IS SUBJECT TO CHANGE.**

**Qwest Corporation**  
**Access Service**  
**Catalog No. 1**

**SECTION 6**  
Page 75  
Release 1  
Effective: 8-1-05

**NORTHERN IDAHO**  
Issued: 7-1-05

**6. SWITCHED ACCESS SERVICE**

**6.3 COMMON SWITCHING AND TRANSPORT TERMINATION OPTIONAL FEATURES**

**6.3.2 TRANSPORT TERMINATION OPTIONAL FEATURES**

A.2. (Cont'd)

- b. The operator assistance non-coin calling arrangement is also normally ordered by the customer in conjunction with the ANI optional feature, since the preponderance of trunk groups equipped with this arrangement will be terminated in the customer's operator service positions, rather than in the customer's manual cord boards. When so equipped, the ANI feature provides for the forwarding of information digits which identify that the call has originated from a hotel or motel, and whether room number identification is required, or that special screening is required, e.g., for coinless pay telephones, dormitory or inmate stations, or other screening arrangements agreed to between the customer and the Company.

3. Combined Coin and Non-Coin:

- a. This arrangement provides for initial coin return control and routing of 00+, 00-, 0+, 0- or 1+ prefixed originating operator assisted coin and non-coin calls requiring operator assistance to the customer's premises. Because operator assisted coin and non-coin calling traffic is routed over a trunk group dedicated to operator assisted calls, this arrangement is only provided in association with the Service Class Routing option.
- b. This arrangement is normally ordered by the customer in conjunction with the ANI optional feature, since the preponderance of trunk groups equipped with this arrangement will be terminated in the customer's operator services systems, rather than in the customer's manual cord boards. When so equipped, the ANI optional features provide for the forwarding of information digits which identify that the call has originated from a hotel or motel, and whether room number identification is required, or that special screening is required, e.g., for coinless pay telephones, dormitory or inmate stations, or other screening arrangements agreed to between the customer and the Company.

B. Operator Trunk - Full Feature

This option provides the operator functions available in the end office to the customer's operator. These functions are (1) Operator Released, (2) Operator Attached, (3) Coin Collect, (4) Coin Return, and (5) Ringback. It is available with Feature Group D and is provided as a trunk type for Transport Termination. This option is not available with SS7 Out of Band Signaling.

**NOTICE**  
**THE INFORMATION CONTAINED IN THIS DOCUMENT IS SUBJECT TO CHANGE.**

**Qwest Corporation**  
**Access Service**  
**Catalog No. 1**

**SECTION 6**  
Page 76  
Release 1  
Effective: 8-1-05

**NORTHERN IDAHO**  
Issued: 7-1-05

**6. SWITCHED ACCESS SERVICE**

**6.4 TRANSMISSION SPECIFICATIONS**

- A. Each Switched Access Service transmission path is provided with standard transmission parameter limits. The standard for a particular transmission path is dependent on the Switched Access Service, the Interface Group and whether the service is directly routed to an end office or routed to the access tandem or a customer-provided tandem utilizing tandem switching functions. The available transmission parameter limits are set forth in Technical Reference PUB GR-334-CORE and associated addenda. Data transmission parameter limits are also provided with each Switched Access Service transmission path. The Company will, upon notification by the customer that the data parameters set forth in Technical Reference PUB GR-334-CORE and associated addenda are not being met, conduct tests independently or in cooperation with the customer, and take any necessary action to ensure that the data parameters are met.
- B. The Company will maintain existing transmission parameter limits on functioning service configurations installed prior to January 1, 1984, except that service configurations having performance specifications exceeding the standards listed in this provision will be maintained at performance levels specified in Technical Reference PUB GR-334-CORE and associated addenda.
- C. The transmission parameter limits contained in this section are Immediate Action Limits (IAL). Acceptance Limits (AL) are set forth in Technical Reference PUB GR-334-CORE and associated addenda. This technical reference also provides the basis for determining Switched Access Service maintenance limits.
- D. Transmission specifications for SS7 Out of Band Signaling are delineated in Technical Reference PUB GR-394-CORE, TR-TSV-000905 and in Qwest Corporation Technical Reference PUB 77342.
- E. Transmission specifications and error performance parameters for DS1 level digital transmission on FGD Service equipped with Clear Channel Capability are delineated in Technical Reference PUB GR-334-CORE.

When Switched Access FGD Service is provided via a customer-provided tandem premises, the technical transmission specifications for the customer-provided tandem must conform with the technical specifications established for Company access tandem switches. These specifications are described in Technical Reference PUB FR-64 and GR-334-CORE. For FGD trunks with tandem signaling information, the transmission parameter limits and interface combinations are delineated in Bellcore Generic Requirements GR-334-CORE.

**NOTICE**  
**THE INFORMATION CONTAINED IN THIS DOCUMENT IS SUBJECT TO CHANGE.**

**Qwest Corporation**  
**Access Service**  
**Catalog No. 1**

**SECTION 6**  
Page 77  
Release 1  
Effective: 8-1-05

**NORTHERN IDAHO**  
Issued: 7-1-05

Effective: 8-1-05

---

**6. SWITCHED ACCESS SERVICE**

**6.5 OBLIGATIONS OF THE COMPANY**

In addition to the obligations of the Company set forth in Section 2, preceding, the Company has certain other obligations pertaining only to the provision of Switched Access Service. These obligations are as follows:

**6.5.1 NETWORK MANAGEMENT**

The Company will administer its network to ensure the provision of acceptable service levels to all telecommunications users of the Company's network services.

Generally, service levels are considered acceptable only when both end users and customers are able to establish connections with little or no delay encountered within the Company network. The Company maintains the right to apply protective controls, i.e., those actions, such as call gapping, which selectively cancel the completion of traffic, over any traffic carried over its network, including that associated with a customer's Switched Access Service. Generally, such protective measures would only be taken as a result of occurrences such as failure or overload of Company or customer facilities, natural disasters, mass calling or national security demands. In the event that the protective controls applied by the Company result in the complete loss of service by the customer, the customer will be granted a Credit Allowance for Service Interruption as set forth in 2.4.5.B.2., preceding.

**NOTICE**  
**THE INFORMATION CONTAINED IN THIS DOCUMENT IS SUBJECT TO CHANGE.**

**Qwest Corporation**  
**Access Service**  
**Catalog No. 1**

**SECTION 6**  
Page 78  
Release 1  
Effective: 8-1-05

**NORTHERN IDAHO**  
Issued: 7-1-05

Effective: 8-1-05

**6. SWITCHED ACCESS SERVICE**

**6.5 OBLIGATIONS OF THE COMPANY (Cont'd)**

**6.5.2 DESIGN AND TRAFFIC ROUTING OF SWITCHED ACCESS SERVICE**

When ordering Switched Access Service, the customer shall specify on the order for service the Entrance Facility, the desired interoffice transport, (i.e., DTT or TST), the number of lines, trunks, or BHMC and the desired directionality (i.e., one-way, two-way). When the customer orders facilities, routing, directionality or optional features different from that determined to be available by the Company, the Company will work cooperatively with the customer in determining an acceptable configuration based on available facilities, equipment and the Company routing plans. Rates and charges for Switched Transport, as set forth in 6.8, following, will be applied based on the transport provisioned at the time the order is completed. For example, if DTT is requested but facilities are not available and the customer accepts TST, the rates for TST shall apply until such time that DTT is provided.

**6.5.3 DS1 RECORDS ASSIGNMENT**

When the customer initially orders a DS3 EF in conjunction with TST or a DS3 EF with DS3 DTT facilities to a Company Hub, access tandem or end office, the Company will provide to the customer, the appropriate DS1 facility record necessary for the customer to identify circuit facility assignment (CFA). On subsequent orders utilizing existing DS3 EF or DS3 DTT facilities, the Company will assign the DS1 facility to the DS3 EF or DS3 DTT facility as directed by the customer's order.

**6.5.4 MULTIPLEXING**

The Company will provide multiplexing equipment at a location determined by the Company as part of its overall network design when the conditions exist as set forth in 6.1.2, preceding.

**NOTICE**  
**THE INFORMATION CONTAINED IN THIS DOCUMENT IS SUBJECT TO CHANGE.**

**Qwest Corporation**  
**Access Service**  
**Catalog No. 1**

**SECTION 6**  
Page 79  
Release 1  
Effective: 8-1-05

**NORTHERN IDAHO**  
Issued: 7-1-05

---

**6. SWITCHED ACCESS SERVICE**

**6.5 OBLIGATIONS OF THE COMPANY (Cont'd)**

**6.5.5 PROVISION OF SERVICE PERFORMANCE DATA**

Subject to availability, end-to-end service performance data available to the Company through its own service evaluation routines, may also be made available to the customer based on previously arranged intervals and format. These data provide information on overall end-to-end call completion and noncompletion performance, e.g., customer equipment blockage, failure results and transmission performance. These data do not include service performance data which are provided under other sections, e.g., testing service results. If data are to be provided in other than paper format, the charges for such exchange will be determined on an individual case basis.

**6.5.6 TRUNK GROUP MEASUREMENT REPORTS**

Subject to availability, the Company will make available trunk group data in the form of usage in CCS, peg count and overflow, to the customer based on previously agreed to intervals. Trunk group measurement reports will be available for Switched Access Service and WATS Access Service at no charge to the customer.

**6.5.7 DETERMINATION OF NUMBER OF TRANSMISSION PATHS**

DS1 and DS3 Entrance Facilities and DTT facilities requested by the customer are solely transport facilities capable of 24 and 672 channels, respectively, and do not reflect the actual switching capacity in the SWC, end office, access tandem or Company Hub. The actual number of transmission paths provided will be based on the customer's line or trunk request. Subsequent assignment will be based on switching equipment available.

For Lineside or Trunkside Switched Access Service, which is ordered on a per line or per trunk basis, the customer specifies the number of transmission paths in the order for service. For Switched Access Service, which is ordered on a BHMC basis utilizing TST, the Company will determine the number of Switched Access Service transmission paths to be provided from the SWC of the customer's premises to Company end offices via the access tandem. The number of transmission paths will be developed using the total BHMC by type (as described in 6.1.1, preceding) ordered. The total BHMCs by type, for each end office to which the customer has ordered service, will be converted to transmission paths using standard Company traffic engineering methods. The number of transmission paths provided shall be the number required based on the use of access tandem switches and end office switches.

**NOTICE**  
**THE INFORMATION CONTAINED IN THIS DOCUMENT IS SUBJECT TO CHANGE.**

**Qwest Corporation**  
**Access Service**  
**Catalog No. 1**

**SECTION 6**  
Page 80  
Release 1  
Effective: 8-1-05

**NORTHERN IDAHO**  
Issued: 7-1-05

**6. SWITCHED ACCESS SERVICE**

**6.5 OBLIGATIONS OF THE COMPANY (Cont'd)**

**6.5.8 DETERMINATION OF NUMBER OF END OFFICE TRANSPORT TERMINATIONS**

For analog entry switches, a termination will be provided for each Feature Group line or trunk requested. For digital entry switches, an equivalent termination will be provided for each Feature Group line or trunk requested.

**6.5.9 DESIGN BLOCKING PROBABILITY**

The Company will design and monitor the facilities used in the provision of Switched Access Service to meet the blocking probability criteria as set forth in A. through E., following.

- A. For Feature Groups A and B, no design blocking criteria apply.
- B. For Feature Group C, the design blocking objective will be no greater than one percent (.01) between the POT at the customer's premises and the first point of switching when traffic is directly routed without an alternate route. Standard traffic engineering methods will be used by the Company to determine the number of transmission paths required to achieve this level of blocking.
- C. For Feature Group D, the design blocking objective for the final group will be no greater than one percent (.01) between the POT at the customer's premises and the end office switch, whether the traffic is directly routed without an alternate route or routed via an access tandem. Standard traffic engineering methods as set forth in reference document Special Report SR-TAP-000191, Trunk Traffic Engineering Concepts and Applications, will be used by the Company to determine the number of transmission paths required to achieve this level of blocking.

**NOTICE**  
**THE INFORMATION CONTAINED IN THIS DOCUMENT IS SUBJECT TO CHANGE.**

**Qwest Corporation**  
**Access Service**  
**Catalog No. 1**

**SECTION 6**  
Page 81  
Release 1  
Effective: 8-1-05

**NORTHERN IDAHO**  
Issued: 7-1-05

Effective: 8-1-05

**6. SWITCHED ACCESS SERVICE**

**6.5 OBLIGATIONS OF THE COMPANY**

**6.5.9 DESIGN BLOCKING PROBABILITY (Cont'd)**

- D. The design blocking criteria for 800 DB Access Service and 900 Access Service will be equivalent to the design blocking criteria of the Feature Group(s) that they are provisioned as except under media stimulation when use of protective controls may be utilized to ensure the provisioning of acceptable service levels to all telecommunications users of the Company's network services.
- E. The Company will perform routine measurement functions for the capacity ordered, whether ordered in trunks or BHMCs, in accordance with Company design blocking criteria to assure that an adequate number of transmission paths are in service. The Company will recommend that additional capacity (i.e., BHMC or trunks) be ordered by the customer when additional paths are required to reduce the measured blocking to the designed blocking level. Where design blocking criteria apply, the design blocking objective is assumed to have been met if the routine measurements show that the measured blocking does not exceed the thresholds listed in the following tables.

**NOTICE**  
**THE INFORMATION CONTAINED IN THIS DOCUMENT IS SUBJECT TO CHANGE.**

**Qwest Corporation**  
**Access Service**  
**Catalog No. 1**

**SECTION 6**  
Page 82  
Release 1  
Effective: 8-1-05

**NORTHERN IDAHO**  
Issued: 7-1-05

**6. SWITCHED ACCESS SERVICE**

**6.5 OBLIGATIONS OF THE COMPANY**  
**6.5.9 DESIGN BLOCKING PROBABILITY**  
E. (Cont'd)

1. For transmission paths carrying only first routed traffic directly between an end office and customer's premises without an alternate route, and for paths carrying only overflow traffic, the measured blocking thresholds are as follows:

NUMBER OF TRANSMISSION PATHS PER TRUNK GROUP	MEASURED BLOCKING THRESHOLDS IN THE TIME CONSISTENT BUSY HOUR FOR THE NUMBER OF MEASUREMENTS PER TRUNK GROUP			
	15-20	11-14	7-10	3-6
	MEASURE- MENTS	MEASURE- MENTS	MEASURE- MENTS	MEASURE- MENTS
2	.070	.080	.090	.140
3	.050	.060	.070	.090
4	.050	.060	.070	.080
5-6	.040	.050	.060	.070
7 or more	.030	.035	.040	.060

2. For transmission paths carrying first routed traffic between an end office and customer's premises via an access tandem, the measured blocking thresholds are as follows:

NUMBER OF TRANSMISSION PATHS PER TRUNK GROUP	MEASURED BLOCKING THRESHOLDS IN THE TIME CONSISTENT BUSY HOUR FOR THE NUMBER OF MEASUREMENTS PER TRUNK GROUP			
	15-20	11-14	7-10	3-6
	MEASURE- MENTS	MEASURE- MENTS	MEASURE- MENTS	MEASURE- MENTS
2	.045	.055	.060	.095
3	.035	.040	.045	.060
4	.035	.040	.045	.055
5-6	.025	.035	.040	.045
7 or more	.020	.025	.030	.040

**NOTICE**  
**THE INFORMATION CONTAINED IN THIS DOCUMENT IS SUBJECT TO CHANGE.**

**Qwest Corporation**  
**Access Service**  
**Catalog No. 1**

**SECTION 6**  
Page 83  
Release 1  
Effective: 8-1-05

.1  
**NORTHERN IDAHO**  
Issued: 7-1-05

---

**6. SWITCHED ACCESS SERVICE**

**6.6 OBLIGATIONS OF THE CUSTOMER**

In addition to the obligations of the customer set forth in Section 2, preceding, the customer has certain specific obligations pertaining to the use of Switched Access Service. These obligations are as follows:

**6.6.1 ORDERING REQUIREMENTS**

When ordering Switched Access Service, the customer shall specify on the order for service, the type and number of Entrance Facilities to terminate at the customer's SWC, the desired interoffice transport, (i.e., DTT or TST), the number of lines and/or trunks to be provisioned at an end office or access tandem and the desired directionality. The customer has the option of ordering Trunkside Switched Access Service in BHMC instead of trunks when TST is requested. If the customer orders Trunkside Switched Access Service in BHMC, the Company will determine the number of trunks as set forth in 6.5.7, preceding. For DTT, the customer must always order in trunks.

**NOTICE**  
**THE INFORMATION CONTAINED IN THIS DOCUMENT IS SUBJECT TO CHANGE.**

**Qwest Corporation**  
**Access Service**  
**Catalog No. 1**

**SECTION 6**  
Page 84  
Release 1  
Effective: 8-1-05

**NORTHERN IDAHO**  
Issued: 7-1-05

**6. SWITCHED ACCESS SERVICE**

**6.6 OBLIGATIONS OF THE CUSTOMER (Cont'd)**

**6.6.2 REPORT REQUIREMENTS**

Customers are responsible for providing the following reports to the Company, when applicable.

A. Jurisdictional Reports

When a customer orders Switched Access Service for both interstate and intrastate use, the customer is responsible for providing reports as set forth in 2.3.10, preceding. Charges will be apportioned in accordance with those reports. The method to be used for determining the intrastate charges is set forth in 2.3.11, preceding.

B. Code Screening Reports

When a customer orders service class routing or trunk access limitation arrangements, it must report the number of trunks and/or the appropriate codes to be instituted in each end office or access tandem switch, for each of the arrangements ordered.

C. 900 NXX Code Reports

When ordering 900 Access Service, the customer must report the appropriate NXX code(s) to be instituted in each Company end office at which the customer identification function is performed. The report must be updated by the customer each time a change is scheduled to occur (i.e., when a new code is to be added or an exiting code is to be deleted). Such updated reports shall be provided at least 60 calendar days prior to the effective date of the change in order to allow the Company sufficient time to implement the change.

D. Multiple POTs Tandem Sectorization Reports

When ordering MPTS, the customer must report the customer designated POTs for all subtending end offices served by an access tandem. The report shall be provided at the same time the Access Order is placed.

**NOTICE**  
**THE INFORMATION CONTAINED IN THIS DOCUMENT IS SUBJECT TO CHANGE.**

**Qwest Corporation**  
**Access Service**  
**Catalog No. 1**

**SECTION 6**  
Page 85  
Release 1  
Effective: 8-1-05

**NORTHERN IDAHO**  
Issued: 7-1-05

Effective: 8-1-05

---

**6. SWITCHED ACCESS SERVICE**

**6.6 OBLIGATIONS OF THE CUSTOMER (Cont'd)**

**6.6.3 SUPERVISORY SIGNALING**

The customer's facilities shall provide the necessary off-hook and on-hook answer and disconnect supervision.

**6.6.4 TRUNK GROUP MEASUREMENT REPORTS**

With the agreement of the customer, trunk group data in the form of usage in CCS, peg count and overflow for its end of all access trunk groups, where technologically feasible, will be made available to the Company. These data will be used to monitor trunk group utilization and service performance and will be based on previously arranged intervals and format.

**6.6.5 DESIGN OF SWITCHED ACCESS SERVICES**

When a customer orders Switched Access Service on a per-facility and/or per-trunk basis, it is the customer's responsibility to assure that sufficient access services have been ordered to handle its traffic.

**NOTICE**  
**THE INFORMATION CONTAINED IN THIS DOCUMENT IS SUBJECT TO CHANGE.**

**Qwest Corporation**  
**Access Service**  
**Catalog No. 1**

**SECTION 6**  
Page 86  
Release 1  
Effective: 8-1-05

**NORTHERN IDAHO**  
Issued: 7-1-05

---

**6. SWITCHED ACCESS SERVICE**

**6.7 RATE REGULATIONS**

This section contains the specific regulations governing the rates and charges that apply for Switched Access Service.

**6.7.1 DESCRIPTION AND APPLICATION OF RATES AND CHARGES**

There are three types of rates and charges that apply to Switched Access Service. These are monthly recurring rates, usage rates and nonrecurring charges. These rates and charges are applied differently to the various rate elements as set forth in C. and D., following.

**A. Monthly Rates**

Monthly rates are flat recurring rates that apply each month or fraction thereof that a specific rate element is provided. For billing purposes, each month is considered to have 30 days.

**B. Usage Rates**

Usage rates are rates that apply only when a specific rate element is used. These are applied on a per access minute, a per call or per query basis. Usage rates are accumulated over a monthly period.

**NOTICE**  
**THE INFORMATION CONTAINED IN THIS DOCUMENT IS SUBJECT TO CHANGE.**

**Qwest Corporation**  
**Access Service**  
**Catalog No. 1**

**SECTION 6**  
Page 87  
Release 1  
Effective: 8-1-05

**NORTHERN IDAHO**  
Issued: 7-1-05

Effective: 8-1-05

---

**6. SWITCHED ACCESS SERVICE**

**6.7 RATE REGULATIONS**

**6.7.1 DESCRIPTION AND APPLICATION OF RATES AND CHARGES (Cont'd)**

C. Nonrecurring Charges

Nonrecurring charges are one-time charges that apply for a specific work activity (i.e., installation or change to an existing service). The types of nonrecurring charges that apply for Switched Access Service are: installation of service, installation of optional features and service rearrangements. These charges are set forth in 6.8, following.

1. Installation of Service

Nonrecurring charges apply for the installation of the individual Feature Group line or trunk.

For Switched Access Service, which is ordered on a per line or on a per trunk basis, the charge is applied per line or trunk. For Switched Access Service, which is ordered on a BHMC basis, the charge is also applied on a per trunk basis but the charge applies only when the capacity ordered requires the installation of an additional trunk(s). These charges are assessed dependent on the Interface Group ordered for terminating the Switched Transport at the customer's POT. The Interface Group categories are: (1) Switched Access lines or trunks associated with Interface Groups 1 and 2, (2) Switched Access lines or trunks associated with Interface Group 6, or (3) Switched Access lines or trunks associated with Interface Group 9, per Access Order. Each of these categories has a first and each additional line or trunk charge. If a customer orders multiple lines or trunks on the same Access Order, the first line or trunk is assessed the "first" installation charge and each additional line or trunk is assessed the "each additional" installation charge per appropriate Interface Group category, per Access Order.

**NOTICE**  
**THE INFORMATION CONTAINED IN THIS DOCUMENT IS SUBJECT TO CHANGE.**

**Qwest Corporation**  
**Access Service**  
**Catalog No. 1**

**SECTION 6**  
Page 88  
Release 1  
Effective: 8-1-05

**NORTHERN IDAHO**  
Issued: 7-1-05

---

**6. SWITCHED ACCESS SERVICE**

**6.7 RATE REGULATIONS**

**6.7.1 DESCRIPTION AND APPLICATION OF RATES AND CHARGES**

C. Nonrecurring Charges (Cont'd)

2. Installation of Optional Features

Nonrecurring charges apply for the installation of some of the optional features available with Switched Access Service. The charges may apply whether the feature is installed coincident with the initial installation of service or at any time subsequent to the initial installation of service.

3. Service Rearrangements

Service rearrangements are changes to existing services installed which do not result in either a change in the minimum period requirements as set forth in 5.2.5, preceding, or a change in the physical location of the POT at a customer's premises or a customer's end user's premises. Changes which result in the establishment of new minimum period obligations are treated as disconnects and starts. Changes in the physical location of the POT are treated as moves and are described and charged for as set forth in 6.7.5, following.

The charge to the customer for the service rearrangement is dependent on whether the change is administrative only in nature or involves an actual technical and/or physical change to the service.

**NOTICE**  
**THE INFORMATION CONTAINED IN THIS DOCUMENT IS SUBJECT TO CHANGE.**

**Qwest Corporation**  
**Access Service**  
**Catalog No. 1**

**SECTION 6**  
Page 89  
Release 1  
Effective: 8-1-05

**NORTHERN IDAHO**  
Issued: 7-1-05

---

**6. SWITCHED ACCESS SERVICE**

**6.7 RATE REGULATIONS**

**6.7.1 DESCRIPTION AND APPLICATION OF RATES AND CHARGES**

C.3. (Cont'd)

Administrative changes will be made without charge(s) to the customer. Administrative changes are as follows:

- Change of customer name, (i.e., the customer of record does not change, but rather the customer of record changes its name, e.g., XYZ Company to XYZ Communications),
- Change of customer name as the result of a transfer of use of services as set forth in 2.1.2, preceding,
- Change of customer or customer's end user's premises address when the change of address is not a result of a physical relocation of equipment,
- Change in billing data (name, address or contact name or telephone number),
- Change of agency authorization,
- Change of customer circuit identification,
- Change of billing account number,
- Change of customer test line number,
- Change of customer or customer's end user's contact name or telephone number, and
- Change of jurisdiction.

**NOTICE**  
**THE INFORMATION CONTAINED IN THIS DOCUMENT IS SUBJECT TO CHANGE.**

**Qwest Corporation**  
**Access Service**  
**Catalog No. 1**

**SECTION 6**  
Page 90  
Release 1  
Effective: 8-1-05

**NORTHERN IDAHO**  
Issued: 7-1-05

---

**6. SWITCHED ACCESS SERVICE**

**6.7 RATE REGULATIONS**

**6.7.1 DESCRIPTION AND APPLICATION OF RATES AND CHARGES**

C.3. (Cont'd)

All other service rearrangements will be charged for as follows:

- If the change involves rearrangement of a customer's FGD trunks from direct routing to tandem routing, no charge shall apply for the customer requested rearrangement as long as the following conditions are met:
  - Tandem routing access was not available to the end office at the time the end office was converted to an equal access office,
  - The customer was providing service in the relevant area prior to the availability of tandem routing access, and
  - The customer requests the rearrangement of its trunks from direct routing access to tandem routing access within six months of the first availability of tandem routing access in that area.
- If, due to technical limitations of the Company, a customer could not combine its 800 DB Access Service and/or 900 Access Service traffic with its other Trunkside Switched Access Services, no charge shall apply to combine these trunk groups when it becomes technically possible.
- If, due to an office replacement, a customer requests conversion from one-way to two-way trunks, and the request is made six months in advance of the office replacement due date, the nonrecurring charges will not apply.

**NOTICE**  
**THE INFORMATION CONTAINED IN THIS DOCUMENT IS SUBJECT TO CHANGE.**

**Qwest Corporation**  
**Access Service**  
**Catalog No. 1**

**SECTION 6**  
Page 91  
Release 1  
Effective: 8-1-05

**NORTHERN IDAHO**  
Issued: 7-1-05

**6. SWITCHED ACCESS SERVICE**

**6.7 RATE REGULATIONS**

**6.7.1 DESCRIPTION AND APPLICATION OF RATES AND CHARGES**

C.3. (Cont'd)

For all other changes, including the addition of, or modifications to optional features without separate nonrecurring charges, a charge equal to one-half the Switched Transport per line or per trunk nonrecurring (i.e., installation) charge will apply. This one-half nonrecurring charge is assessed the "first" installation charge for the first line or trunk and each additional line or trunk is assessed the "each additional" installation charge per appropriate Interface Group category, per Access Order. If two or more optional features and changes are ordered on the same Access Order, the optional feature or change requiring the lowest level of work activity will apply. A maximum one-half nonrecurring charge will apply per Access Order for service rearrangements. If a feature is not required on each line or trunk, but rather for an entire hunt or trunk group, an end office or an access tandem switch, only one such charge will apply (i.e., it will not apply per line or trunk). This one-half nonrecurring charge is assessed the "first" installation charge for the first hunt group, trunk group, end office or access tandem switch and each additional hunt group, trunk group, end office or access tandem switch is assessed the "each additional" installation charge per appropriate Interface Group category, per Access Order. Nonrecurring charges for service rearrangements are specified in 6.8, following.

For additions and changes to optional features associated with WATS Access Service, the one-half nonrecurring charge is assessed the "first" installation charge for the first line or trunk and each additional line or trunk is assessed the "each additional" installation charge for Interface Group 6, per Access Order. This charge applies for all Network Channel Interface (NCI) codes associated with a WATS access line. If two or more optional features and changes are ordered on the same Access Order, the optional feature or change requiring the lowest level of work activity will apply. A maximum one-half nonrecurring charge will apply per Access Order for service rearrangements. If a feature is not required on each line but rather for an entire hunt group, only one such charge will apply (i.e., it will not apply per line). This one-half nonrecurring charge is assessed the "first" installation charge for the first hunt group and each additional hunt group is assessed the "each additional" installation charge per Interface Group 6, per Access Order. Nonrecurring charges for service rearrangements are specified in 6.8, following.

**NOTICE**  
**THE INFORMATION CONTAINED IN THIS DOCUMENT IS SUBJECT TO CHANGE.**

**Qwest Corporation**  
**Access Service**  
**Catalog No. 1**

**SECTION 6**  
Page 92  
Release 1  
Effective: 8-1-05

**NORTHERN IDAHO**  
Issued: 7-1-05

---

**6. SWITCHED ACCESS SERVICE**

**6.7 RATE REGULATIONS**

**6.7.1 DESCRIPTION AND APPLICATION OF RATES AND CHARGES**

C.3. (Cont'd)

If a change only involves the Switched Transport rating from TST to DTT or from DTT to TST between the SWC of the customer's premises and an access tandem and no actual technical and/or physical changes are required, a charge equal to one-half the Switched Transport trunk nonrecurring (i.e., installation) charge will apply. One-half of the "first" installation charge only will be assessed per appropriate Interface Group category, per Access Service Request, per access tandem. When actual technical and/or physical changes are required, then appropriate service rearrangement nonrecurring charges will be assessed.

A request to change FGD Service from a DTT or TST route to a DTT route equipped with TSI (where the Company Equal Access End Office subtends a customer-provided tandem) is a discontinuance of the existing service and an installation of a new service. All associated nonrecurring charges apply for the new service. Minimum period requirements for Switched Access Service apply as set forth in 5.2.5, preceding.

**NOTICE**  
**THE INFORMATION CONTAINED IN THIS DOCUMENT IS SUBJECT TO CHANGE.**

**Qwest Corporation**  
**Access Service**  
**Catalog No. 1**

**SECTION 6**  
Page 93  
Release 1  
Effective: 8-1-05

**NORTHERN IDAHO**  
Issued: 7-1-05

Effective: 8-1-05

## **6. SWITCHED ACCESS SERVICE**

### **6.7 RATE REGULATIONS**

#### **6.7.1 DESCRIPTION AND APPLICATION OF RATES AND CHARGES**

##### **C. Nonrecurring Charges (Cont'd)**

#### **4. Rearrangement of 800 DB Access Service from Tandem Routing to Direct Routing**

When the customer requests the rearrangement of 800 DB Access Service from tandem routing to direct routing, no charge shall apply for the customer requested rearrangement as long as the following conditions are met:

- The same customer premises, service type and Interface Group category are maintained with the exception of a change in service type as set forth in 6.7.4, following.
- The end office must subtend the tandem which service is being rearranged from.
- The customer must disconnect one trunk at the tandem for each rerouted end office trunk installed. Trunk rearrangements for more than one-for-one must be determined on an equivalent basis substantiated by industry accepted engineering standards and mutually agreed upon by the Company and the customer.
- The customer may specify a change in traffic type and direction (i.e., one-way to two-way) at the time the order is received.
- The customer may specify a change in optional features (except Switched Transport multiplexing) at the time the order is received. If the optional feature has a separate nonrecurring charge, that nonrecurring charge will apply. Requests for a rearrangement from MF to SS7 Out of Band Signaling must be received on a separate order.
- The Company must receive an ASR to connect 800 DB Access Service at the end office within six (6) months of the end office becoming SSP capable. The customer must place the order to disconnect from the tandem at the same time the order is placed to connect at the end office. The disconnect date may be negotiated with the Company not to exceed 90 days from the connect date.
- Customer specified rearrangement requests will be cooperatively negotiated with the customer and are subject to the availability of Company switching equipment and other existing facilities.

**NOTICE**  
**THE INFORMATION CONTAINED IN THIS DOCUMENT IS SUBJECT TO CHANGE.**

**Qwest Corporation**  
**Access Service**  
**Catalog No. 1**

**SECTION 6**  
Page 94  
Release 1  
Effective: 8-1-05

**NORTHERN IDAHO**  
Issued: 7-1-05

**6. SWITCHED ACCESS SERVICE**

**6.7 RATE REGULATIONS**

**6.7.1 DESCRIPTION AND APPLICATION OF RATES AND CHARGES**

C. Nonrecurring Charges (Cont'd)

5. Rearrangement from Multifrequency Signaling to SS7 Out of Band Signaling on FGD Service

Rearrangement of existing FGD Switched Access Service from Multifrequency (MF) signaling to SS7 Out of Band Signaling trunk groups will be performed at Company tandems and end offices designated as having SS7 capabilities. Service Rearrangement charges will apply when the following conditions are met:

- The same customer premises, quantity of trunks, service type, routing, traffic type, interface group category and optional features are maintained. Exceptions to this condition are set forth in I., following.
- The rearrangement of service from one-way to two-way transmission as well as from MF to SS7 Out of Band Signaling will be by trunk group(s) ordered and received at the same time.
- Multiple MF trunk groups may be combined into a single SS7 trunk group when all trunks within the group are traffic engineered as a unit and all the communications paths within the group are interchangeable.
- The disconnect date and the connect date is the same when rearranging trunk groups from MF to SS7 Out of Band Signaling.

Rearrangement charges from MF to SS7 Out of Band Signaling will be per trunk in each trunk group. The Service Order Rearrangement charge will be assessed per access order, per Interface Group. The trunk rearrangement charge will be assessed in association with the Interface Group Category 1, 2, 6 and 9. The trunk rearrangement charge will be applied per trunk in each SS7 Out of Band Signaling trunk group. The first trunk in the SS7 Out of Band Signaling trunk group will be charged the "first trunk" charge and each additional trunk in the same group will be charged the "each additional" trunk charge.

The Service Order Rearrangement charge and trunk rearrangement charge to change from MF to SS7 Out of Band Signaling are set forth in 6.8, following.

The description and application of rates and charges when rearranging FGD Service to SS7 Out of Band Signaling and Clear Channel Capability are set forth in I., following.

**NOTICE**  
**THE INFORMATION CONTAINED IN THIS DOCUMENT IS SUBJECT TO CHANGE.**

**Qwest Corporation**  
**Access Service**  
**Catalog No. 1**

**SECTION 6**  
Page 95  
Release 1  
Effective: 8-1-05

**NORTHERN IDAHO**  
Issued: 7-1-05

---

**6. SWITCHED ACCESS SERVICE**

**6.7 RATE REGULATIONS**

**6.7.1 DESCRIPTION AND APPLICATION OF RATES AND CHARGES (Cont'd)**

D. Application of Rates

1. Switched Transport and Local Switching rates are applied per access minute.
2. Where originating and/or terminating recording capability does not exist for FGA provided to an entry switch, the number of access minutes will be assumed as set forth in 6.7.6, following.
3. The Company will provide written notification to all access customers of record within a particular LATA that an end office in that LATA is scheduled to be converted to an equal access end office. This notification will be sent, via certified U.S. Mail, to each customer of record in the LATA where the conversion is scheduled to occur, at least six months in advance of the conversion date.
4. The customer will have the choice of converting existing services to equal access (i.e., originating and terminating Feature Group D) at no charge, pursuant to the conditions set forth in 6.7.4, following, or retaining the existing services.
5. When originating FGD is not available in an end office, and terminating FGD service to an access tandem in a LATA is available, such terminating FGD service may be used, at the option of the customer, to terminate FGD calls to that end office. FGD rates apply to all access minutes associated with such calls.

**NOTICE**  
**THE INFORMATION CONTAINED IN THIS DOCUMENT IS SUBJECT TO CHANGE.**

**Qwest Corporation**  
**Access Service**  
**Catalog No. 1**

**SECTION 6**  
Page 96  
Release 1  
Effective: 8-1-05

**NORTHERN IDAHO**  
Issued: 7-1-05

---

**6. SWITCHED ACCESS SERVICE**

**6.7 RATE REGULATIONS**

**6.7.1 DESCRIPTION AND APPLICATION OF RATES AND CHARGES (Cont'd)**

E. 900 Access Service Customer Identification Charge (CIC)

A 900 Access Service Customer Identification Charge is assessed for each 900 call delivered to the customer. This charge is in addition to the rates and charges for the rate categories described in 6.1.2, preceding, which are applicable to all Switched Access Services. The per-call rate is set forth in 6.8.2, following.

F. 900 Access Service Nonrecurring Charge

In addition to the rates and charges for the rate categories as described in 6.1.2, preceding, which are applicable to all Switched Access Services, the following charges apply to 900 Access Service:

1. There are two additional charges which apply to 1+900 Service to activate the 900 NXX code(s) for each end office. These charges are assessed on a first and subsequent NXX per access order, per screening location. The screening location, end office or tandem, is determined by where the six-digit translation of the 900 NXX portion of the dialed number is performed. These charges are set forth in 6.8, following.
2. There are two additional charges which apply to Expanded 0+900 Service to activate the Expanded 900 Option. These charges are assessed per access order, per screening location, end office or tandem with NXX activity or can be ordered without NXX activity. The Expanded 900 Option is not offered without 1+900 Access Service within a LATA and is available only with Feature Group D Service in suitably equipped Company end offices. These charges are set forth in 6.8, following.

**NOTICE**  
**THE INFORMATION CONTAINED IN THIS DOCUMENT IS SUBJECT TO CHANGE.**

**Qwest Corporation**  
**Access Service**  
**Catalog No. 1**

**SECTION 6**  
Page 97  
Release 1  
Effective: 8-1-05

**NORTHERN IDAHO**  
Issued: 7-1-05

---

**6. SWITCHED ACCESS SERVICE**

**6.7 RATE REGULATIONS**

**6.7.1 DESCRIPTION AND APPLICATION OF RATES AND CHARGES (Cont'd)**

G. 800 DB Access Service Rates and Charges

An 800 Carrier Identification Charge is assessed per call to the service provider the call is delivered to in accordance with SMS/800 information residing in the Company's SCP.

A POTS Translation Charge is assessed per call, in addition to the 800 Carrier Identification Charge, when the POTS number is delivered to the service provider instead of the 8XX number in accordance with SMS/800 information residing in the Company's SCP. The POTS Translation feature is described in 6.2.5, preceding.

A Call Handling and Destination Feature Charge is assessed on a per-query basis, in addition to the Carrier Identification Charge and the POTS Translation Charge, to the service provider the call is delivered to for each 8XX query to the Company's SCP that utilizes a Call Handling and Destination feature as described in 6.2.5, preceding. The query rate is assessed for all completed queries whether or not the actual 8XX call is delivered to the service provider.

These rates and charges are in addition to the rates and charges for the rate categories described in 6.1.2, preceding, which are applicable to all Switched Access Service. The 800 Data Base Access Service rates are set forth in 6.8.2, following.

**NOTICE**  
**THE INFORMATION CONTAINED IN THIS DOCUMENT IS SUBJECT TO CHANGE.**

**Qwest Corporation**  
**Access Service**  
**Catalog No. 1**

**SECTION 6**  
Page 98  
Release 1  
Effective: 8-1-05

**NORTHERN IDAHO**  
Issued: 7-1-05

Effective: 8-1-05

**6. SWITCHED ACCESS SERVICE**

**6.7 RATE REGULATIONS**

**6.7.1 DESCRIPTION AND APPLICATION OF RATES AND CHARGES (Cont'd)**

H. Multiple POTS Tandem Sectorization Nonrecurring Charge

The nonrecurring charges for MPTS are described as follows:

1. The MPTS ASR charge applies when a customer is ordering MPTS without associated trunk activity on the same order. This charge applies whether the order is to initially add sectors or make rearrangements to an existing sector(s). Trunk activity includes installing new trunks, adding additional trunks, rearranging existing trunks or removing trunks. This charge is in addition to the MPTS establishment charge (without associated trunk activity) and the MPTS rearrangement charge (without associated trunk activity).
2. The MPTS establishment charge (without associated trunk activity) applies when a customer orders MPTS service without associated trunk activity on the same order. The MPTS establishment charge (with associated trunk activity) applies when a customer orders MPTS service with associated trunk activity on the same order.
3. The MPTS rearrangement charge (without associated trunk activity) applies when a customer orders rearrangements to established MPTS service without associated trunk activity on the same order. The MPTS rearrangement charge (with associated trunk activity) applies when a customer orders rearrangements to established MPTS service with associated trunk activity on the same order. These charges are set forth in 6.8.1, following.

**NOTICE**  
**THE INFORMATION CONTAINED IN THIS DOCUMENT IS SUBJECT TO CHANGE.**

**Qwest Corporation**  
**Access Service**  
**Catalog No. 1**

**SECTION 6**  
Page 99  
Release 1  
Effective: 8-1-05

**NORTHERN IDAHO**  
Issued: 7-1-05

Effective: 8-1-05

**6. SWITCHED ACCESS SERVICE**

**6.7 RATE REGULATIONS**

**6.7.1 DESCRIPTION AND APPLICATION OF RATES AND CHARGES (Cont'd)**

I. Clear Channel Capability (CCC)

When Clear Channel Capability (CCC) is ordered and installed coincident with the initial installation of FGD Service, a CCC nonrecurring charge applies per trunk group in addition to the initial installation charge(s) for FGD Service. Rates and charges for CCC are as set forth in 6.8, following.

When CCC is ordered on existing trunkside service, the service may be rearranged when the following conditions are met:

1. The customer changes from FGD Service with multifrequency signaling to FGD Service with SS7 Out of Band Signaling and Clear Channel Capability with no other change in optional features.
2. The customer changes from FGD Service with SS7 Out of Band Signaling to FGD Service with SS7 Out of Band Signaling and Clear Channel Capability with no other change in optional features.
3. The same customer premises, quantity of trunks, service type, direct routing and Interface Group Category 6 or 9 are maintained.
4. The traffic type on FGD Service is changed to the Clear Channel Capability originating and/or terminating traffic type as set forth in 6.1.1, preceding.
5. All service orders are received at the same time and the disconnect date and the connect date are the same when rearranging trunk groups from MF to SS7 Out of Band Signaling with Clear Channel Capability.
6. Multiple MF trunk groups may be combined into a single SS7 trunk group with Clear Channel Capability when all trunks within the group are traffic engineered as a unit and all the communication paths within the group are interchangeable.

**NOTICE**  
**THE INFORMATION CONTAINED IN THIS DOCUMENT IS SUBJECT TO CHANGE.**

**Qwest Corporation**  
**Access Service**  
**Catalog No. 1**

**SECTION 6**  
Page 100  
Release 1  
Effective: 8-1-05

**NORTHERN IDAHO**  
Issued: 7-1-05

**6. SWITCHED ACCESS SERVICE**

**6.7 RATE REGULATIONS**

**6.7.1 DESCRIPTION AND APPLICATION OF RATES AND CHARGES**

I. Clear Channel Capability (CCC) (Cont'd)

Rearrangement charges from FGD Service with multifrequency signaling to FGD Service with SS7 Out of Band Signaling and Clear Channel Capability will be assessed the nonrecurring charges as set forth in 6.8, following.

Rearrangement charges from FGD Service with SS7 Out of Band Signaling to FGD Service with SS7 Out of Band Signaling and Clear Channel Capability will be assessed the "first trunk" charge in association with interface Group Category 6 or 9 service. Each additional trunk will be assessed the "each additional trunk" charge in association with Interface Group Category 6 or 9 service. The nonrecurring charge for Clear Channel Capability, as set forth in 6.8, following, is assessed per trunk group in addition to the nonrecurring charges per trunk as set forth in 6.8, following.

The removal of the CCC arrangement from existing trunkside service will be treated as a discontinuance of the existing service and installation of new service. All associated nonrecurring installation charges will apply for the new service. A new minimum period will be established for the new service.

J. Entrance Facility

The Entrance Facility monthly rate is assessed based on the type of facility provided, Voice Grade, DS1 or DS3. When Lineside Switched Access Service is provided, the Voice Grade Entrance Facility rate is assessed for each Lineside service provided, unless the customer requests a DS1 or DS3 Entrance Facility. The Entrance Facility rate is assessed even when the customer's premises and the SWC are located in the same building. The Entrance Facility rate is in addition to the rates assessed for DTT and/or TST. Rates are set forth in 6.8, following.

K. Direct-Trunked Transport

1. Except as set forth in 2. and 3., following, for each DTT facility provided, Voice Grade, DS1 or DS3, a fixed monthly rate, per mile band, and a monthly rate per mile is assessed. The DTT rates are in addition to the Entrance Facility rate. Mileage measurement is described in 6.7.10, following. Rates and charges are set forth in 6.8, following.

**NOTICE**  
**THE INFORMATION CONTAINED IN THIS DOCUMENT IS SUBJECT TO CHANGE.**

**Qwest Corporation**  
**Access Service**  
**Catalog No. 1**

**SECTION 6**  
Page 101  
Release 1  
Effective: 8-1-05

**NORTHERN IDAHO**  
Issued: 7-1-05

Effective: 8-1-05

**6. SWITCHED ACCESS SERVICE**

**6.7 RATE REGULATIONS**

**6.7.1 DESCRIPTION AND APPLICATION OF RATES AND CHARGES**

**K. Direct-Trunked Transport (Cont'd)**

2. When Lineside Switched Access Service is provided, the Voice Grade DTT rates are assessed for each Lineside service, unless the customer requests a DS1 or DS3 facility. DTT rates are assessed between the SWC of the customer's premises and the dial tone office. When traffic is terminated in an end office which is not the dial tone office, Tandem Transmission rates, as set forth in L., following, are assessed between the dial tone office and the end office where the traffic terminates. The Tandem Transmission rates are in addition to the DTT rates. Tandem Switching rates will not be assessed.
3. When the customer orders DTT to a remote switching system or module (RSS or RSM), DTT rates are assessed between the SWC and the host office and Tandem Transmission rates, as set forth in L., following, are assessed between the host and the RSS or RSM. Mileage measurement rules are set forth in 6.7.10, following. Tandem Switching rates will not be assessed.

**L. Tandem-Switched Transport**

The TST rate category is composed of Tandem Transmission rates and a rate for Tandem Switching. TST rates are in addition to the Entrance Facility rate. Mileage measurement is described in 6.7.10, following. Rates and charges are set forth in 6.8, following.

When the customer orders TST to a remote switching system or module (RSS or RSM), Tandem Transmission and Tandem Switching rates are assessed between the SWC and the host office or between the access tandem and the host office, whichever is applicable. In addition, Tandem Transmission rates are assessed between the host and the RSS or RSM. Mileage measurement rules are set forth in 6.7.10, following.

**1. Tandem Transmission**

The Tandem Transmission rates are assessed on a per-minute-of-use basis when TST is provided, and when DTT is provided as set forth in K., preceding. The Tandem Transmission rates are portrayed in mileage bands. There are two rates that apply for each band, a fixed rate per band and a rate per mile, per minute.

**NOTICE**  
**THE INFORMATION CONTAINED IN THIS DOCUMENT IS SUBJECT TO CHANGE.**

**Qwest Corporation**  
**Access Service**  
**Catalog No. 1**

**SECTION 6**  
Page 102  
Release 1  
Effective: 8-1-05

**NORTHERN IDAHO**  
Issued: 7-1-05

Effective: 8-1-05

**6. SWITCHED ACCESS SERVICE**

**6.7 RATE REGULATIONS**

**6.7.1 DESCRIPTION AND APPLICATION OF RATES AND CHARGES**

L. Tandem-Switched Transport (Cont'd)

2. Tandem Switching

The Tandem Switching rate is assessed on a per-minute-of-use basis to all Switched Access minutes when tandem switching functions are utilized.

M. Multiplexing

The multiplexing monthly rate is assessed on a per-arrangement basis.

**6.7.2 MINIMUM PERIODS**

Minimum periods for Switched Access Service are described in 5.2.5, preceding.

**6.7.3 MINIMUM MONTHLY CHARGE**

- A. Switched Access Service is subject to a minimum monthly charge. The minimum charge applies for the total capacity provided. The minimum monthly charge consists of the following elements:
- B. The minimum monthly charge for usage rated elements is the sum of the charges set forth in 6.8, following, for the measured or assumed usage for the month.
- C. For monthly rated elements, the minimum monthly charge is the monthly rate as set forth in 6.8, following.
- D. When FGA service is provided where actual measurement capabilities do not exist, the customer will always be billed for the assumed average number of access minutes for all applicable usage rated elements.

**NOTICE**  
**THE INFORMATION CONTAINED IN THIS DOCUMENT IS SUBJECT TO CHANGE.**

**Qwest Corporation**  
**Access Service**  
**Catalog No. 1**

**SECTION 6**  
Page 103  
Release 1  
Effective: 8-1-05

**NORTHERN IDAHO**  
Issued: 7-1-05

**6. SWITCHED ACCESS SERVICE**

**6.7 RATE REGULATIONS (Cont'd)**

**6.7.4 CHANGE OF SWITCHED ACCESS SERVICE TYPE**

Changes from one type of Switched Access Service to another will be treated as a discontinuance of service and the installation of service with the establishment of a new minimum period as set forth in 5.2.5, preceding. When the following conditions are met, the nonrecurring charges will not apply:

- A. Service type upgrade from Feature Group A or Feature Group B to Feature Group D Service
  1. The same customer premises, quantity of trunks, routing, traffic type, direction (i.e., one-way, two-way) and optional features are maintained,
  2. The same interface group category is maintained,
  3. The order for the disconnect of the or FGA Service or FGB Service and the start of FGD service are placed with the Company at the same time,
  4. The disconnect date for the FGA Service or FGB Service is no more than 90 days from the connect date of FGD Service.
- B. Service type upgrade from Feature Group C Service to Feature Group D Service
  1. When a FGC Service is upgraded to a FGD Service, the nonrecurring charge will not apply. Because FGC is no longer available in an end office once the end office is equipped with equal access capabilities, (i.e., FGD), such upgrades will be performed by the Company without the customer being required to place an order for the change unless the customer specifies a change in quantity of transmission paths.
  2. If a customer has the optional feature, Multiple POTs Tandem Sectorization (MPTS) and a non-equal access end office is upgraded to an equal access end office within the tandem serving area, the MPTS nonrecurring charges do not apply.
  3. When the effective dates for the disconnect and start of service are the same, minimum period obligations will not change, (i.e., the time elapsed in the existing minimum period obligations will be credited to the minimum period obligations for FGD). When the effective dates for the disconnect and start of service are different, new minimum period obligations will be established for the FGD service. For all other changes from one type of Feature Group to another, new minimum period obligations will also be established.

**NOTICE**  
**THE INFORMATION CONTAINED IN THIS DOCUMENT IS SUBJECT TO CHANGE.**

**Qwest Corporation**  
**Access Service**  
**Catalog No. 1**

**SECTION 6**  
Page 104  
Release 1  
Effective: 8-1-05

**NORTHERN IDAHO**  
Issued: 07-1-05

**6. SWITCHED ACCESS SERVICE**

**6.7 RATE REGULATIONS (Cont'd)**

**6.7.5 MOVES**

A move involves a change in the physical location or reconfiguration of the following:

- The POT of the Entrance Facility (EF) at the customer's premises is moving
- The customer's premises and associated EF is moving
- The DTT or TST facilities and associated Lineside and/or Trunkside Switched Access Services are reconfigured as set forth in A. and B., following.

The charges for a move or reconfiguration are dependent on whether the move or reconfiguration is within the same serving wire center (as set forth in A., following) or to a different serving wire center (as set forth in B., following). New minimum period requirements will be established for moved or reconfigured services. Any changes to the existing Switched Access facilities, lines, trunks and optional features as they exist at the current location, excluding a change in Circuit Facility Assignment (CFA), made in conjunction with a move or reconfiguration, will be treated as a discontinuance and a start of new service and all associated nonrecurring installation charges will apply. The addition of lines and trunks made in conjunction with a move or reconfiguration will be treated as a start of new service and all associated nonrecurring installation charges and new minimum period requirements will apply. The customer will also remain responsible for satisfying all outstanding minimum period charges for any disconnected service as the result of a move or reconfiguration.

**NOTICE**  
**THE INFORMATION CONTAINED IN THIS DOCUMENT IS SUBJECT TO CHANGE.**

**Qwest Corporation**  
**Access Service**  
**Catalog No. 1**

**SECTION 6**  
Page 105  
Release 1  
Effective: 8-1-05

**NORTHERN IDAHO**  
Issued: 07-1-05

**6. SWITCHED ACCESS SERVICE**

**6.7 RATE REGULATIONS**  
**6.7.5 MOVES (Cont'd)**

- A. Application of Move Charges Within the Same Serving Wire Center (SWC)
1. EF Move to a New Location Within the Same Building, same SWC, for the Same Customer

The charge for moving an EF to a new location within the same building, same SWC, for the same customer, is one-half of the Move Within the Same Serving Wire Center charge as set forth in 6.8.1, following. The first line or trunk is assessed one-half of the "first" move charge and each additional line or trunk is assessed one-half of the "each additional" move charge per Interface Group 1, 2, 6 or 9, per Access Order. In addition, one-half of the EF Nonrecurring Installation charge based on the capacity affected, per point of termination, per Access Order is assessed.

2. Reconfiguration of DTT or TST Facilities and Associated Lineside or Trunkside Switched Access Services from an EF of One Customer to an EF of Another Customer or to an EICT[1], all Within the Same Building, Same SWC

The charge for reconfiguring DTT or TST facilities and associated Lineside or Trunkside Switched Access Services from an EF of one customer to (a.) an EF of another customer where its customer premises is located within the same building, same SWC, or (b.) to an EICT located within the same building, same SWC, is one-half of the Move Within the Same Serving Wire Center charge as set forth in 6.8.1, following. The first line or trunk is assessed one-half of the "first" move charge and each additional line or trunk is assessed one-half of the "each additional" move charge per Interface Group 1, 2, 6 or 9, per Access Order. The customer providing the EF or EICT is responsible for providing the CFA and is assessed an EF or EICT Nonrecurring Installation charge when a new EF or EICT is ordered.

[1] Expanded Interconnection Channel Termination (EICT) as set forth in Section 21, following

**NOTICE**  
**THE INFORMATION CONTAINED IN THIS DOCUMENT IS SUBJECT TO CHANGE.**

**Qwest Corporation**  
**Access Service**  
**Catalog No. 1**

**SECTION 6**  
Page 106  
Release 1  
Effective: 8-1-05

**NORTHERN IDAHO**  
Issued: 7-1-05

**6. SWITCHED ACCESS SERVICE**

**6.7 RATE REGULATIONS**

**6.7.5 MOVES**

- A. Application of Move Charges Within the Same Serving Wire Center (SWC) (Cont'd)

3. Reconfiguration of DTT or TST Facilities and Associated Lineside or Trunkside Switched Access Services from One EICT to Another EICT, all Within the Same Building, Same SWC

The charge for reconfiguring DTT or TST facilities and associated Lineside or Trunkside Switched Access Services from one EICT to another EICT within the same building, same SWC, is one-half of the Move Within the Same Serving Wire Center charge as set forth in 6.8.1, following. The first line or trunk is assessed one-half of the "first" move charge and each additional line or trunk is assessed one-half of the "each additional" move charge per Interface Group 1, 2, 6 or 9, per Access Order. The customer providing the EICT is responsible for providing the CFA and is assessed an EICT Nonrecurring Installation charge when a new EICT is ordered.

4. Reconfiguration of DTT or TST Facilities and Associated Lineside or Trunkside Switched Access Services from an EICT to an EF, all Located Within the Same Building, same SWC

The charge for reconfiguring DTT or TST facilities and associated Lineside or Trunkside Switched Access Services from an EICT to an EF where its customer premises is located within the same building, same SWC, is one-half of the Move Within the Same Serving Wire Center charge as set forth in 6.8.1, following. The first line or trunk is assessed one-half of the "first" move charge and each additional line or trunk is assessed one-half of the "each additional" move charge per Interface Group 1, 2, 6 or 9, per Access Order. The customer providing the EF is responsible for providing the CFA and is assessed an EF Nonrecurring Installation charge when a new EF is ordered.

**NOTICE**  
**THE INFORMATION CONTAINED IN THIS DOCUMENT IS SUBJECT TO CHANGE.**

**Qwest Corporation**  
**Access Service**  
**Catalog No. 1**

**SECTION 6**  
Page 107  
Release 1  
Effective: 8-1-05

**NORTHERN IDAHO**  
Issued: 07-1-05

**6. SWITCHED ACCESS SERVICE**

**6.7 RATE REGULATIONS**

**6.7.5 MOVES**

A. Moves Within The Same Serving Wire Center (Cont'd)

5. EF Move to a Different Building, Same SWC for the Same Customer

The charge for moving an EF to a different building, same SWC, for the same customer is the Move Within the Same Serving Wire Center charge as set forth in 6.8.1, following. The first line or trunk is assessed the "first" move charge and each additional line or trunk is assessed the "each additional" move charge per Interface Group 1, 2, 6 or 9, per Access Order. In addition, a full EF Nonrecurring Installation charge based on the capacity affected, per point of termination, per Access Order is assessed.

6. Reconfiguration of DTT or TST Facilities and Associated Lineside or Trunkside Switched Access Services from an EF of One Customer to an EF of Another Customer or to an EICT Located in a Different Building, Same SWC

The charge for reconfiguring DTT or TST facilities and associated Lineside or Trunkside Switched Access Services from an EF of one customer to (a.) an EF of another customer where its customer premises is located in a different building, same SWC, or (b.) to an EICT located in a different building, same SWC is the Move Within the Same Serving Wire Center charge as set forth in 6.8.1, following. The first line or trunk is assessed the "first" move charge and each additional line or trunk is assessed the "each additional" move charge per Interface Group 1, 2, 6 or 9, per Access Order. The customer providing the EF or EICT is responsible for providing the CFA and is assessed an EF or EICT Nonrecurring Installation charge when a new EF or EICT is ordered.

**NOTICE**  
**THE INFORMATION CONTAINED IN THIS DOCUMENT IS SUBJECT TO CHANGE.**

**Qwest Corporation**  
**Access Service**  
**Catalog No. 1**

**SECTION 6**  
Page 108  
Release 1  
Effective: 8-1-05

**NORTHERN IDAHO**  
Issued: 07-1-05

**6. SWITCHED ACCESS SERVICE**

**6.7 RATE REGULATIONS**

**6.7.5 MOVES**

- A. Application of Move Charges Within the Same Serving Wire Center (SWC) (Cont'd)

7. Reconfiguration of DTT or TST Facilities and Associated Lineside or Trunkside Switched Access Services from an EICT to an EF Located in a Different Building, Same SWC

The charge for reconfiguring DTT or TST facilities and associated Lineside or Trunkside Switched Access Services from an EICT to an EF where its customer premises is located in a different building, same SWC, is the Move Within the Same Serving Wire Center charge as set forth in 6.8.1, following. The first line or trunk is assessed the "first" move charge and each additional line or trunk is assessed the "each additional" move charge per Interface Group 1, 2, 6 or 9, per Access Order. The customer providing the EF is responsible for providing the CFA and is assessed an EF Nonrecurring Installation charge when a new EF is ordered.

- B. Application of Move Charges to a Different Serving Wire Center (SWC)

1. EF Move to a Different SWC for the Same Customer

The charge for moving an EF to a different SWC for the same customer is assessed the Move to a Different Serving Wire Center charge as set forth in 6.8.1, following. The first line or trunk is assessed the "first" move charge and each additional line or trunk is assessed the "each additional" move charge per Interface Group 1, 2, 6 or 9, per Access Order. In addition, a full EF Nonrecurring Installation charge based on the capacity affected, per point of termination, per Access Order is assessed.

2. Reconfiguration of DTT or TST Facilities and Associated Lineside or Trunkside Switched Access Services from an EF of One Customer to an EF of Another Customer or to an EICT in a Different SWC

**NOTICE**  
**THE INFORMATION CONTAINED IN THIS DOCUMENT IS SUBJECT TO CHANGE.**

**Qwest Corporation**  
**Access Service**  
**Catalog No. 1**

**SECTION 6**  
Page 109  
Release 1  
Effective: 8-1-05

**NORTHERN IDAHO**  
Issued: 7-1-05

---

**6. SWITCHED ACCESS SERVICE**

**6.7 RATE REGULATIONS**

**6.7.5 MOVES**

B.2. (Cont'd)

The charge for reconfiguring DTT or TST facilities and associated Lineside or Trunkside Switched Access Services from an EF of one customer to (a) an EF of another customer where its customer premises is served by a different SWC or (b) to an EICT located in a different SWC is the Move to A Different Serving Wire Center charge as set forth in 6.8.1, following. The first line or trunk is assessed of the "first" move charge and each additional line or trunk is assessed of the "each additional" move charge per Interface Group 1, 2, 6 or 9, per Access Order. The customer providing the EF or EICT is responsible for providing the CFA and is assessed an EF or EICT Nonrecurring Installation charge when a new EF or EICT is ordered.

3. Reconfiguration of DTT or TST Facilities and Associated Lineside or Trunkside Switched Access Services from One EICT to Another EICT Located in a Different SWC

The charge for reconfiguring DTT or TST facilities and associated Lineside or Trunkside Switched Access Services from one EICT to another EICT located in a different SWC is the Move to a Different Serving Wire Center charge as set forth in 6.8.1, following. The first line or trunk is assessed the "first" move charge and each additional line or trunk is assessed the "each additional" move charge per Interface Group 1, 2, 6 or 9, per Access Order. The customer providing the EICT is responsible for providing the CFA and is assessed an EICT Nonrecurring Installation charge when a new EICT is ordered.

4. Reconfiguration of DTT or TST Facilities and Associated Lineside or Trunkside Switched Access Services from an EICT to an EF Located in a Different SWC

The charge for reconfiguring DTT or TST facilities and associated Lineside or Trunkside Switched Access Services from an EICT to an EF where its customer premises is served by a different SWC is the Move to a Different Serving Wire Center charge as set forth in 6.8.1, following. The first line or trunk is assessed the "first" move charge and each additional line or trunk is assessed the "each additional" move charge per Interface Group 1, 2, 6 or 9, per Access Order. The customer providing the EF is responsible for providing the CFA and is assessed an EF Nonrecurring Installation charge when a new EF is ordered.

**NOTICE**  
**THE INFORMATION CONTAINED IN THIS DOCUMENT IS SUBJECT TO CHANGE.**

**Qwest Corporation**  
**Access Service**  
**Catalog No. 1**

**SECTION 6**  
Page 110  
Release 1  
Effective: 8-1-05

**NORTHERN IDAHO**  
Issued: 7-1-05

Effective: 8-1-05

---

**6. SWITCHED ACCESS SERVICE**

**6.7 RATE REGULATIONS (Cont'd)**

**6.7.6 MEASURING ACCESS MINUTES**

Customer traffic to end office switches will be measured (i.e., recorded or assumed) by the Company at end office switches or access tandem switches. Originating and terminating calls will be measured (i.e., recorded or assumed) by the Company to determine the basis for computing chargeable access minutes. For terminating calls over FGA, FGB, FGC to 800/800-type and FGD, and for originating calls over FGA used for resale, FGB, FGC (where measurement capability is available), and FGD, the measured minutes are the chargeable access minutes. For originating calls over FGA not used for resale, and FGC (where measurement capability is not available), chargeable originating access minutes are derived from recorded minutes in the following manner.

Step 1:

Obtain recorded originating minutes and messages (measured as set forth in A. and C., following, for FGA not used for resale and FGC where measurement capability is not available, respectively) from the appropriate recording data.

Step 2:

Obtain the total messages and attempts by multiplying the originating measured messages by the "attempts per message ratio". "Attempts per message ratios" (A/M) are obtained separately for the major call categories such as DDD, operator, 8XX and 900, from a sample study which analyzes the ultimate completion status of the total attempts which receive acknowledgment from the customer. That is, Measured Messages divided by Completion Ratio equals Total Attempts.

**NOTICE**  
**THE INFORMATION CONTAINED IN THIS DOCUMENT IS SUBJECT TO CHANGE.**

**Qwest Corporation**  
**Access Service**  
**Catalog No. 1**

**SECTION 6**  
Page 111  
Release 1  
Effective: 8-1-05

**NORTHERN IDAHO**  
Issued: 7-1-05

**6. SWITCHED ACCESS SERVICE**

**6.7 RATE REGULATIONS**

**6.7.6 MEASURING ACCESS MINUTES (Cont'd)**

Step 3:

Obtain the total non-conversation time additive (NCTA) by multiplying the total attempts (obtained in Step 2) by the NCTA per attempt ratio. The NCTA per attempt ratio is obtained from the sample study identified in Step 2 by measuring the non-conversation time associated with both completed and incompleting attempts. The total NCTA is the time on a completed attempt from customer acknowledgment of receipt of call to called party answer (set up and ringing) plus the time on an incompleting attempt from customer acknowledgment of call until the access tandem or end office receives a disconnect signal (ring - no answer, busy or network blockage). That is, Total Attempts times Non-Conversation Time per Attempt Ratio equals Total NCTA.

Step 4:

Obtain total chargeable originating access minutes by adding the total NCTA (obtained in Step 3) to the recorded originating measured minutes (obtained in Step 1). That is, Measured Minutes plus NCTA equals Chargeable Originating Access Minutes.

Following is an example which illustrates how the chargeable originating access minutes are derived from the measured originating minutes using this formula.

Where:	Measured Minutes (M. Min.) .....	=	7,000
	Measured Messages (M. Mes.).....	=	1,000
	Attempts Per Message Ratio (A/M) .....	=	1.3330
	NCTA Per Attempt.....	=	.4
1.	Total Attempts = 1,000 (M. Mes.) x 1.333.....	=	1,333
2.	Total NCTA = .4 (NCTA per Attempt) x 1,333.....	=	533.2
3.	Total Chargeable Originating Access Minutes = 7,000 (M. Min.) + 533.2 (NCTA) .....	=	7,533.2

When assumed minutes are used, the assumed minutes are the chargeable access minutes.

**NOTICE**  
**THE INFORMATION CONTAINED IN THIS DOCUMENT IS SUBJECT TO CHANGE.**

**Qwest Corporation**  
**Access Service**  
**Catalog No. 1**

**SECTION 6**  
Page 112  
Release 1  
Effective: 8-1-05

**NORTHERN IDAHO**  
Issued: 7-1-05

**6. SWITCHED ACCESS SERVICE**

**6.7 RATE REGULATIONS**  
**6.7.6 MEASURING ACCESS MINUTES (Cont'd)**

FGA access minutes or fractions thereof, the exact value of the fraction being a function of the switch technology where the measurement is made, are accumulated over the billing period for each line or hunt group, and are then rounded up to the nearest access minute for each line or hunt group. FGB, FGC and FGD access minutes or fractions thereof, the exact value of the fraction being a function of the switch technology where the measurement is made, are accumulated over the billing period for each end office, and are then rounded up to the nearest access minute for each end office.

Assumed minutes are used for FGA services which originate or terminate in end offices not equipped with measurement capabilities.

The following assumed minutes are used in the computation of Switched Access Service charges.

The assumed average intrastate access minutes are as set forth following.

When a FGA service arranged for two way calling provided when neither the originating nor terminating access minutes are recorded, the assumed average intrastate access minutes are 7374 access minutes. 3471 access minutes are assumed to be originating and 3903 access minutes are assumed to be terminating. Where recording capability exists for either originating or terminating usage, but not both, on a line arranged for two way calling, the number of access minutes per line will be an assumed 7374 or the recorded usage, whichever is greater. If the usage in the measured direction exceeds 7374 access minutes, it will be assumed that there is zero usage in the unmeasured direction. If the measured usage is less than 7374 access minutes, the usage in the unmeasured direction will be assumed to be 7374 access minutes minus the measured usage (e.g., 7374 - 4000 measured = 3374 assumed in unmeasured direction).

**NOTICE**  
**THE INFORMATION CONTAINED IN THIS DOCUMENT IS SUBJECT TO CHANGE.**

**Qwest Corporation**  
**Access Service**  
**Catalog No. 1**

**SECTION 6**  
Page 113  
Release 1  
Effective: 8-1-05

**NORTHERN IDAHO**  
Issued: 7-1-05

Effective: 8-1-05

**6. SWITCHED ACCESS SERVICE**

**6.7 RATE REGULATIONS**

**6.7.6 MEASURING ACCESS MINUTES (Cont'd)**

When a service arranged for originating calling only is provided where originating access minutes are not recorded, the assumed average originating access minutes are 3471 access minutes and no terminating access minutes will apply.

When a service arranged for terminating calling only is provided where terminating access minutes are not recorded, the assumed average terminating access minutes are 3903 access minutes and no originating access minutes will apply.

**A. Feature Group A Usage Measurement**

1. For originating calls over FGA, usage measurement begins when the originating FGA entry switch receives an off-hook supervisory signal forwarded from the customer's POT. (Where FGA is used for resale, this off-hook signal is generally provided by the customer's equipment. Where FGA is not used for resale, the off-hook signal is generally forwarded by the customer's equipment when the called party answers.)
2. The measurement of originating call usage over FGA ends when the originating FGA entry switch receives an on-hook supervisory signal from either the originating end user's end office, indicating the originating end user has disconnected, or the customer's POT, whichever is recognized first by the entry switch.
3. For terminating calls over FGA, usage measurement begins when the terminating entry switch receives an off-hook supervisory signal from the terminating end user's end office, indicating the terminating end user has answered. The measurement of terminating call usage over FGA ends when the terminating FGA entry switch receives an on-hook supervisory signal from either the terminating end user's end office, indicating the terminating end user has disconnected, or the customer's POT, whichever is recognized first by the entry switch.

**NOTICE**  
**THE INFORMATION CONTAINED IN THIS DOCUMENT IS SUBJECT TO CHANGE.**

**Qwest Corporation**  
**Access Service**  
**Catalog No. 1**

**SECTION 6**  
Page 114  
Release 1  
Effective: 8-1-05

.1  
**NORTHERN IDAHO**  
Issued: 7-1-05

---

**6. SWITCHED ACCESS SERVICE**

**6.7 RATE REGULATIONS**

**6.7.6 MEASURING ACCESS MINUTES (Cont'd)**

B. Feature Group B Usage Measurement

1. For originating calls over FGB, usage measurement begins when the originating FGB entry switch receives answer supervision forwarded from the customer's POT, indicating the customer's equipment has answered.
2. The measurement of originating call usage over FGB ends when the originating FGB entry switch receives disconnect supervision from either the originating end user's end office, indicating the originating end user has disconnected, or the customer's POT, whichever is recognized first by the entry switch.
3. For terminating calls over FGB, usage measurement begins when the terminating FGB entry switch receives answer supervision from the terminating end user's end office, indicating the terminating end user has answered.
4. The measurement of terminating call usage over FGB ends when the terminating FGB entry switch receives disconnect supervision from either the terminating end user's end office, indicating the terminating end user has disconnected, or the customer's POT, whichever is recognized first by the entry switch.

**NOTICE**  
**THE INFORMATION CONTAINED IN THIS DOCUMENT IS SUBJECT TO CHANGE.**

**Qwest Corporation**  
**Access Service**  
**Catalog No. 1**

**SECTION 6**  
Page 115  
Release 1  
Effective: 8-1-05

**NORTHERN IDAHO**  
Issued: 7-1-05

---

**6. SWITCHED ACCESS SERVICE**

**6.7 RATE REGULATIONS**

**6.7.6 MEASURING ACCESS MINUTES (Cont'd)**

C. Feature Group C Usage Measurement

1. For originating calls over FGC, if measurement capabilities are not available, usage measurement begins when the originating FGC entry switch receives answer supervision from the customer's POT, indicating the called party has answered. If measurement capabilities are available, usage measurement begins when the originating FGC entry switch receives the first wink supervisory signal forwarded from the customer's POT.
2. The measurement of originating call usage over FGC ends when the originating FGC entry switch receives disconnect supervision from either the originating end user's end office, indicating the originating end user has disconnected, or the customer's POT, whichever is recognized first by the entry switch.
3. For terminating calls over FGC to services other than 800/800-type or 900, terminating FGC usage may not be directly measured at the terminating entry switch, but may be imputed from originating usage, excluding usage from calls to 800/800-type or 900 Services. Actual measured usage will be used where available rather than an imputed value.
4. For terminating calls over FGC to 800/800-type service, usage measurement begins when the terminating FGC entry switch receives answer supervision from the terminating end user's end office, indicating the terminating end user has answered.
5. The measurement of terminating call usage over FGC to 800/800-type service ends when the terminating FGC entry switch receives an on-hook supervisory signal from the terminating end user's end office, indicating the terminating end user has disconnected, or from the customer's POT, whichever is recognized first by the entry switch.

**NOTICE**  
**THE INFORMATION CONTAINED IN THIS DOCUMENT IS SUBJECT TO CHANGE.**

**Qwest Corporation**  
**Access Service**  
**Catalog No. 1**

**SECTION 6**  
Page 116  
Release 1  
Effective: 8-1-05

**NORTHERN IDAHO**  
Issued: 7-1-05

---

**6. SWITCHED ACCESS SERVICE**

**6.7 RATE REGULATIONS**

**6.7.6 MEASURING ACCESS MINUTES (Cont'd)**

D. Feature Group D Usage Measurement

1. Originating Usage Measurement

a. Multifrequency Signaling

- For originating calls over FGD, usage measurement begins when the originating FGD entry switch receives the first wink supervisory signal forwarded from the customer's POT.
- The measurement of originating call usage over FGD ends when the originating FGD entry switch receives disconnect supervision from either the originating end user's end office, indicating the originating end user has disconnected, or the customer's POT, whichever is recognized first by the entry switch.

b. SS7 Out of Band Signaling

- For originating calls over FGD, usage measurement on direct trunks begins when the FGD entry switch sends an Initial Address Message (IAM). The usage measurement for tandem trunks via an access tandem or customer-provided tandem switch begins when the FGD entry switch receives an Exit Message (EXM).
- The measurement of originating call usage over FGD with SS7 Out of Band Signaling ends when a Release Message is sent or received by the originating end user's end office, whichever occurs first.

2. Terminating Usage Measurement

- For terminating calls over FGD, the measurement of access minutes begins when the terminating FGD entry switch receives answer supervision from the terminating end user's end office, indicating the terminating end user has answered.
- The measurement of terminating call usage over FGD ends when the terminating FGD entry switch receives disconnect supervision from either the terminating end user's end office, indicating the terminating end user has disconnected, or the customer's POT, whichever is recognized first by the entry switch.

**NOTICE**  
**THE INFORMATION CONTAINED IN THIS DOCUMENT IS SUBJECT TO CHANGE.**

**Qwest Corporation**  
**Access Service**  
**Catalog No. 1**

**SECTION 6**  
Page 117  
Release 1  
Effective: 8-1-05

**NORTHERN IDAHO**  
Issued: 7-1-05

---

**6. SWITCHED ACCESS SERVICE**

**6.7 RATE REGULATIONS (Cont'd)**

**6.7.7 APPLICATION OF RATES FOR EXTENSION SERVICE**

Feature Group A Switched Access Service is available with extensions, i.e., additional terminations of the service at different building(s) in the same or a different exchange or in the same or a different LATA. The extensions are available as set forth in the Private Line Transport Catalog.

**6.7.8 MESSAGE UNIT CREDIT**

Calls from end users to the seven digit local telephone numbers associated with Feature Group A Switched Access Service are subject to charges in the Exchange and Network Services Catalog including message unit and toll charges as applicable. The monthly bills rendered to customers for their Feature Group A Switched Access Service for which Carrier Common Line rates apply will include a credit to reflect any message unit charges collected from their end users as described preceding. The credit will apply for recorded originating usage or for assumed originating usage, as appropriate, for the service provided. When the credit is applied on assumed usage, such credit will not exceed the assumed levels of usage as set forth in 6.7.6, preceding. No Message Unit Credit will apply for any terminating access minutes. The Message Unit Credit for originating access minutes is as set forth in 6.8, following.

**6.7.9 LOCAL INFORMATION DELIVERY SERVICES**

Calls over Switched Access in the terminating direction to certain community information services will be rated under the applicable rates for Switched Access Service as set forth in 6.8, following. In addition, non-access charges will also apply in accordance with the Information Provider's applicable service rates when the Company performs the billing function for that Information Provider.

**NOTICE**  
**THE INFORMATION CONTAINED IN THIS DOCUMENT IS SUBJECT TO CHANGE.**

**Qwest Corporation**  
**Access Service**  
**Catalog No. 1**

**SECTION 6**  
Page 118  
Release 1  
Effective: 8-1-05

**NORTHERN IDAHO**  
Issued: 7-1-05

**6. SWITCHED ACCESS SERVICE**

**6.7 RATE REGULATIONS (Cont'd)**

**6.7.10 MILEAGE MEASUREMENT**

The mileage to be used to determine the rate for DTT and TST is calculated on the airline distance between the end office switch where the call carried by Switched Transport originates or terminates and the customer's serving wire center (SWC), except as set forth in A. through H., following. The V & H coordinates method is used to determine mileage. This method is set forth in the National Exchange Carrier Association Tariff F.C.C. No. 4 for Wire Center Information (V & H coordinates).

Mileage is shown in 6.8, following, in terms of mileage bands. To determine the rate to be billed, first compute the mileage using the V & H coordinates method, then find the band into which the computed mileage falls and apply the rate shown for that band. If the calculation results in a fraction of a mile, always round up to the next whole mile before determining the mileage band and applying the rates.

Exceptions to the mileage measurement rules are as follows:

- A. Mileage for Lineside Switched Access Service provided as DTT in the originating direction is calculated on an airline basis, using the V & H coordinates method, between the end office switch where the Feature Group A switching dial tone is provided and the customer's SWC for the Switched Access Service provided.

Mileage for Lineside Switched Access Service provided by DTT in the terminating direction is calculated on an airline basis, using V & H coordinates method, between the end office switch where the FGA switching dial-tone is provided and the customer's SWC when traffic is terminated in the dial-tone office or an end office without measurement capability. When traffic is terminated in an end office with measurement capability and is not the dial-tone office, Tandem Transmission rates are applicable as set forth in 6.7.1, preceding, and mileage will be calculated between the dial-tone office and the end office where the traffic terminates for the application of Tandem Transmission rates. The Tandem Transmission rates are in addition to the DTT rates.

This exception does not apply to Access Service that originates from or terminates in an Extended Area Service calling area.

**NOTICE**  
**THE INFORMATION CONTAINED IN THIS DOCUMENT IS SUBJECT TO CHANGE.**

**Qwest Corporation**  
**Access Service**  
**Catalog No. 1**

**SECTION 6**  
Page 119  
Release 1  
Effective: 8-1-05

**NORTHERN IDAHO**  
Issued: 7-1-05

---

**6. SWITCHED ACCESS SERVICE**

**6.7 RATE REGULATIONS**

**6.7.10 MILEAGE MEASUREMENT (Cont'd)**

- B. With the exception of FGD with MPTS as described in 6.1.2.A.4.d., preceding, when the Alternate Traffic Routing optional feature is provided with originating Trunkside Access (including FGC with MPTS) to provide service from an end office to different customer premises locations via TST from the SWC to subtending end offices, Switched Transport access minutes will be apportioned between the transmission routes used to provide this feature to determine the Switched Transport mileage. When the feature is provided at an end office switch, or to the subtending end offices when the feature is provided at an access tandem switch, the total Switched Transport access minutes for that end office will be apportioned among the trunk groups accessing the end office on the basis of the individual capacity, (i.e., busy hour minutes or number of trunks), ordered for each of those trunk groups. A 30 BHM capacity per trunk will be applied when ordered in trunks. This apportionment will serve as the basis for the Switched Transport mileage calculation.
- C. When the customer orders Access Service via DTT to a remote switching system or module (RSS or RSM), both DTT and Tandem Transmission rates apply as set forth in 6.7.1, preceding. Mileage for DTT is calculated on an airline basis between the SWC of the customer's premises or Company Hub, whichever is applicable, and the host office for the RSS or RSM. Mileage for Tandem Transmission is calculated between the host office and the RSS or RSM. When mileage cannot be calculated to the RSS or RSM, DTT mileage will be calculated to the host office.

When the customer orders TST to a RSS or RSM, mileage for Tandem Transmission is calculated between the SWC of the customer's premises or access tandem, whichever is applicable, and the host office and then a second mileage measurement is calculated between the host office and the RSS or RSM. If mileage cannot be calculated to the RSS or RSM, mileage will be calculated to the host office.

**NOTICE**  
**THE INFORMATION CONTAINED IN THIS DOCUMENT IS SUBJECT TO CHANGE.**

**Qwest Corporation**  
**Access Service**  
**Catalog No. 1**

**SECTION 6**  
Page 120  
Release 1  
Effective: 8-1-05

**NORTHERN IDAHO**  
Issued: 7-1-05

**6. SWITCHED ACCESS SERVICE**

**6.7 RATE REGULATIONS**

**6.7.10 MILEAGE MEASUREMENT (Cont'd)**

- D. When Trunkside Switched Access Service is terminated from multiple customer's premises through an access tandem, the customer shall provide to the Company the percentage of traffic from each POT to each end office. The mileage to be used to determine the TST rate is calculated as set forth preceding. However, the appropriate access minutes for each POT that terminates traffic through the access tandem will be determined by applying the percentages provided by the customer to the total access minutes recorded at each end office. The Company may request verification audits, not to exceed one per year, per location, per customer, at specific intervals of substantial duration (i.e., annual intervals). The audits will be conducted by independent auditors if the Company and the customer or the customer alone is willing to pay the expense.

Effective on the first of January, April, July and October of each year, the customer may report changes to the percentages of terminating Feature Group B, C and D services. The customer shall forward to the Company, to be received no later than 15 days after the first of each such month, a revised report showing the designation of the terminating minutes for the past three months ending the last day of December, March, June and September, respectively, for each service. The revised report will serve as a basis for the next three months' billing and will be effective on the next bill date for that service. No prorating or back billing will be done based on the report.

If the customer does not furnish a report to the Company stating the percentages on Feature Group B, C and D Services terminated from multiple customer premises through an access tandem, the total Switched Transport access minutes for that end office will be apportioned among the trunk groups accessing the end office on the basis of the individual capacity, (i.e., busy hour minutes or number of trunks), ordered for each of those trunk groups. A 30 BHM capacity per trunk will be applied when ordered in trunks.

- E. When the Switched Transport for Switched Access Service is provided by the Company and the end user connection is provided by a CMRS provider, mileage for Access will be calculated on an airline basis, using the V & H coordinates method, based on the routing (tandem or direct). The SWC of the MTSO functions as the end office for mileage calculations.

**NOTICE**  
**THE INFORMATION CONTAINED IN THIS DOCUMENT IS SUBJECT TO CHANGE.**

**Qwest Corporation**  
**Access Service**  
**Catalog No. 1**

**SECTION 6**  
Page 121  
Release 1  
Effective: 8-1-05

**NORTHERN IDAHO**  
Issued: 7-1-05

Effective: 8-1-05

**6. SWITCHED ACCESS SERVICE**

**6.7 RATE REGULATIONS**

**6.7.10 MILEAGE MEASUREMENT (Cont'd)**

- F. When jointly provisioned Switched Access Service is provided between the Company and another Exchange Telephone Company in conjunction with 800 DB Access Service and ANI cannot be identified, the Company and the other Exchange Telephone Company will mutually agree upon an end office designation to determine an existing end office that reflects the closest mileage measurement to the average Switched Transport miles. This end office designation can then be used for purposes of determining the appropriate mileage by using the V & H coordinates method. When the ANI can be determined, the originating end office will be used to determine the Switched Transport mileage.
- G. When DTT Switched Transport facilities of different capacities or bandwidths are connected by a multiplexer at a Company Hub, mileage is determined using the V & H coordinates method. Mileage for DTT is measured separately from the SWC to the Company Hub where multiplexing occurs and then measured from the Company Hub to the end office.
- H. When DTT is provided from the SWC to an access tandem in conjunction with TST to subtending end offices, the mileage is determined using the V & H coordinates method. Mileage for DTT is measured between the SWC and the access tandem and mileage for TST is measured from the access tandem to the end offices.
- I. When 800 DB Service is provisioned in conjunction with the Clear Channel Capability optional feature and the 8XX traffic is split so that voice calls are sent via a voice path and data calls are sent via a data path from the same end office to different customer premises locations via TST, Switched Transport access minutes are apportioned between the transmission routes used to provide this feature. When the feature is provided at an access tandem switch, the total Switched Transport access minutes for that end office are apportioned among the trunk groups accessing the end office on the basis of the individual capacity, (i.e., busy hour minutes or number of trunks), ordered for each of those trunk groups. A 30 BHM capacity per trunk is applied when ordered in trunks. This apportionment serves as the basis for the Switched Transport mileage calculation.

**6.7.11 SHARED USE**

The regulations governing the provision of Shared Use facilities are set forth in 2.7, preceding.

**NOTICE**  
**THE INFORMATION CONTAINED IN THIS DOCUMENT IS SUBJECT TO CHANGE.**

**Qwest Corporation**  
**Access Service**  
**Catalog No. 1**

**SECTION 6**  
Page 122  
Release 1  
Effective: 8-1-05

**NORTHERN IDAHO**  
Issued: 7-1-05

---

**6. SWITCHED ACCESS SERVICE**

**6.7 RATE REGULATIONS (Cont'd)**

**6.7.12 TERMINATING FX/ONAL**

When FX/ONAL service is used in the terminating direction to access NXXs outside of the local calling area in which the first point of switching is located, but within the LATA, access rates in this document will not apply. This is Message Toll Service and the rates for Message Toll Service will apply.

**6.7.13 PERCENT DIRECT ROUTED (PDR) FACTOR**

When the customer orders Trunkside Switched Access Service, and the Company is unable to determine routing based on the call detail, the Company apportions usage between TST and DTT based on a state PDR factor. The PDR factor determines the percentage of traffic to be billed TST rates. DTT monthly rates will not be apportioned by the PDR factor.

The Company calculates the PDR factor in the following manner:

Step 1: The Company obtains the total billed usage for all Switched Access Services on a state-wide basis.

Step 2: The Company obtains the total billed usage for all Switched Access Services utilizing TST on a state-wide basis.

Step 3: The percentage of TST traffic is obtained by dividing the total TST billed usage obtained in Step 2 by the total billed usage in Step 1.

Step 4: The percentage in Step 3 is subtracted from 100 to determine the percentage of DTT traffic (PDR factor).

Step 5: The percentage in Step 3 is multiplied by the total number of access minutes that the Company was unable to determine routing for in that specific state.

This PDR factor will serve as the basis for billing until a revised PDR factor is calculated annually based on the previous year's usage.

**NOTICE**  
**THE INFORMATION CONTAINED IN THIS DOCUMENT IS SUBJECT TO CHANGE.**

**Qwest Corporation**  
**Access Service**  
**Catalog No. 1**

**SECTION 6**  
Page 123  
Release 1  
Effective: 8-1-05

**NORTHERN IDAHO**  
Issued: 7-1-05

**6. SWITCHED ACCESS SERVICE**

**6.8 RATES AND CHARGES**

**6.8.1 SWITCHED TRANSPORT**

A. Entrance Facility

	<b>USOC</b>	<b>MONTHLY RATE</b>
1. Voice Grade, per point of termination	EF2AX,FE4AX	\$ 27.25
2. DS1, per DS1	EF2BX,FE4BX	125.00
3. DS3, per DS3	EF2CX,FE4CX	1,350.00
4. Optical Interface[1]		
• DS3, per DS3	EF2DX,FE4DX	943.50

[1] For Shared Use only as set forth in 2.7, preceding.

**NOTICE**  
**THE INFORMATION CONTAINED IN THIS DOCUMENT IS SUBJECT TO CHANGE.**

**Qwest Corporation**  
**Access Service**  
**Catalog No. 1**

**SECTION 6**  
Page 124  
Release 1  
Effective: 8-1-05

**NORTHERN IDAHO**  
Issued: 7-1-05

**6. SWITCHED ACCESS SERVICE**

**6.8 RATES AND CHARGES**

**6.8.1 SWITCHED TRANSPORT (Cont'd)**

B. Direct-Trunked Transport Monthly Rates

MILEAGE BANDS	USOC	MONTHLY RATE	
		FIXED	PER MILE
1. Voice Grade			
0	1YTXA,1UFX1	–	–
Over 0 to 8	1YTXB,1UFX2	\$ 26.00	\$ 0.17
Over 8 to 25	1YTXC,1UFX3	26.00	0.17
Over 25 to 50	1YTXD,1UFX4	26.00	0.17
Over 50	1YTXE,1UFX5	26.00	0.22
2. DS1			
0	1YTXA,1UFX1	–	–
Over 0 to 8	1YTXB,1UFX2	86.50	13.55
Over 8 to 25	1YTXC,1UFX3	111.21	14.38
Over 25 to 50	1YTXD,1UFX4	116.35	14.51
Over 50	1YTXE,1UFX5	130.00	15.05
3. DS3			
0	1YTXA,1UFX1	–	–
Over 0 to 8	1YTXB,1UFX2	724.84	78.90
Over 8 to 25	1YTXC,1UFX3	724.84	78.90
Over 25 to 50	1YTXD,1UFX4	724.84	80.73
Over 50	1YTXE,1UFX5	815.44	91.74

**NOTICE**  
THE INFORMATION CONTAINED IN THIS DOCUMENT IS SUBJECT TO CHANGE.

**Qwest Corporation**  
**Access Service**  
**Catalog No. 1**

**SECTION 6**  
Page 125  
Release 1  
Effective: 8-1-05

**NORTHERN IDAHO**  
Issued: 7-1-05

**6. SWITCHED ACCESS SERVICE**

**6.8 RATES AND CHARGES**

**6.8.1 SWITCHED TRANSPORT (Cont'd)**

C. Tandem-Switched Transport Usage Rates

	<b>RATE PER ACCESS MINUTE FIXED</b>	<b>PER MILE</b>
1. Tandem Transmission		
<b>MILEAGE BANDS</b>		
0	-	-
Over 0 to 8	\$0.000431	\$0.000022
Over 8 to 25	0.000480	0.000023
Over 25 to 50	0.000490	0.000023
Over 50	0.000551	0.000024
		<b>RATE PER ACCESS MINUTE</b>
2. Tandem Switching Charge		\$0.004000

D. Nonrecurring Charges

1. Line or Trunk Installation

	<b>USOC</b>	<b>NONRECURRING CHARGE</b>
• Interface Groups 1 and 2		
- First Line or Trunk	NR61G, FN71G	\$457.00
- Each Additional Line or Trunk	NR61K, FN71K	70.00
• Interface Group 6		
- First Line or Trunk	NR61H, FN71H	438.00
- Each Additional Line or Trunk	NR61L, FN71L	51.00
• Interface Group 9		
- First Line or Trunk	NR61J, FN71J	435.00
- Each Additional Line or Trunk	NR61M, FN71M	48.00

**NOTICE**  
THE INFORMATION CONTAINED IN THIS DOCUMENT IS SUBJECT TO CHANGE.

**Qwest Corporation**  
**Access Service**  
**Catalog No. 1**

**SECTION 6**  
Page 126  
Release 1  
Effective: 8-1-05

**NORTHERN IDAHO**  
Issued: 7-1-05

**6. SWITCHED ACCESS SERVICE**

**6.8 RATES AND CHARGES**

**6.8.1 SWITCHED TRANSPORT**

D. Nonrecurring Charges (Cont'd)

2. Moves Within the Same Serving Wire Center

	USOC	NONRECURRING CHARGE
• Switched Access Service Per Line or Trunk associated with Interface Groups 1 and 2		
- First Line or Trunk	NR6SG,FN7SG	\$348.00
- Each Additional Line or Trunk	NR6SK,FN7SK	28.00
• Switched Access Service Per Line or Trunk associated with Interface Group 6		
- First Line or Trunk	NR6SH,FN7SH	329.00
- Each Additional Line or Trunk	NR6SL,FN7SL	9.00
• Switched Access Service Per Line or Trunk associated with Interface Group 9		
- First Line or Trunk	NR6SJ,FN7SJ	327.00
- Each Additional Line or Trunk	NR6SM,FN7SM	7.00

NOTICE  
THE INFORMATION CONTAINED IN THIS DOCUMENT IS SUBJECT TO CHANGE.

**Qwest Corporation**  
**Access Service**  
**Catalog No. 1**

**SECTION 6**  
Page 127  
Release 1  
Effective: 8-1-05

**NORTHERN IDAHO**  
Issued: 7-1-05

**6. SWITCHED ACCESS SERVICE**

**6.8 RATES AND CHARGES**

**6.8.1 SWITCHED TRANSPORT**

D. Nonrecurring Charges (Cont'd)

3. Moves to a Different Serving Wire Center

	USOC	NONRECURRING CHARGE
• Switched Access Service Per Line or Trunk associated with Interface Groups 1 and 2		
- First Line or Trunk	NR6DG, FN7DG	\$392.00
- Each Additional Line or Trunk	NR6DK, FN7DK	41.00
• Switched Access Service Per Line or Trunk associated with Interface Group 6		
- First Line or Trunk	NR6DH, FN7DH	361.00
- Each Additional Line or Trunk	NR6DL, FN7DL	10.00
• Switched Access Service Per Line or Trunk associated with Interface Group 9		
- First Line or Trunk	NR6DJ, FN7DJ	358.00
- Each Additional Line or Trunk	NR6DM, FN7DM	7.00

NOTICE  
THE INFORMATION CONTAINED IN THIS DOCUMENT IS SUBJECT TO CHANGE.

**Qwest Corporation**  
**Access Service**  
**Catalog No. 1**

**SECTION 6**  
Page 128  
Release 1  
Effective: 8-1-05

**NORTHERN IDAHO**  
Issued: 7-1-05

**6. SWITCHED ACCESS SERVICE**

**6.8 RATES AND CHARGES**

**6.8.1 SWITCHED TRANSPORT**

D. Nonrecurring Charges (Cont'd)

4. Service Rearrangement

a. Multifrequency (MF) to SS7 Out of Band Signaling

(1) Service Order Rearrangement Charge

	USOC	NONRECURRING CHARGE
• MF FGD one-way to SS7 FGD two-way	NR6S1, FN7S1	\$ 99.50
• MF FGD two-way to SS7 FGD two-way	NR6S2, FN7S2	99.50

(2) MF to SS7 Trunk Rearrangement Charge

MF FGD one-way to SS7 FGD two-way

• Per first trunk in a SS7 trunk group		
- Interface Groups 1 and 2	NR61U, FN71U	183.63
- Interface Group 6	NR61V, FN71V	179.66
- Interface Group 9	NR61W, FN71W	179.66
• Per each additional trunk in a SS7 trunk group		
- Interface Groups 1 and 2	NR61X, FN71X	15.46
- Interface Group 6	NR61Y, FN71Y	11.49
- Interface Group 9	NR61Z, FN71Z	11.49

**NOTICE**  
**THE INFORMATION CONTAINED IN THIS DOCUMENT IS SUBJECT TO CHANGE.**

**Qwest Corporation**  
**Access Service**  
**Catalog No. 1**

**SECTION 6**  
Page 129  
Release 1  
Effective: 8-1-05

**NORTHERN IDAHO**  
Issued: 7-1-05

**6. SWITCHED ACCESS SERVICE**

**6.8 RATES AND CHARGES**

**6.8.1 SWITCHED TRANSPORT**

D.4.a.(2) (Cont'd)

MF FGD two-way to SS7 FGD two-way

	<b>USOC</b>	<b>NONRECURRING CHARGE</b>
• Per first trunk in a SS7 trunk group		
- Interface Groups 1 and 2	NR62U, FN72U	\$155.60
- Interface Group 6	NR62V, FN72V	151.63
- Interface Group 9	NR62W, FN72W	151.63
• Per each additional trunk in a SS7 trunk group		
- Interface Groups 1 and 2	NR62X, FN72X	12.62
- Interface Group 6	NR62Y, FN72Y	8.65
- Interface Group 9	NR62Z, FN72Z	8.65
b. FGD Service with SS7 Out of Band Signaling to FGD Service with SS7 Out of Band Signaling and Clear Channel Capability		

	<b>USOC</b>	<b>NONRECURRING CHARGE</b>
• Per first trunk		
- Interface Group 6	NR6RT, FN7RT	\$204.64
- Interface Group 9	NR6RU, FN7RU	203.23
• Per each additional trunk		
- Interface Group 6	NR6RV, FN7RV	22.85
- Interface Group 9	NR6RW, FN7RW	21.65

**NOTICE**  
**THE INFORMATION CONTAINED IN THIS DOCUMENT IS SUBJECT TO CHANGE.**

**Qwest Corporation**  
**Access Service**  
**Catalog No. 1**

**SECTION 6**  
Page 130  
Release 1  
Effective: 8-1-05

**NORTHERN IDAHO**  
Issued: 7-1-05

**6. SWITCHED ACCESS SERVICE**

**6.8 RATES AND CHARGES**

**6.8.1 SWITCHED TRANSPORT (Cont'd)**

E. Optional Features

1. Multiple POTs Tandem Sectorization (MPTS)

	USOC	NONRECURRING CHARGE
• MPTS ASR (without associated trunk activity), per ASR	NR6TA, FN7TA	\$ 48.71
• MPTS Establishment (without associated trunk activity)		
- Per FGC sector	NR6TF, FN7TF	323.25
- Per FGD sector	NR6TB, FN7TB	188.86
• MPTS Establishment (with associated trunk activity)		
- Per FGC sector	NR6TG, FN7TG	323.25
- Per FGD sector	NR6TC, FN7TC	188.86
• MPTS Rearrangement (without associated trunk activity)		
- Per FGC sector	NR6TH, FN7TH	47.25
- Per FGD sector	NR6TD, FN7TD	32.55
• MPTS Rearrangement (with associated trunk activity)		
- Per FGC sector	NR6TJ, FN7TJ	47.25
- Per FGD sector	NR6TE, FN7TE	32.55

**NOTICE**  
THE INFORMATION CONTAINED IN THIS DOCUMENT IS SUBJECT TO CHANGE.

**Qwest Corporation**  
**Access Service**  
**Catalog No. 1**

**SECTION 6**  
Page 131  
Release 1  
Effective: 8-1-05

**NORTHERN IDAHO**  
Issued: 7-1-05

**6. SWITCHED ACCESS SERVICE**

**6.8 RATES AND CHARGES**  
**6.8.1 SWITCHED TRANSPORT**  
E. Optional Features (Cont'd)

		<b>FID</b>
2. Customer specification of the receive transmission level at the first point of switching within a range acceptable to the Company, per Line or Trunk[1]		TLV
3. Customer specification of Switched Transport Termination four-wire termination in lieu of two-wire termination, per Line or Trunk[2]		NC S+T+
	<b>USOC</b>	<b>MONTHLY RATE</b>
4. Multiplexing		
• Entrance Facility, per arrangement		
- DS1 to Voice Grade	MKW1X,FM61X	\$218.40
- DS3 to DS1	MKW3X,FM63X	255.00
• DTT Facility, per arrangement		
- DS1 to Voice Grade	M6W1X,FM6YX	218.40
- DS3 to DS1	M6W3X,FM6ZX	255.00

[1] Available with Interface Groups 2, 6 and 9. The range of transmission levels which may be specified is described in Technical Reference PUB GR-334-CORE.

[2] Available with Feature Group B with Type B.

NOTICE  
THE INFORMATION CONTAINED IN THIS DOCUMENT IS SUBJECT TO CHANGE.

**Qwest Corporation**  
**Access Service**  
**Catalog No. 1**

**SECTION 6**  
Page 132  
Release 1  
Effective: 8-1-05

**NORTHERN IDAHO**  
Issued: 7-1-05

**6. SWITCHED ACCESS SERVICE**

**6.8 RATES AND CHARGES (Cont'd)**

**6.8.2 LOCAL SWITCHING**

A. Local End Office Switching

	<b>RATE PER ACCESS MINUTE</b>	
• LS1 - Feature Groups A & B		\$0.014308
• LS2 - Feature Groups C & D		0.014308
	<b>RATE</b>	
• 800 DB Access Service		
- 800 CIC, per call		\$0.003500
- Vertical Features		
- POTS Translation Charge, per call		0.003665
- Call Handling and Destination Feature Charge, per query		0.000694
• 900 Access Service Customer Identification Charge, per call		0.000994
	<b>USOC</b>	<b>NONRECURRING CHARGE</b>
• 900 Access Service		
- Per first NXX, per End Office/Tandem	N9E	\$ 103.56
- Per each subsequent NXX, per End Office/Tandem	N9G1X	25.11
- Expanded 900 Option per End Office/ Tandem with NXX Activity (available with FGD)	N98AX	988.83
- Expanded 900 Option per End Office/ Tandem without NXX Activity (available with FGD)	N98BX	1,035.25

**NOTICE**  
**THE INFORMATION CONTAINED IN THIS DOCUMENT IS SUBJECT TO CHANGE.**

**Qwest Corporation**  
**Access Service**  
**Catalog No. 1**

**SECTION 6**  
Page 133  
Release 1  
Effective: 8-1-05

**NORTHERN IDAHO**  
Issued: 7-1-05

**6. SWITCHED ACCESS SERVICE**

**6.8 RATES AND CHARGES**

**6.8.2 LOCAL SWITCHING**

A. Local End Office Switching (Cont'd)

1. Common Switching Optional Features

	<b>FID</b>
• Call Denial on Line or Hunt Group (available with FGA), per Line	CAD
• Service Code Denial on Line or Hunt Group (available with FGA), per Line	SCD
• Hunt Group Arrangement (available with FGA), per Line	HML/HTG
• Uniform Call Distribution Arrangement (available with FGA), per Line	HTY UD
• Nonhunting Number for Use with Hunt Group Arrangement or Uniform Call Distribution Arrangement (available with FGA), per Line	NHN
• Automatic Number Identification (available with FGB, FGC and FGD), per Trunk Group[1]	ANI
• Up to 7 Digit Outpulsing of Access Digits to Customer (available with FGB), per Trunk Group	USDO
• Cut-Through (available with FGD), per End Office or Access Tandem	CTO
• Delay Dial Start-Pulsing Signaling (available with FGC), per Trunk Group	DDSP

[1] MF Signaling or SS7 Out of Band Signaling.

**NOTICE**  
**THE INFORMATION CONTAINED IN THIS DOCUMENT IS SUBJECT TO CHANGE.**

**Qwest Corporation**  
**Access Service**  
**Catalog No. 1**

**SECTION 6**  
Page 134  
Release 1  
Effective: 8-1-05

**NORTHERN IDAHO**  
Issued: 7-1-05

**6. SWITCHED ACCESS SERVICE**

**6.8 RATES AND CHARGES**

**6.8.2 LOCAL SWITCHING**

A.1. (Cont'd)

	<b>FID</b>
• Immediate Dial Pulse Address Signaling (available with FGC), per Trunk Group	ADS IDP
• Dial Pulse Address Signaling (available with FGC), per Trunk Group	ADS DP
• Service Class Routing (available with FGC and FGD), per Trunk Group	SCRT
• Multiple Customer Premises Alternate Routing (available with FGB, FGC and FGD), per Trunk Group	ARTG
• End Office Alternate Routing When Ordered in Trunks (available with FGB, FGC and FGD), - Per Trunk - Per Trunk Group	ARTQ
• End Office Alternate Routing to a customer-provided tandem premises, FGD only - Per trunk - Per trunk group	ARTG
• Trunk Access Limitation Arrangement (available with FGC and FGD), per End Office	CHOK
• Band Advance for use with WATS Access Service (available with FGC and FGD), per Hunt or Trunk Group	BAAD
• Hunt Group for use with WATS Access Service (available with FGC and FGD), per Hunt Group	HML/HTG

**NOTICE**  
**THE INFORMATION CONTAINED IN THIS DOCUMENT IS SUBJECT TO CHANGE.**

**Qwest Corporation**  
**Access Service**  
**Catalog No. 1**

**SECTION 6**  
 Page 135  
 Release 1  
 Effective: 8-1-05

**NORTHERN IDAHO**  
 Issued: 7-1-05

**6. SWITCHED ACCESS SERVICE**

**6.8 RATES AND CHARGES**

**6.8.2 LOCAL SWITCHING**

A.1. (Cont'd)

	<b>FID</b>	
<ul style="list-style-type: none"> <li>Uniform Call Distribution for use with WATS Access Service (available with FGC and FGD, per Hunt Group)</li> </ul>	HTY UD	
<ul style="list-style-type: none"> <li>Nonhunting Number for use with Hunt Group or Uniform Call Distribution for use with WATS Access Service (available with FGC and FGD), per Line</li> </ul>	NHN	
	<b>RATE</b>	
<ul style="list-style-type: none"> <li>Feature Group A InterLATA Toll Denial, per Line</li> </ul>	-	
	<b>USOC</b>	<b>NONRECURRING CHARGE</b>
<ul style="list-style-type: none"> <li>Clear Channel Capability (available with FGD), per trunk group</li> </ul>	NR4CA	\$25.00

**NOTICE**  
 THE INFORMATION CONTAINED IN THIS DOCUMENT IS SUBJECT TO CHANGE.

**Qwest Corporation**  
**Access Service**  
**Catalog No. 1**

**SECTION 6**  
Page 136  
Release 1  
Effective: 8-1-05

**NORTHERN IDAHO**  
Issued: 7-1-05

**6. SWITCHED ACCESS SERVICE**

**6.8 RATES AND CHARGES**

**6.8.2 LOCAL SWITCHING**

A. Local End Office Switching (Cont'd)

2. Transport Termination Options

a. Lineside Terminations (For FGA)

	<b>FID</b>
• Two Way Operation	
- Dial Pulse with Loop Start	NC +++A
- Dial Pulse with Ground Start	NC +++E
- DTMF with Loop Start	NC +++F
- DTMF with Ground Start	NC +++G
• Terminating Operation	
- Dial Pulse with Loop Start	NC +++N
- Dial Pulse with Ground Start	NC +++P
- DTMF with Loop Start	NC +++R
- DTMF with Ground Start	NC +++S
• Originating Operation	
- Loop Start	NC +++U
- Ground Start	NC +++V

NOTICE  
THE INFORMATION CONTAINED IN THIS DOCUMENT IS SUBJECT TO CHANGE.

**Qwest Corporation**  
**Access Service**  
**Catalog No. 1**

**SECTION 6**  
Page 137  
Release 1  
Effective: 8-1-05

**NORTHERN IDAHO**  
Issued: 7-1-05

**6. SWITCHED ACCESS SERVICE**

**6.8 RATES AND CHARGES**

**6.8.2 LOCAL SWITCHING**

A.2. (Cont'd)

b. Trunkside Terminations (For FGB, FGC and FGD)

	<b>FID</b>
• Standard Trunk for Originating, (available with FGB, FGC and FGD)	TTC SO
• Terminating (available with FGB, FGC and FGD)	TTC ST
• Two-Way (available with FGB, FGC and FGD)[1]	TTC TY
• Operator Trunk, Coin, Non-Coin or Combined Coin and Non-Coin (available with FGC and FGD)	TTC CO
• Operator Trunk, Full Feature Arrangement (available with FGD)	TTC FF

B. Line Terminations

1. WATS Access Line Termination Options

a. Lineside Terminations:

• Originating Only Loop Start, Lineside Connection, with DTMF Address Signaling, per WATS Access Line	NC +++R
• Originating Only Loop Start, Lineside Connection, with Dial Pulse Address Signaling, per WATS Access Line	NC +++N

[1] Two-Way Trunkside Termination is not available on FGD Service routed via a customer-provided tandem premises.

**Qwest Corporation**  
**Access Service**  
**Catalog No. 1**

**SECTION 6**  
Page 138  
Release 1  
Effective: 8-1-05

**NORTHERN IDAHO**  
Issued: 7-1-05

**6. SWITCHED ACCESS SERVICE**

**6.8 RATES AND CHARGES**

**6.8.2 LOCAL SWITCHING**

B.1.a. (Cont'd)

**FID**

- Originating Only Ground Start,  
Lineside Connection, with  
DTMF Address Signaling,  
per WATS Access Line NC +++S
- Originating Only Ground Start,  
Lineside Connection, with  
Dial Pulse Address Signaling,  
per WATS Access Line NC +++P
- Terminating Only Loop Start,  
Lineside Connection,  
per WATS Access Line NC +++U
- Terminating Only Ground Start,  
Lineside Connection,  
per WATS Access Line NC +++V

b. Trunkside Terminations:

- Terminating Only  
Trunkside Connection  
for Forwarding of Dialed  
Number Identification  
to End User, per  
WATS Access Line NC +++T

**6.8.3 MESSAGE UNIT CREDIT**

**RATE**

- Message Unit Credit, per originating  
access minute[1] (\$ 0.000702)

[1] () Equals a negative amount.

**NOTICE**  
**THE INFORMATION CONTAINED IN THIS DOCUMENT IS SUBJECT TO CHANGE.**

**Qwest Corporation**  
**Access Service**  
**Catalog No. 1**

**SECTION 12**  
Index Page 1  
Release 2  
Effective: 2-1-10

**NORTHERN IDAHO**  
Issued: 1-22-10

**12. ADDITIONAL ENGINEERING, ADDITIONAL LABOR  
AND MISCELLANEOUS SERVICES**

<b>SUBJECT</b>	<b>PAGE</b>
Access Service Billing .....	27
Additional Engineering .....	1
Charges .....	1
Additional Labor .....	2
Charges .....	3
Interexchange Carrier Subscription.....	11
Maintenance of Service.....	4
Miscellaneous Services.....	4
Other Labor .....	2
Overtime Installation.....	2
Provision of Access Service Billing Information.....	27
Switched Access Testing Services.....	16
Tandem Service Provider Bill Data Arrangements.....	33
Telecommunications Service Priority (TSP) System.....	5
Testing Services .....	16

(D)

**Qwest Corporation**  
**Access Service**  
**Catalog No. 1**

**SECTION 12**  
Page 1  
Release 1  
Effective: 8-1-05

**NORTHERN IDAHO**  
Issued: 7-1-05

**12. ADDITIONAL ENGINEERING, ADDITIONAL LABOR  
AND MISCELLANEOUS SERVICES**

In this section, normal business hours are from Monday through Friday, 8:00 a.m. to 5:00 p.m. Hours before 8:00 a.m. and after 5:00 p.m., Monday through Friday, and all day Saturday, are considered overtime. Sundays and Holidays are premium time.

**12.1 ADDITIONAL ENGINEERING**

Additional Engineering will be provided by the Company at the request of the customer only when:

- A customer requests additional technical information after the Company has already provided the technical information normally included on the Design Layout Report (DLR).
- Additional engineering time is incurred by the Company to engineer a customer's request for a customized technical specifications package.

The Company will notify the customer that additional engineering charges, as set forth in A., following, will apply before any additional engineering is undertaken.

**A. Charges for Additional Engineering**

The charges for Additional Engineering are as follows:

	<b>USOC</b>	<b>NONRECURRING CHARGE</b>
Additional Engineering Periods		
• Basic Time, per engineer, each 1/2 hour or fraction thereof	AEQXX	\$30.00
• Overtime, per engineer, each 1/2 hour or fraction thereof	AEQ0X	40.00

**NOTICE**  
**THE INFORMATION CONTAINED IN THIS DOCUMENT IS SUBJECT TO CHANGE.**

**Qwest Corporation**  
**Access Service**  
**Catalog No. 1**

**SECTION 12**  
Page 2  
Release 1  
Effective: 8-1-05

**NORTHERN IDAHO**  
Issued: 7-1-05

**12. ADDITIONAL ENGINEERING, ADDITIONAL LABOR  
AND MISCELLANEOUS SERVICES**

**12.2 ADDITIONAL LABOR**

Additional labor is that labor requested by the customer on a given service and agreed to by the Company as set forth in A. and B., following. The Company will notify the customer that additional labor charges as set forth in C., following, will apply before any additional labor is undertaken. The charges apply per Company technician performing billable work at the customer's request. When more than one technician is involved in working on a customer's request, the amount of time accrued by all technicians will be totaled to determine the number of 1/2 hour increments to be billed.

**A. Overtime Installation**

Overtime installation is that Company installation effort requested by the customer outside of normal business hours.

**B. Other Labor**

Other Labor is that additional labor not included in A., preceding, and labor incurred to accommodate a specific customer request that involves only labor, which is not covered by any other section of this Catalog. Other Labor also includes fine tuning circuits (per occurrence) to return them to the originally designated level even though the circuit has not degraded below the designated immediate action level. In addition, Other Labor includes Testing Services as described in 12.3.4, following.

**NOTICE**  
**THE INFORMATION CONTAINED IN THIS DOCUMENT IS SUBJECT TO CHANGE.**

**Qwest Corporation**  
**Access Service**  
**Catalog No. 1**

**SECTION 12**  
Page 3  
Release 1  
Effective: 8-1-05

**NORTHERN IDAHO**  
Issued: 7-1-05

**12. ADDITIONAL ENGINEERING, ADDITIONAL LABOR  
AND MISCELLANEOUS SERVICES**

**12.2 ADDITIONAL LABOR (Cont'd)**

C. Charges for Additional Labor

The charges for additional labor are as follows:

<b>ADDITIONAL LABOR - INSTALLATION PERIODS</b>	<b>USOC</b>	<b>NONRECURRING CHARGE</b>
• Overtime, per technician, each 1/2 hour or fraction thereof[1]	ALFOX	\$ 9.00
• Premium time, per technician, each 1/2 hour or fraction thereof[1]	ALFPX	17.00

**ADDITIONAL LABOR - OTHER PERIODS**

• Basic time, per technician, each 1/2 hour or fraction thereof	ALGXX	28.00
• Overtime, per technician, each 1/2 hour or fraction thereof[1]	ALGOX	36.00
• Premium time, per technician, each 1/2 hour or fraction thereof[1]	ALGPX	45.00

[1] A call-out of a Company employee at a time not consecutive with the employee's scheduled work period is subject to a minimum charge of four (4) hours.

**NOTICE**  
**THE INFORMATION CONTAINED IN THIS DOCUMENT IS SUBJECT TO CHANGE.**

**Qwest Corporation**  
**Access Service**  
**Catalog No. 1**

**SECTION 12**  
Page 4  
Release 1  
Effective: 8-1-05

**NORTHERN IDAHO**  
Issued: 7-1-05

**12. ADDITIONAL ENGINEERING, ADDITIONAL LABOR  
AND MISCELLANEOUS SERVICES**

**12.3 MISCELLANEOUS SERVICES**

**12.3.1 MAINTENANCE OF SERVICE**

When a customer reports a trouble to the Company for clearance and no trouble is found in the Company's facilities, the customer shall be responsible for payment of a Maintenance of Service charge for the period of time from when Company personnel are dispatched to the customer's premises to when the work is completed. Failure of Company personnel to find trouble in Company facilities will result in no charge if the trouble is actually in those facilities, but not discovered at the time. The customer shall be responsible for payment of a Maintenance of Service charge when the Company dispatches personnel to the customer's premises, and the trouble is in equipment or communications systems provided by other than the Company. No credit allowance will be applicable for the interruption involved if the Maintenance of Service charge applies.

When a Maintenance of Service visit is made, Maintenance of Service Charges will apply and are billed to the customer where the problem exists.

<b>MAINTENANCE OF SERVICE PERIODS</b>	<b>USOC</b>	<b>NONRECURRING CHARGE</b>
• Basic Time, per technician, each 1/2 hour or fraction thereof	MVWXX	\$27.00
• Overtime, per technician, each 1/2 hour or fraction thereof[1]	MVWOX	36.00
• Premium Time, per technician, each 1/2 hour or fraction thereof[1]	MVWPX	45.00

[1] A call-out of a Company employee at a time not consecutive with the employee's scheduled work period is subject to a minimum charge of four hours.

**NOTICE**  
**THE INFORMATION CONTAINED IN THIS DOCUMENT IS SUBJECT TO CHANGE.**

**Qwest Corporation**  
**Access Service**  
**Catalog No. 1**

**SECTION 12**  
Page 5  
Release 1  
Effective: 8-1-05

**NORTHERN IDAHO**  
Issued: 7-1-05

---

**12. ADDITIONAL ENGINEERING, ADDITIONAL LABOR  
AND MISCELLANEOUS SERVICES**

**12.3 MISCELLANEOUS SERVICES (Cont'd)**

**12.3.2 TELECOMMUNICATIONS SERVICE PRIORITY (TSP) SYSTEM**

A. Description

Telecommunications Service Priority (TSP) is a regulatory, administrative, and operational system developed by the Federal Government to ensure priority provisioning and/or restoration of National Security Emergency Preparedness (NSEP) telecommunications services. The Federal Communications Commission (FCC) defines NSEP telecommunications services as those services which are used to maintain a state of readiness or to respond to and manage any event or crisis, which causes or could cause harm to the population, damage to or loss of property, or degrades or threatens the NSEP posture of the United States.

Under the rules of the TSP System, telephone companies are authorized and required to provision and/or restore services with TSP assignments before services without such assignments.

Priority installation and/or restoration of NSEP telecommunications services shall be provided in accordance with Part 64.401, Appendix A, of the Federal Communications Commission's (FCC's) Rules and Regulations.

In addition, TSP System service shall be provided in accordance with the guidelines set forth in "Telecommunications Service Priority (TSP) System for National Security Emergency Preparedness (NSEP) Service Vendor Handbook", (National Communications System (NCS) Handbook 3-1-2) dated December 1, 1989.

**NOTICE**  
**THE INFORMATION CONTAINED IN THIS DOCUMENT IS SUBJECT TO CHANGE.**

**Qwest Corporation**  
**Access Service**  
**Catalog No. 1**

**SECTION 12**  
Page 6  
Release 1  
Effective: 8-1-05

**NORTHERN IDAHO**  
Issued: 7-1-05

**12. ADDITIONAL ENGINEERING, ADDITIONAL LABOR  
AND MISCELLANEOUS SERVICES**

**12.3 MISCELLANEOUS SERVICES**

**12.3.2 TELECOMMUNICATIONS SERVICE PRIORITY (TSP) SYSTEM (Cont'd)**

B. Definitions

Confirmation

Denotes the process required of a prime service vendor to report the completion of TSP service orders to the TSP Program Office.

Invocation

Denotes the notification from an invocation official, conveyed by a service user to a service vendor, that a TSP service is so vital that it must be expeditiously provisioned.

Preemption

Denotes the authorization of the Company by the FCC's TSP System rules to preempt other existing services to restore TSP services when, in the Company's best judgment, preemption is necessary. If no suitable spare or non-TSP services are available, the service vendor may preempt an existing TSP service to restore a TSP service of higher restoration priority assignment.

Prime Service Vendor

Denotes the status of the Company when contracting directly with a service user to provide the user all or a portion of a TSP service.

Reconciliation

Denotes the comparison of TSP service information and the resolution of identified discrepancies.

Service User (TSP)

Denotes any individual or organization (including a service vendor) supported by a telecommunication service for which a TSP assignment has been requested or assigned.

**NOTICE**  
**THE INFORMATION CONTAINED IN THIS DOCUMENT IS SUBJECT TO CHANGE.**

**Qwest Corporation**  
**Access Service**  
**Catalog No. 1**

SECTION 12  
Page 7  
Release 1  
Effective: 8-1-05

**NORTHERN IDAHO**  
Issued: 7-1-05

Effective: 8-1-05

**12. ADDITIONAL ENGINEERING, ADDITIONAL LABOR  
AND MISCELLANEOUS SERVICES**

**12.3 MISCELLANEOUS SERVICES**

**12.3.2 TELECOMMUNICATIONS SERVICE PRIORITY (TSP) SYSTEM**

B. Definitions (Cont'd)

Subcontractor

Denotes the Company as a TSP service vendor with whom a prime service vendor contracts to provide a portion of a service to a TSP service user.

System Development

Denotes the Company's modification of computer software, the development of processes and procedures and the staff training necessary for the provisioning of the TSP System.

Verification

Denotes the procedure for determining the authority of an invocation official and the accuracy and validity of a TSP installation or restoration priority assignment with the TSP Program Office.

NOTICE  
THE INFORMATION CONTAINED IN THIS DOCUMENT IS SUBJECT TO CHANGE.

**Qwest Corporation**  
**Access Service**  
**Catalog No. 1**

**SECTION 12**  
Page 8  
Release 1  
Effective: 8-1-05

**NORTHERN IDAHO**  
Issued: 7-1-05

**12. ADDITIONAL ENGINEERING, ADDITIONAL LABOR  
AND MISCELLANEOUS SERVICES**

**12.3 MISCELLANEOUS SERVICES**

**12.3.2 TELECOMMUNICATIONS SERVICE PRIORITY (TSP) SYSTEM (Cont'd)**

C. Regulations

1. The TSP System's applicability is limited to telecommunication services which the Company can discreetly identify for priority provisioning and/or restoration.
2. The customer subscribing to TSP System Service must also be the customer subscribing to the service with which TSP is associated.
3. Under certain conditions, it may be necessary to preempt one or more customer services with a lower or no restoration priority in order to install or restore higher priority NSEP telecommunications service(s). If such preemption is necessary, and if circumstances permit, the Company will make reasonable effort to notify the preempted customer of the action to be taken. Credit allowance for such service preemption shall be made, in accordance with the provisions specified elsewhere.
4. In obtaining TSP System service, the customer acknowledges and consents to the company providing customer service record information to the Federal Government in order for the Government to maintain and administer its overall TSP System. This customer service record information will include TSP Authorization Code, Company Circuit/Service ID, customer telephone number and service location.
5. Credit allowance for service interruption for Priority Restoration Maintenance and Administration shall be the same as for the service with which it is associated as specified elsewhere.
6. When performing a service under TSP, the Company may not be in a position to notify the customer in advance of circumstances which require additional labor and for which additional labor charges apply. The TSP subscriber recognizes that quoting charges and obtaining permission to proceed would cause unnecessary delays that would be contrary to the objectives of the TSP System. In subscribing to the TSP system the customer recognizes this condition and grants the Company the right to quote charges after work has been completed.
7. Other regulations, rates and charges for services such as expedited service, special construction, due date change, Maintenance of Service etc. may apply as specified elsewhere when provided in conjunction with the TSP System.

**NOTICE**  
**THE INFORMATION CONTAINED IN THIS DOCUMENT IS SUBJECT TO CHANGE.**

**Qwest Corporation**  
**Access Service**  
**Catalog No. 1**

**SECTION 12**  
Page 9  
Release 1  
Effective: 8-1-05

**NORTHERN IDAHO**  
Issued: 7-1-05

**12. ADDITIONAL ENGINEERING, ADDITIONAL LABOR  
AND MISCELLANEOUS SERVICES**

**12.3 MISCELLANEOUS SERVICES**

**12.3.2 TELECOMMUNICATIONS SERVICE PRIORITY (TSP) SYSTEM (Cont'd)**

D. Rates and Charges

The following rates and charges are per point of termination or per access line and apply when the Company is either a Prime Service Vendor or a Subcontractor to a Prime Service Vendor of the TSP System. These rates and charges are in addition to all other rates and charges that may be applicable for services which operate in conjunction with the TSP System.

	<b>USOC</b>	<b>NONRECURRING CHARGE</b>	<b>MONTHLY RATE</b>
Priority Installation (PI)[1]			
• PI Invocation			
Includes System Development, Verification and Confirmation			
- Prime Service Vendor	P1APX	\$128.00	—
- Subcontractor	P1ASX	128.00	—

[1] When a service is ordered with both PI and PR, the associated nonrecurring charge for PR applies.

**NOTICE**  
**THE INFORMATION CONTAINED IN THIS DOCUMENT IS SUBJECT TO CHANGE.**

**Qwest Corporation**  
**Access Service**  
**Catalog No. 1**

**SECTION 12**  
Page 10  
Release 1  
Effective: 8-1-05

**NORTHERN IDAHO**  
Issued: 7-1-05

**12. ADDITIONAL ENGINEERING, ADDITIONAL LABOR  
AND MISCELLANEOUS SERVICES**

**12.3 MISCELLANEOUS SERVICES**

**12.3.2 TELECOMMUNICATIONS SERVICE PRIORITY (TSP) SYSTEM**

D. Rates and Charges (Cont'd)

	USOC	NONRECURRING CHARGE	MONTHLY RATE
Priority Restoration (PR)[1]			
• PR Level Implementation			
Includes System Development, Verification and Confirmation			
- Prime Service Vendor	PR5PX	\$128.00	—
- Subcontractor	PR5SX	128.00	—
• PR Level Change Only			
Includes Verification and Confirmation			
- Prime Service Vendor	PR8PX	5.00	—
- Subcontractor	PR8SX	5.00	—
• PR Maintenance and Administration			
Includes Reconciliation			
- Prime Service Vendor	PR9PX	—	\$1.75
- Subcontractor	PR9SX	—	1.75

[1] When a service is ordered with both PI and PR, the associated nonrecurring charge for PR applies.

**NOTICE**  
**THE INFORMATION CONTAINED IN THIS DOCUMENT IS SUBJECT TO CHANGE.**

**Qwest Corporation**  
**Access Service**  
**Catalog No. 1**

**SECTION 12**  
Page 11  
Release 1  
Effective: 8-1-05

**NORTHERN IDAHO**  
Issued: 7-1-05

**12. ADDITIONAL ENGINEERING, ADDITIONAL LABOR  
AND MISCELLANEOUS SERVICES**

**12.3 MISCELLANEOUS SERVICES (Cont'd)**

**12.3.3 INTEREXCHANGE CARRIER SUBSCRIPTION**

A. Description

Interexchange Carrier (IC) Subscription is a procedure whereby an end user or payphone service provider (PSP) may select and designate to the Company an IC to access without dialing an access code. This procedure applies for both interLATA and intraLATA calls. This IC is referred to as the end user's or PSP's primary IC (PIC). An end user or PSP may select one primary IC for both interLATA and intraLATA service, or they may choose to have two primary ICs, one for interLATA service and a different IC for intraLATA service.

The IC Subscription procedure applies to Telephone Exchange Service lines and/or trunks, Switched Access Lineside connections, Centrex-type lines and Public Access Line (PAL) Service.

- For IC Subscription pay telephones, the PSP will select and designate to the Company an IC to access, without dialing an access code, for intraLATA calls.

Should a caller wish to use the services of an IC other than the primary IC, it is necessary for the caller to dial the IC's access code(s) to reach that IC's service(s).

The terms, conditions, rates and charges for interLATA IC Subscription are found in F.C.C. No. 1, Section 13.

The terms and conditions for intraLATA IC Subscription are following.

B. Terms and Conditions

1. Charge Application for IC Subscription

- a. End users or PSPs placing orders for new service will be asked to select a primary IC at the time they place an order with the Company for Exchange Service, Switched Access Lineside connection, Centrex-type service or PAL Service. There will be no charge for this selection.

**NOTICE**  
**THE INFORMATION CONTAINED IN THIS DOCUMENT IS SUBJECT TO CHANGE.**

**Qwest Corporation**  
Access Service  
Catalog No. 1

SECTION 12  
Page 12  
Release 2  
Effective: 12-31-05

NORTHERN IDAHO  
Issued: 12-29-05

**12. ADDITIONAL ENGINEERING, ADDITIONAL LABOR  
AND MISCELLANEOUS SERVICES**

**12.3 MISCELLANEOUS SERVICES**

**12.3.3 INTEREXCHANGE CARRIER SUBSCRIPTION**

B.1. (Cont'd)

- b. Subsequent to the installation of Telephone Exchange Service, Switched Access Lineside connection, Centrex-type service or PAL Service, for any change in selection, including a change from one access code to another access code for the same IC, a nonrecurring charge applies.
- c. When end users or PSPs simultaneously choose or change an intraLATA and interLATA primary IC, a PIC change charge from F.C.C. No. 1, Section 13, will apply in addition to the applicable charge as set forth in D., following. (T)  
(C)
- d. The nonrecurring charge for a primary IC change is billed to the end user who is the subscriber to the Telephone Exchange Service, Switched Access Lineside connection, Centrex-type service or to the PSP of PAL Service. However, an IC may, at its option, pay the charge for any end user and/or PSP at any time, or as prescribed by the Company, when the IC has specified that the PIC change request is being made as the result of an end user/PSP disputed PIC change reported to the alleged authorized carrier. The nonrecurring charge for a PIC change is set forth in D., following.
- e. The applicable primary IC change charge as set forth in D., following, will be determined based on whether the change is requested through manual or electronic means. (N)  
  - (1) A manual change is defined as a change submitted to a customer service representative from an end user request or by a wholesale provider request.
  - (2) An electronic change is defined as a change submitted by an IC to the Company through the Regional Subscription System (RSS) or processed from an electronic source such as a Company-sponsored website, regardless of whether some manual processing is required. (N)  
(M)

(M) Material moved to Page 12.1.

**Qwest Corporation**  
Access Service  
Catalog No. 1

SECTION 12  
Page 12.1  
Release 1  
Effective: 12-31-05

**NORTHERN IDAHO**  
Issued: 12-29-05

---

**12. ADDITIONAL ENGINEERING, ADDITIONAL LABOR  
AND MISCELLANEOUS SERVICES**

**12.3 MISCELLANEOUS SERVICES**

**12.3.3 INTEREXCHANGE CARRIER SUBSCRIPTION**

**B. Terms and Conditions (Cont'd)**

**2. Dispute Application for IC Subscription**

If there is a conflict between an end user, a PSP or their respective agent, on one hand, and the IC on the other hand, over the designation of the primary IC, the Company will honor the designation selected by the end user, a PSP or their respective agent, regardless of any contractual obligations the end user, PSP or agent may have with one or more ICs.

If there is a conflict between an end user and/or a PSP, on one hand, and their agent on the other hand, over the designation of the primary IC, the Company will honor the designation selected by the end user and/or PSP regardless of any contractual obligations the end user and/or PSP may have with one or more ICs or agents.

(M)

(M)

(M) Material moved from Page 12.

NOTICE  
THE INFORMATION CONTAINED IN THIS DOCUMENT IS SUBJECT TO CHANGE.

**Qwest Corporation**  
**Access Service**  
**Catalog No. 1**

SECTION 12  
Page 13  
Release 1  
Effective: 8-1-05

**NORTHERN IDAHO**  
Issued: 7-1-05

---

**12. ADDITIONAL ENGINEERING, ADDITIONAL LABOR  
AND MISCELLANEOUS SERVICES**

**12.3 MISCELLANEOUS SERVICES**

**12.3.3 INTEREXCHANGE CARRIER SUBSCRIPTION**

B. Terms and Conditions (Cont'd)

3. Subscriber Alleged PIC Disputes

When a subscriber alleges that a PIC change was made without their authorization, the Company shall return the subscriber to their previous PIC at no charge to the subscriber. All PIC change charges assessed by the Company to the subscriber as the result of the alleged unauthorized PIC change shall be credited to the subscriber's service.

Even if no order is received from the alleged unauthorized carrier to switch the customer back to their alleged authorized carrier, the Company will assess two nonrecurring PIC change charges to the alleged unauthorized carrier, one for the initial switch of the subscriber to the alleged unauthorized carrier; the second for the switch from the alleged unauthorized carrier to the alleged authorized carrier as set forth in D., following.

If the alleged unauthorized carrier change was due to a Company error, the subscriber will be returned to the alleged authorized carrier free of charge to both the subscriber and the alleged unauthorized carrier.

**NOTICE**  
**THE INFORMATION CONTAINED IN THIS DOCUMENT IS SUBJECT TO CHANGE.**

**Qwest Corporation**  
**Access Service**  
**Catalog No. 1**

**SECTION 12**  
Page 14  
Release 1  
Effective: 8-1-05

**NORTHERN IDAHO**  
Issued: 7-1-05

---

**12. ADDITIONAL ENGINEERING, ADDITIONAL LABOR  
AND MISCELLANEOUS SERVICES**

**12.3 MISCELLANEOUS SERVICES**

**12.3.3 INTEREXCHANGE CARRIER SUBSCRIPTION**

B. Terms and Conditions (Cont'd)

4. Cancellation of Interexchange Participation for IC Subscription

If an IC elects to discontinue all of its Feature Group D service in an end office prior to the conversion date or after the introduction of Feature Group D in the converting end office, the IC is obligated to do the following:

- Notify the Company of the cancellation of their Feature Group D service, and;
- Contact all end users or PSPs that are presubscribed to the canceling IC as their primary IC. Inform these end users or PSPs of the cancellation and request that the end users or PSPs contact the Company to select a new primary IC.

The Company will bill the canceling IC the service order charge described in C., following, for each end user or PSP that this IC has currently predesignated to them.

Such charge will not apply to the canceling IC where the canceling IC transfers or assigns its Feature Group D services and the associated 101XXXX code to another IC in such a manner that the Company does not change the end users' or PSPs' records or the end users' or PSPs' PIC designation, or if another IC elects to pay the service order charge on behalf of the canceling IC.

C. IC Initiated Conversions for IC Subscription

When an IC requests that their end user or PSP be changed from one access code to another access code on a mass conversion basis, (e.g., an IC using two or more PIC designations or an IC assuming ownership of another IC's end users, etc.), charges will be as set forth in D., following.

**NOTICE**  
**THE INFORMATION CONTAINED IN THIS DOCUMENT IS SUBJECT TO CHANGE.**

**Qwest Corporation**  
Access Service  
Catalog No. 1

SECTION 12  
Page 15  
Release 2  
Effective: 12-31-05

NORTHERN IDAHO  
Issued: 12-29-05

**12. ADDITIONAL ENGINEERING, ADDITIONAL LABOR  
AND MISCELLANEOUS SERVICES**

**12.3 MISCELLANEOUS SERVICES**

**12.3.3 INTEREXCHANGE CARRIER SUBSCRIPTION (Cont'd)**

D. Rates and Charges

	USOC	NONRECURRING CHARGE	(C)
1. The charges for a Manual PIC change are as follows:			
• Per Telephone Exchange Service line or trunk	P6XLX	\$5.50(I)	
• Per Switched Access Lineside connection	P6XLX	5.50	
• Per Centrex-type line	P6XLX	5.50	
• Per PAL	P6XLX	5.50(I)	
2. The charges for an Electronic PIC change are as follows:			(N)
• Per Telephone Exchange Service line or trunk	P6AFX	1.25	
• Per Switched Access Lineside connection	P6AFX	1.25	
• Per Centrex-type line	P6AFX	1.25	
• Per PAL	P6AFX	1.25	
3. The charges for a simultaneous Manual PIC change are as follows[1]:			
• Per Telephone Exchange Service line or trunk	P6XPX	2.75	
• Per Switched Access Lineside connection	P6XPX	2.75	
• Per Centrex-type line	P6XPX	2.75	
• Per PAL	P6XPX	2.75	
4. The charges for a simultaneous Electronic PIC change are as follows[1]:			
• Per Telephone Exchange Service line or trunk	P6XOX	0.62	
• Per Switched Access Lineside connection	P6XOX	0.62	
• Per Centrex-type line	P6XOX	0.62	
• Per PAL P6XOX		0.62	
5. The charges for an IC Initiated Conversion are as follows:			(T)
• Per Telephone Exchange Service line or trunk		0.75	
• Per Switched Access Lineside connection		0.75	
• Per Centrex-type line		0.75	
• Per PAL		0.75	

[1] Simultaneous Manual and Electronic PIC Charges will apply in addition to the charges described in 12.3.3.B.1.c., preceding. (N)  
(N)

NOTICE  
THE INFORMATION CONTAINED IN THIS DOCUMENT IS SUBJECT TO CHANGE.

**Qwest Corporation**  
**Access Service**  
**Catalog No. 1**

**SECTION 12**  
Page 16  
Release 1  
Effective: 8-1-05

**NORTHERN IDAHO**  
Issued: 7-1-05

**12. ADDITIONAL ENGINEERING, ADDITIONAL LABOR  
AND MISCELLANEOUS SERVICES**

**12.3 MISCELLANEOUS SERVICES (Cont'd)**

**12.3.4 TESTING SERVICES**

Testing Services offered under this section of the Catalog are optional and subject to rates and charges as set forth in B., following, except for Additional Cooperative Acceptance Testing and Nonscheduled Testing, which are subject to the charges, as set forth for Additional Labor - Other, in 12.2.C.2., preceding. Other testing services provided by the Company in association with Access Services are furnished at no additional charge. These other testing services are described in 6.1.4, preceding.

Testing Services are normally provided by Company personnel at Company locations. However, provisions are made in A., following, for a customer to request Company personnel to perform testing services at the customer's premises.

The offering of Testing Services under this section is made subject to the availability of the necessary qualified personnel and test equipment at the various test locations mentioned in A. and B., following:

**A. Switched Access Service**

Testing Services for Switched Access Service are comprised of (a) tests which are performed during the installation of a Switched Access Service, and (b) tests which are performed after acceptance of such access services by a customer, i.e., in-service tests. These in-service tests may be further divided into two broad categories of tests: scheduled and nonscheduled.

Scheduled tests are those tests performed by the Company on a regular basis, e.g., monthly, which result in the measurement of Switched Access Service. Scheduled tests may be done on an automatic basis (no Company or customer technicians involved), on a cooperative basis (Company technician(s) involved at Company office(s) and customer technician(s) involved at customer's premises), or a manual basis (Company technician(s) involved at Company office(s) and at customer's premises).

Nonscheduled tests are performed by the Company "on demand", which result in the measurement of Switched Access Services. Nonscheduled tests may involve Company technicians at Company offices and at the customer's premises.

**NOTICE**  
**THE INFORMATION CONTAINED IN THIS DOCUMENT IS SUBJECT TO CHANGE.**

**Qwest Corporation**  
**Access Service**  
**Catalog No. 1**

**SECTION 12**  
Page 17  
Release 1  
Effective: 8-1-05

**NORTHERN IDAHO**  
Issued: 7-1-05

**12. ADDITIONAL ENGINEERING, ADDITIONAL LABOR  
AND MISCELLANEOUS SERVICES**

**12.3 MISCELLANEOUS SERVICES**

**12.3.4 TESTING SERVICES**

A. Switched Access Service (Cont'd)

1. Additional Cooperative Acceptance Testing (ACAT)

Additional Cooperative Acceptance Testing (ACAT) of Switched Access Service involves the Company provision of a technician at its office(s) and the customer provides a technician at its premises, with suitable test equipment to perform the required tests.

Additional Cooperative Acceptance Tests may, for example, consist of the following tests:

- Impulse Noise
- Phase Jitter
- Signal to C-Notched Noise Ratio
- Intermodulation (Nonlinear) Distortion
- Frequency Shift (Offset)
- Envelope Delay Distortion
- Dial Pulse Percent Break

2. Automatic Scheduled Testing (AST)

Automatic Scheduled Testing (AST) of Switched Access Services (Feature Groups B, C and D), where the customer provides remote office test lines and 105 test lines with associated responders or their functional equivalent, will consist of monthly loss and C-message noise tests and annual balance test. However, the customer may specify a more frequent schedule of tests. In addition to the loss/noise/balance tests, the customer may also order, at additional charges, gain-slope and C-notched noise testing.

The Company will provide a monthly AST report that lists the test results for each trunk tested. Trunk test failures requiring customer participation for trouble resolution will be provided to the customer on an as-occurs basis.

**NOTICE**  
**THE INFORMATION CONTAINED IN THIS DOCUMENT IS SUBJECT TO CHANGE.**

**Qwest Corporation**  
**Access Service**  
**Catalog No. 1**

**SECTION 12**  
Page 18  
Release 1  
Effective: 8-1-05

**NORTHERN IDAHO**  
Issued: 7-1-05

---

**12. ADDITIONAL ENGINEERING, ADDITIONAL LABOR  
AND MISCELLANEOUS SERVICES**

**12.3 MISCELLANEOUS SERVICES**

**12.3.4 TESTING SERVICES**

A. Switched Access Service (Cont'd)

3. Cooperative Scheduled Testing (CST)

Cooperative Scheduled Testing (CST) of Switched Access Services (Feature Groups B, C and D not routed through an access tandem), where the Company provides a technician at its office(s) and the customer provides a technician at its premises, with suitable test equipment to perform the required tests, will consist of quarterly loss and C-message noise tests, and annual balance tests. However, the customer may specify a more frequent schedule of tests. In addition to the loss/noise/balance measurements, the customer may also order, at additional charges, gain-slope and C-notched noise testing.

The Company will provide, on a quarterly basis, a CST report that lists the test results for each trunk tested. Trunk test failures requiring customer participation for trouble resolution will be provided to the customer on an as-occurs basis.

4. Manual Scheduled Testing (MST)

Manual Scheduled Testing (MST) of Switched Access Services (Feature Groups B and D not routed through an access tandem), where the Company provides a technician at its office(s) and at the customer's premises, will consist of quarterly loss and C-message noise tests, and annual balance tests. However, the customer may specify a more frequent schedule of tests. In addition to the loss/noise/balance tests, the customer may also order, at additional charges, gain-slope and C-notched noise testing.

The Company will provide, on a quarterly basis, an MST report that lists the test results for each trunk tested. Trunk test failures requiring customer participation for trouble resolution will be provided to the customer on an as-occurs basis.

**NOTICE**  
**THE INFORMATION CONTAINED IN THIS DOCUMENT IS SUBJECT TO CHANGE.**

**Qwest Corporation**  
**Access Service**  
**Catalog No. 1**

**SECTION 12**  
Page 19  
Release 1  
Effective: 8-1-05

**NORTHERN IDAHO**  
Issued: 7-1-05

**12. ADDITIONAL ENGINEERING, ADDITIONAL LABOR  
AND MISCELLANEOUS SERVICES**

**12.3 MISCELLANEOUS SERVICES**

**12.3.4 TESTING SERVICES**

A. Switched Access Service (Cont'd)

5. Nonscheduled Testing (NST)

Nonscheduled Testing (NST) of Switched Access Services is where:

- The customer provides remote office test lines and 105 test lines with associated responders or their functional equivalent ("automatic testing"), or
- The Company provides a technician at its office(s) and the customer provides a technician at its premises, with suitable test equipment to perform the required tests ("cooperative testing"), or
- The Company provides a technician at its office(s), and/or at the customer's premises with suitable test equipment to perform the required tests ("manual testing").

Nonscheduled Tests may consist of any tests, e.g., loss, noise, slope, envelope delay, which the customer may require.

6. Obligations of the Customer

- a. The customer shall provide the Remote Office Test Line priming data to the Company, as appropriate, to support AST as set forth in 12.3.4.A.2., preceding, or NST as set forth in 12.3.4.A.5., preceding.
- b. The customer shall make the facilities to be tested available to the Company at times mutually agreed upon.

**NOTICE**  
**THE INFORMATION CONTAINED IN THIS DOCUMENT IS SUBJECT TO CHANGE.**

**Qwest Corporation**  
**Access Service**  
**Catalog No. 1**

**SECTION 12**  
Page 20  
Release 1  
Effective: 8-1-05

**NORTHERN IDAHO**  
Issued: 7-1-05

Effective: 8-1-05

---

**12. ADDITIONAL ENGINEERING, ADDITIONAL LABOR  
AND MISCELLANEOUS SERVICES**

**12.3 MISCELLANEOUS SERVICES**

**12.3.4 TESTING SERVICES (Cont'd)**

B. Rates and Charges

1. Switched Access

a. Additional Cooperative Acceptance Testing (ACAT)

The charges for Additional Cooperative Acceptance Testing are specified in 12.2.C.2., preceding, for Additional Labor - Other Periods.

NOTICE  
THE INFORMATION CONTAINED IN THIS DOCUMENT IS SUBJECT TO CHANGE.

**Qwest Corporation**  
**Access Service**  
**Catalog No. 1**

**SECTION 12**  
Page 21  
Release 1  
Effective: 8-1-05

**NORTHERN IDAHO**  
Issued: 7-1-05

**12. ADDITIONAL ENGINEERING, ADDITIONAL LABOR  
AND MISCELLANEOUS SERVICES**

**12.3 MISCELLANEOUS SERVICES**

**12.3.4 TESTING SERVICES**

B.1. (Cont'd)

b. Automatic Scheduled Testing (AST)

The three tests as set forth following represent the minimum offering i.e., an order for testing must, at a minimum, consist of twelve (12) 1004 Hz Loss Tests per transmission path, twelve (12) C-Message Noise Tests per transmission path and one (1) Return Loss (Balance) Test per transmission path, per year. The Additional Tests as set forth following may be ordered by the customer, at additional charges, 60 days prior to the start of the customer prescribed schedule. The customer also may specify a more frequent schedule of tests 60 days prior to the start of the customer prescribed schedule.

	<b>USOC</b>	<b>MONTHLY RATE</b>
(1) To First Point of Switching		
• Basic Tests[1]		
- 1004 Hz Loss Tests performed within a one year period, per test ordered, per transmission path	UBGX+	\$0.02
- C-Message Noise Tests performed within a one year period, per test ordered, per transmission path	UBGX+	0.02
- Return Loss (Balance) Tests performed within a one year period, per test ordered, per transmission path	UBGX+	0.04

[1] Subject to a one year minimum contract period, and annually thereafter.

**NOTICE**  
**THE INFORMATION CONTAINED IN THIS DOCUMENT IS SUBJECT TO CHANGE.**

**Qwest Corporation**  
**Access Service**  
**Catalog No. 1**

**SECTION 12**  
 Page 22  
 Release 1  
 Effective: 8-1-05

**NORTHERN IDAHO**  
 Issued: 7-1-05

**12. ADDITIONAL ENGINEERING, ADDITIONAL LABOR  
 AND MISCELLANEOUS SERVICES**

**12.3 MISCELLANEOUS SERVICES**

**12.3.4 TESTING SERVICES**

B.1.b.(1) (Cont'd)

	<b>USOC</b>	<b>MONTHLY RATE</b>
• Additional Tests		
- Gain-Slope Tests performed within a one year period, per test ordered, per transmission path	UBGX+	\$0.02
- C-Notched Noise Tests performed within a one year period, per test ordered, per transmission path	UBGX+	0.02

EXAMPLE:

A customer schedules thirteen (13) 1004 Hz Loss Tests, thirteen (13) C-Message Noise Tests and two (2) Return Loss Tests on one trunk for a year. The charges will be computed as follows:

$$\begin{array}{r}
 13 \times \$0.02 = \$0.26 \\
 + 13 \times 0.02 = 0.26 \\
 + 2 \times 0.04 = \underline{0.08} \\
 \hline
 \$0.60 \text{ per month, per trunk}
 \end{array}$$

c. Cooperative Scheduled Testing (CST)

The three (3) tests as set forth following represent the minimum offering, i.e., an order for testing must, at a minimum, consist of four (4) 1004 Hz Loss Tests per transmission path, four (4) C-Message Noise Tests per transmission path and one (1) Return Loss (Balance) Test per transmission path, per year. The Additional Tests as set forth following may be ordered by the customer, at additional charges, 60 days prior to the start of the customer prescribed schedule. The customer also may specify a more frequent schedule of tests 60 days prior to the start of the customer prescribed schedule.

**Qwest Corporation**  
**Access Service**  
**Catalog No. 1**

**SECTION 12**  
Page 23  
Release 1  
Effective: 8-1-05

**NORTHERN IDAHO**  
Issued: 7-1-05

**12. ADDITIONAL ENGINEERING, ADDITIONAL LABOR  
AND MISCELLANEOUS SERVICES**

**12.3 MISCELLANEOUS SERVICES**

**12.3.4 TESTING SERVICES**

B.1.c. (Cont'd)

	<b>USOC</b>	<b>MONTHLY RATE</b>
(1) To First Point of Switching		
• Basic Tests[1]		
- 1004 Hz Loss Tests performed within a one year period, per test ordered, per transmission path	UBSX+	\$0.07
- C-Message Noise Tests performed within a one year period, per test ordered, per transmission path	UBSX+	0.07
- Return Loss (Balance) Tests performed within a one year period, per test ordered, per transmission path	UBSX+	0.24
• Additional Tests		
- Gain-Slope Tests performed within a one year period, per test ordered, per transmission path	UBSX+	0.07
- C-Notched Noise Tests performed within a one year period, per test ordered, per transmission path	UBSX+	0.07

[1] Subject to a one year minimum contract period, and annually thereafter.

**NOTICE**  
**THE INFORMATION CONTAINED IN THIS DOCUMENT IS SUBJECT TO CHANGE.**

**Qwest Corporation**  
**Access Service**  
**Catalog No. 1**

**SECTION 12**  
Page 24  
Release 1  
Effective: 8-1-05

**NORTHERN IDAHO**  
Issued: 7-1-05

**12. ADDITIONAL ENGINEERING, ADDITIONAL LABOR  
AND MISCELLANEOUS SERVICES**

**12.3 MISCELLANEOUS SERVICES**

**12.3.4 TESTING SERVICES**

B.1.c. (Cont'd)

EXAMPLE:

A customer schedules six (6) 1004 Hz Loss Tests, six (6) C-Message Noise Tests and four (4) Return Loss Tests on one trunk for a year. The charges will be computed as follows:

$$\begin{array}{r} 6 \times \$0.07 = \$0.42 \\ + 6 \times 0.07 = 0.42 \\ + 4 \times 0.24 = \underline{0.96} \\ \$1.80 \text{ per month, per trunk} \end{array}$$

d. Manual Scheduled Testing (MST)

The three (3) tests as set forth following represent the minimum offering, i.e., an order for testing must, at a minimum, consist of four (4) 1004 Hz Loss Tests per transmission path, four (4) C-Message Noise Tests per transmission path and one (1) Return Loss (Balance) Test per transmission path, per year. The Additional Tests as set forth following may be ordered by the customer, at additional charges, 60 days prior to the start of the customer prescribed schedule. The customer also may specify a more frequent schedule of tests 60 days prior to the start of the customer prescribed schedule.

**NOTICE**  
**THE INFORMATION CONTAINED IN THIS DOCUMENT IS SUBJECT TO CHANGE.**

**Qwest Corporation**  
**Access Service**  
**Catalog No. 1**

**SECTION 12**  
Page 25  
Release 1  
Effective: 8-1-05

**NORTHERN IDAHO**  
Issued: 7-1-05

**12. ADDITIONAL ENGINEERING, ADDITIONAL LABOR  
AND MISCELLANEOUS SERVICES**

**12.3 MISCELLANEOUS SERVICES**

**12.3.4 TESTING SERVICES**

B.1.d. (Cont'd)

	<b>USOC</b>	<b>MONTHLY RATE</b>
(1) To First Point of Switching		
• Basic Tests[1]		
- 1004 Hz Loss Tests performed within a one year period, per test ordered, per transmission path	UBMX+	\$0.14
- C-Message Noise Tests performed within a one year period, per test ordered, per transmission path	UBMX+	0.14
- Return Loss (Balance) Tests performed within a one year period, per test ordered, per transmission path	UBMX+	0.49
• Additional Tests		
- Gain-Slope Tests performed within a one year period, per test ordered, per transmission path	UBMX+	0.12
- C-Notched Noise Tests performed within a one year period, per test ordered, per transmission path	UBMX+	0.12

EXAMPLE:

See B.1.c., preceding

[1] Subject to a one year minimum contract period, and annually thereafter.

**NOTICE**  
**THE INFORMATION CONTAINED IN THIS DOCUMENT IS SUBJECT TO CHANGE.**

**Qwest Corporation**  
**Access Service**  
**Catalog No. 1**

SECTION 12  
Page 26  
Release 1  
Effective: 8-1-05

**NORTHERN IDAHO**  
Issued: 7-1-05

**12. ADDITIONAL ENGINEERING, ADDITIONAL LABOR  
AND MISCELLANEOUS SERVICES**

**12.3 MISCELLANEOUS SERVICES**

**12.3.4 TESTING SERVICES**

B.1. (Cont'd)

e. Nonscheduled Testing (NST)

	USOC	NONRECURRING CHARGE
(1) To First Point of Switching		
Automatic Testing:		
• 1004 Hz Loss, per test performed	USCX+	\$0.35
• C-Message Noise, per test performed	USCX+	0.35
• Return Loss (Balance), per test performed	USCX+	0.57
• Gain-Slope, per test performed	USCX+	0.35
• C-Notched Noise, per test performed	USCX+	0.35

(2) Cooperative Testing:

The charges for Cooperative Testing are specified in 12.2.C.2., preceding, for Additional Labor-Other Periods.

(3) Manual Testing:

The charges for Manual Testing are specified in 12.2.C.2., preceding, for Additional Labor-Other Periods.

**NOTICE**  
**THE INFORMATION CONTAINED IN THIS DOCUMENT IS SUBJECT TO CHANGE.**

**Qwest Corporation**  
**Access Service**  
**Catalog No. 1**

**SECTION 12**  
Page 27  
Release 1  
Effective: 8-1-05

**NORTHERN IDAHO**  
Issued: 7-1-05

**12. ADDITIONAL ENGINEERING, ADDITIONAL LABOR  
AND MISCELLANEOUS SERVICES**

**12.3 MISCELLANEOUS SERVICES (Cont'd)**

**12.3.5 PROVISION OF ACCESS SERVICE BILLING INFORMATION**

- A. The customer will receive its monthly bills in a standard paper format.
- B. At the option of the customer, and for an additional charge:
  - 1. Customer monthly bills may be provided on magnetic tape,
  - 2. Billing detail and/or information may be transmitted to the customer premises by data transmission,
  - 3. Additional copies of the customer monthly bill or service and features record may be provided in standard paper or microfiche format.
- C. Upon acceptance by the Company of an order for data transmission, the Company will determine the period of time to implement the transmission of such material on an individual order basis.
- D. The rates and charges for the provision of Access Service Billing Information are as follows:

	<b>FID</b>	<b>RATES</b>
1. Provision of Standard Billing Detail and/or Information in magnetic tape format, per record	DMT	\$0.0095

**NOTICE**  
**THE INFORMATION CONTAINED IN THIS DOCUMENT IS SUBJECT TO CHANGE.**

**Qwest Corporation**  
**Access Service**  
**Catalog No. 1**

**SECTION 12**  
Page 28  
Release 1  
Effective: 8-1-05

**NORTHERN IDAHO**  
Issued: 7-1-05

**12. ADDITIONAL ENGINEERING, ADDITIONAL LABOR  
AND MISCELLANEOUS SERVICES**

**12.3 MISCELLANEOUS SERVICES**

**12.3.5 PROVISION OF ACCESS SERVICE BILLING INFORMATION**

D. (Cont'd)

	<b>FID</b>	<b>RATES</b>
2. Data Transmission to a customer's premises of Billing Detail and/or Information, per record transmitted	BOD DT	ICB
3. Additional copies of the customer's monthly bill or service and features record in standard paper or microfiche format, per page, per microfiche record	NOB NEL BOD FH	ICB

**NOTICE**  
**THE INFORMATION CONTAINED IN THIS DOCUMENT IS SUBJECT TO CHANGE.**

**Qwest Corporation**  
Access Service  
Catalog No. 1

SECTION 12  
Page 29

NORTHERN IDAHO  
Issued: 1-22-10

Release 2[1]  
Effective: 2-1-10

---

**12. ADDITIONAL ENGINEERING, ADDITIONAL LABOR  
AND MISCELLANEOUS SERVICES**

**12.3 MISCELLANEOUS SERVICES (Cont'd)**

**12.3.6 RESERVED FOR FUTURE USE**

(C)

(D)

(D)

[1] This page cancels pages 30 through 32, Release 1.

(N)

NOTICE  
THE INFORMATION CONTAINED IN THIS DOCUMENT IS SUBJECT TO CHANGE.  
TRANSMITTAL NO. 10-03-NID

**Qwest Corporation**  
**Access Service**  
**Catalog No. 1**

**SECTION 12**  
Page 33  
Release 1  
Effective: 8-1-05

**NORTHERN IDAHO**  
Issued: 7-1-05

**12. ADDITIONAL ENGINEERING, ADDITIONAL LABOR  
AND MISCELLANEOUS SERVICES**

**12.3 MISCELLANEOUS SERVICES (Cont'd)**

**12.3.7 TANDEM SERVICE PROVIDER BILL DATA ARRANGEMENTS**

The Company will provide a bill data arrangement for TSP's requesting the Company to bill FGD terminating usage and nonrecurring charges to the TSP's IC customer.

**A. General Terms and Conditions**

1. When the customer requests the Company to establish a bill data arrangement for FGD terminating usage and/or nonrecurring charges, the Company will provide the TSP's customer with an Access Service bill and customer service record using standards determined by the Company. The IC customer will be billed for all recurring usage rate elements (e.g., LS and CCL) associated with the terminating usage from the TSP's bill data exchange.
2. The Company, in order to safeguard its interests, will require the TSP and the TSP's customer to comply with the provisions of this document.

**B. Terminating Usage Exchange from the TSP to the Company**

1. Terminating FGD data from the TSP to the Company shall be exchanged by billing tape or electronic data transfer using standards determined by the Company to be compatible with the Company's bill processing system(s). The bill data received by the Company must be formatted using the Exchange Message Interface (EMI) format as delineated in Technical Reference PUB SR-320.
2. The TSP is responsible for ensuring accurate and complete terminating call detail records by IC carrier identification code are provided to the Company on a daily basis. The TSP will send the bill data sequentially numbered to the Company-designated processing center. The bill data will be processed by the Company in sequential order. The Company will notify the customer when the bill data is not received in sequential order and/or if the bill data can not be processed.

**NOTICE**  
**THE INFORMATION CONTAINED IN THIS DOCUMENT IS SUBJECT TO CHANGE.**

**Qwest Corporation**  
**Access Service**  
**Catalog No. 1**

**SECTION 12**  
Page 34  
Release 1  
Effective: 8-1-05

**NORTHERN IDAHO**  
Issued: 7-1-05

**12. ADDITIONAL ENGINEERING, ADDITIONAL LABOR  
AND MISCELLANEOUS SERVICES**

**12.3 MISCELLANEOUS SERVICES**

**12.3.7 TANDEM SERVICE PROVIDER BILL DATA ARRANGEMENTS**

**B. Terminating Usage Exchange from the TSP to the Company (Cont'd)**

3. The Company will work cooperatively with the customer to ensure accurate and timely bill data is received within seven calendar days of the call record date. The Company reserves the right to bill the Company-recorded terminating usage directly to the TSP when the TSP is unable to provide accurate and timely billing data to the Company. The Company will bill the Company-recorded terminating usage directly to the TSP for those call record dates not received and/or processed, by end office, on a monthly bill processing basis.

**C. Bill Data Arrangement Dispute and Audit Procedures**

1. In the event of a terminating FGD usage billing dispute, the TSP's customer must submit a documented claim to the TSP. In the event the TSP needs the Company to assist in the resolution of the billing dispute, the TSP must submit to the Company a documented claim by end office per IC billing account number. The Company will work cooperatively with the TSP to resolve the claim in accordance with 2.4.1, preceding.
2. The TSP must retain call detail records submitted to the Company for fifteen months (15) after submission of the bill data to the Company. The Company reserves the right to audit the bill data information upon written notification to the TSP. If the Company requests to audit the TSP's bill data records, the Company will mutually negotiate the audit procedures and responsible party(ies) for payment of audit expenses with the customer.

**NOTICE**  
**THE INFORMATION CONTAINED IN THIS DOCUMENT IS SUBJECT TO CHANGE.**

**Qwest Corporation**  
**Access Service**  
**Catalog No. 1**

**SECTION 15**  
Index Page 1  
Release 2  
Effective: 8-9-08

**NORTHERN IDAHO**  
Issued: 7-30-08

**15. COMMON CHANNEL SIGNALING NETWORK (CCSN)**

<b>SUBJECT</b>	<b>PAGE</b>	
Call Set-Up.....	8	(N)
CCSAC Acceptance Testing Requirements.....	7	
CCSAC Additional Cooperative Acceptance Testing Requirements.....	7	
CCSAC Network Management.....	5	
CCSAC Ordering Requirements.....	5	
CCSAC Performance Requirements.....	6	
CCSAC Rate Categories.....	4	
CCSAC Service Provisioning.....	6	
Common Channel Signaling Access Capability (CCSAC) .....	2	(T)
		(D)
General Description .....	1	(C)
		(D)
Ordering, Service Provisioning and Performance Requirements .....	5	
Rate Categories .....	4	
Rates and Charges.....	9	(D)
Service Description.....	1.1	(T)
Testing Requirements .....	7	

**Qwest Corporation**  
**Access Service**  
**Catalog No. 1**

**SECTION 15**

Page 1

Release 2

Effective: 8-9-08

**NORTHERN IDAHO**  
Issued: 7-30-08

**15. COMMON CHANNEL SIGNALING NETWORK (CCSN)**

**15.1 GENERAL DESCRIPTION**

Where available, Common Channel Signaling Access Capability (CCSAC) allows a customer to connect with the Company's SS7 network. CCSAC is used in conjunction with other SS7 based features and services. CCSAC provides the means for transmitting SS7 out of band signaling information via Switched Access CCS Links between the customer's Signaling Point of Interface (SPOI) and the Company's Signal Transfer Point (STP) or Facility Signaling Point of Interconnection (FSPOI). The STP provides translations and routing functions for SS7 signaling messages received from the Company's network signaling points and the SS7 networks of other entities. There are two types of signaling messages. ISDN User Part (ISUP) messages are used for call set-up (establishing and closing transmission paths for voice and data calls over the public switched network). Transaction Capabilities Application Part (TCAP) messages are used to carry information between signaling points for call related database services. CCSAC acts as a platform for the following applications.

(C)  
(D)  
(C)

The customer's SPOI and the Company's STP or FSPOI wire center must be located within the same LATA.

(C)

**A. Call Set-Up**

(N)

This application provides the customer the capability to send originating and terminating call set-up signaling information, via ISUP messages, between the customer's designated premises, the Company's STP and other entities in association with message telecommunications service. Call Set-Up may be associated with calls that utilize the Company's switched access network or may be associated with calls that do not utilize the Company's switched access network. If the message trunks are provided by the Company, the customer must order the associated FGD trunks with SS7 Out of Band Signaling option as set forth in Section 6, preceding. Call Set-Up associated with calls that do not utilize the Company's switched access network is referred to as transient call set-up and the customer must have message trunks with SS7 capabilities. CCSAC Service as set forth in this section is required to provide both capabilities.

**B. Foreign Database Queries**

This service provides the customer the ability to query foreign databases (databases not maintained by the Company) by sending signaling information via TCAP messages between the Company's STP, the customer's designated premises and the foreign database. CCSAC Service as set forth in this section is required to provide this capability.

(N)

(M) Material moved to Page 1.1.

**Qwest Corporation**  
Access Service  
Catalog No. 1

**SECTION 15**  
Page 1.1  
Release 1  
Effective: 8-9-08

**NORTHERN IDAHO**  
Issued: 7-30-08

**15. COMMON CHANNEL SIGNALING NETWORK (CCSN)**

**15.2 SERVICE DESCRIPTION**

**15.2.1 COMMON CHANNEL SIGNALING ACCESS CAPABILITY (CCSAC)**

(M)

CCSAC transmission specifications, diversity requirements and testing parameters are set forth in Technical Reference GR-905-CORE, GR-954-CORE and 77342. Diversity will be provided as mutually agreed upon by the Company and the customer based upon availability from the customer's STP, SP or SSP location to the Company's STP. If applicable, Special Construction terms, conditions and charges will apply. CCSAC interconnection is available only in suitably equipped Company STP locations.

(N)

CCSAC network interface specifications between the Company's STP location and the customer's STP location supporting Integrated Services Digital Network (ISDN) signaling are described in Technical Reference GR-905-CORE.

(N)

**A. CCS Link**

(M)

CCSAC is provided by a CCS Link. The CCS Link provides digital bidirectional transmission and operates at a DS0-A level (i.e., 56 kbps of CCS7 signaling data and 8 kbps of control/supervisory data). Each DS0-A channel (link) occupies a single DS0 (i.e., 64 kbps) channel of a 24 channel DS1 digital transmission system. The DS0-A channel (link) is multiplexed into a DS1 format for hand off at the customer's SPOI. One STP Port is required for each 56 kbps signaling link utilized for CCSAC at the Company STP. The customer's SPOI and the Company's STP, or FSPOI, wire center must be located within the same LATA. Customer connections at an FSPOI will only provide signaling access for the LATA served by the FSPOI. Customer connections for multiple LATAs, where available, must be made at the Company STP. The STP Port is the POT to the signal switching capability of the STP and is dedicated to the customer. The CCS Link is transported via an Entrance Facility and a Direct Link Transport (DLT) facility as described in 1. and 2., following, and is utilized exclusively for connecting the customer's CCS network and the Company's CCSN for the transmission of network control signaling data only.

(C)

(C)

(M)

(M) Material moved from Page 1.

NOTICE  
THE INFORMATION CONTAINED IN THIS DOCUMENT IS SUBJECT TO CHANGE.

**Qwest Corporation**  
Access Service  
Catalog No. 1

SECTION 15  
Page 2  
Release 2  
Effective: 8-9-08

NORTHERN IDAHO  
Issued: 7-30-08

**15. COMMON CHANNEL SIGNALING NETWORK (CCSN)**

**15.2 SERVICE DESCRIPTION**

**15.2.1 COMMON CHANNEL SIGNALING ACCESS CAPABILITY (CCSAC)**

A. CCS Link (Cont'd)

1. Entrance Facility

The Entrance Facility provides the connection from the customer's SPOI to the serving wire center (SWC) of the customer's SPOI on a dedicated DS1 facility ordered as set forth in this section and is utilized exclusively for the transmission of network control signaling data only. The customer may utilize an existing DS1 Entrance Facility previously ordered from this section for additional CCS Links or order a new DS1 Entrance Facility from this section. The customer may also choose to utilize a portion (i.e., DS1) of an existing DS3 facility under the regulations of Shared Use. The DS3 facility can only be ordered from Section 6, preceding or Section 7, of the Interstate Access Service Tariff, F.C.C. No. 1. Multiplexing arrangements and the associated regulations are set forth in 6.1.2, preceding. When the customer chooses to use a portion of an existing DS3 facility, the customer must allocate, at a minimum, one dedicated DS1 for the provision of the signaling links. Rate applications for Shared Use are set forth in 2.7, preceding.

(C)  
(C)

2. Direct Link Transport (DLT)

The DLT provides for the transmission facilities between the SWC of the customer's SPOI and the Company's STP or FSPOI. The customer has the option of ordering a DS1 DLT facility from this section, utilized exclusively for the transmission of network control signaling data only, or a single DS0-A channel (i.e., 64 kbps) of a 24 channel DS1 facility. The customer may utilize an existing DS1 DLT facility previously ordered from this section for additional CCS Links or order a new DS1 DLT or a DS0 DLT facility.

(C)

Company hubbing arrangements can be utilized for CCSAC. If the customer has an existing DS3 facility between the SWC of the customer's premises and a Company Hub, ordered and provisioned as set forth in Section 6, preceding, or Section 7 of the Interstate Access Service Tariff, F.C.C. No. 1, the customer may utilize a portion (i.e., DS1) of the existing DS3 facility for the CCS Link(s) under the provisions of the Shared Use regulations as set forth in 2.7, preceding. In addition, the customer must order the DS1 or DS0 DLT from the Company Hub to the Company STP or FSPOI.

(C)  
(C)

**Qwest Corporation**  
**Access Service**  
**Catalog No. 1**

**SECTION 15**  
Page 3  
Release 2  
Effective: 8-9-08

**NORTHERN IDAHO**  
Issued: 7-30-08

**15. COMMON CHANNEL SIGNALING NETWORK (CCSN)**

**15.2 SERVICE DESCRIPTION**

**15.2.1 COMMON CHANNEL SIGNALING ACCESS CAPABILITY (CCSAC)**

A.2. (Cont'd)

When the customer orders a DS1 DLT facility from the SWC of the customer's SPOI or a Company Hub to a Company STP or FSPOI, the customer must also order a DS1 to DS0 Multiplexer at the Company STP or FSPOI for termination into the STP Port. When the customer orders a DS0 DLT channel, the customer must also order a DS1 to DS0 Multiplexer at the SWC of the customer's SPOI. Multiplexing rates are set forth in 15.8, following.

(C)

(C)

(D)

(D)

**Qwest Corporation**  
Access Service  
Catalog No. 1

SECTION 15  
Page 4  
Release 2  
Effective: 8-9-08

NORTHERN IDAHO  
Issued: 7-30-08

**15. COMMON CHANNEL SIGNALING NETWORK (CCSN)**

**15.3 RATE CATEGORIES**

**15.3.1 CCSAC RATE CATEGORIES**

CCS Link rates and charges are set forth in 15.8, following. Carrier Common Line, as set forth in Section 3, preceding, and Switched Access rates, as set forth in Section 6, preceding, are not applicable.

A. Nonrecurring Charges (N)

Each CCS Link is assessed a nonrecurring charge per link provided on a first and each additional basis, per order. (C)

Any change in CCSAC Service, except a change in jurisdiction, will be treated as a discontinuance of the existing service and an installation of a new service. (C)  
(T)  
Minimum period requirements are set forth in 5.2.5, preceding. (C)

B. Monthly Rates (N)

The Entrance Facility monthly rate is assessed on a per DS1 facility provided when the Entrance Facility is ordered from this section for CCSAC. When the customer has Shared Use facilities, the monthly rates are apportioned as set forth in 2.7, preceding.

For each DLT facility provided, DS0 or DS1, a fixed monthly rate, per mile band, and a monthly rate per mile is assessed. When the customer has Shared Use facilities, the monthly rates are apportioned as set forth in 2.7, preceding. Mileage measurement is calculated on a airline mile basis, using the V & H coordinates method, between the SWC of the customer's SPOI and the Company's STP or FSPOI. When DLT facilities of different capacities are connected by a multiplexer at a Company Hub, mileage is measured separately from the SWC of the customer's premises to the Company Hub, where multiplexing occurs, and then measured from the Company Hub to the Company STP or FSPOI. (T)  
(C)  
(C)

An STP Port is provided for each CCS Link and each STP Port is assessed a monthly rate.

EF and DTT multiplexing equipment is assessed a monthly rate per arrangement provided. When the customer has Shared Use facilities, the monthly rates are apportioned as set forth in 2.7, preceding. (C)

**Qwest Corporation**  
Access Service  
Catalog No. 1

SECTION 15  
Page 4.1  
Release 1  
Effective: 8-9-08

NORTHERN IDAHO  
Issued: 7-30-08

**15. COMMON CHANNEL SIGNALING NETWORK (CCSN)**

**15.3 RATE CATEGORIES**

**15.3.1 CCSAC RATE CATEGORIES (Cont'd)**

C. Message Charges

Message charges, as set forth in 15.8, following, are assessed based on the type of message protocol, ISUP or TCAP. ISUP messages are associated with call set-up, while TCAP messages are used to query call related databases. ISUP message charges are assessed per call set-up request and TCAP message charges are assessed per data request.

Message charges do not apply for TCAP messages switched by the regional STPs to the Company provided 800 Data Base, LIDB or LNP Data Base. Query charges are assessed in lieu of message charges. Query charges for 800 Data Base are assessed as set forth in 6.8, preceding. When TCAP messages are destined for a foreign database, including a non-company provided LNP Data Base, message charges are assessed in lieu of query charges.

Message charges are assessed in the following manner.

1. Signal Formulation

An ISUP Signal Formulation charge is assessed, per call set-up request, for formulating signaling messages in association with call set-up.

2. Signal Transport

An ISUP Signal Transport charge is assessed, per call set-up request, for signaling messages transported to or from the Company STP in association with call set-up.

A TCAP Signal Transport charge is assessed per data request transported to or from a Company STP and destined for a foreign database.

3. Signal Switching

An ISUP Signal Switching charge is assessed per call set-up request that is switched at the Company STP.

A TCAP Signal Switching charge is assessed for each data request that is switched by the Company STP and destined for a foreign network or database.

(N)

(N)

**Qwest Corporation**  
Access Service  
Catalog No. 1

**SECTION 15**  
Page 5  
Release 2  
Effective: 8-9-08

**NORTHERN IDAHO**  
Issued: 7-30-08

**15. COMMON CHANNEL SIGNALING NETWORK (CCSN)**

**15.4 REPORT REQUIREMENTS**

**15.4.1 CCSAC NETWORK MANAGEMENT**

The customer shall provide semiannually a CCSAC Network Management Report. The CCSAC Network Management Report requirements are described in Qwest Corporation Technical Reference PUB 77342. The Company will use the report information in its own effort to further project CCSN facility requirements.

**15.5 ORDERING, SERVICE PROVISIONING AND PERFORMANCE REQUIREMENTS**

**15.5.1 CCSAC ORDERING REQUIREMENTS**

When a customer orders CCSAC, the customer must specify the customer STP premises, the number of CCS Links and the service (application) requiring CCSAC connectivity. One STP Port is provided for each link ordered. In addition, the customer must specify, at a minimum, information for the Entrance Facility and the DLT as described following.

(C)  
(C)

The customer must have capacity available on an existing DS1 Entrance Facility (ordered and provisioned from this section) or a DS3 facility (ordered and provisioned from Section 6, preceding or Section 7, of the Interstate Access Service Tariff, F.C.C. No. 1.) between the customer's SPOI and the SWC of the customer's SPOI with a compatible interface or request a DS1 Entrance Facility. If the Entrance Facility is existing, the customer shall provide the Circuit Facility Assignment (CFA) of the existing facilities that will be utilized.

In addition the customer must specify the type of DLT facility, DS1 or DS0, to be utilized or provided between the SWC of the customer's SPOI and the Company's STP or FSPOI.

(C)  
|  
(C)

The Company will allow Company provided hubbing arrangements in association with CCSAC.

If the customer has an existing DS3 facility (ordered and provisioned from Section 6, preceding, or Section 7, of the Interstate Access Service Tariff, F.C.C. No. 1.) to a Company Hub, the customer may use a portion of the DS3 facility (i.e., DS1) for the CCS Link(s) from the SWC of the customer's SPOI to the Company Hub and then order the DS1 or DS0 DLT from the Company Hub to the Company's STP or FSPOI. If the customer requests a DS1 DLT, multiplexing equipment must be ordered at the Company's STP or FSPOI. CCSAC orders are subject to the provisions (e.g., access order intervals, modification charges, cancellation charges and minimum periods) specified in Section 5, preceding.

(C)  
(C)

NOTICE  
THE INFORMATION CONTAINED IN THIS DOCUMENT IS SUBJECT TO CHANGE.

**Qwest Corporation**  
Access Service  
Catalog No. 1

**SECTION 15**  
Page 6  
Release 2  
Effective: 8-9-08

**NORTHERN IDAHO**  
Issued: 7-30-08

**15. COMMON CHANNEL SIGNALING NETWORK (CCSN)**

**15.5 ORDERING, SERVICE PROVISIONING AND PERFORMANCE REQUIREMENTS**

**15.5.1 CCSAC ORDERING REQUIREMENTS (Cont'd)**

When a customer orders CCSAC in association with other services (e.g., FGD with SS7 Out of Band Signaling for call set-up), separate orders shall be issued.

(N)  
|  
(N)

**15.5.2 CCSAC SERVICE PROVISIONING**

CCSAC transmission specifications, diversity requirements, testing parameters and design requirements for STP Links (i.e., CCS Signaling Links) are set forth in Technical References GR-905-CORE, GR-954-CORE and 77342. CCSAC network interface specifications between the Company STP location and the customer's STP location supporting Integrated Services Digital Network (ISDN) signaling are described in Technical Reference GR-905-CORE.

(C)  
  
(C)  
(C)

CCSAC is provided from either the customer's Signaling Point (SP) which requires a minimum of two STP Links and two STP Ports or from the customer's STP which requires a minimum of four STP Links and four STP Ports. A group of signaling links that connect the same two signaling points is described as a link set. There are a maximum of 16 signaling links located within one link set. The quantity of CCS Links required is based upon diversity requirements. Diversity is provided as mutually agreed upon by the Company and the customer based upon the availability of facilities from the customer's SPOI location to the Company's STP or FSPOI. Customer connections at an FSPOI will only provide two diverse routes to the Company STP. If applicable, Special Construction regulations and charges apply. CCSAC interconnection is available only in suitably equipped Company STP locations.

(T)  
  
(T)  
(C)  
|  
(C)  
  
(C)  
|  
(C)

**15.5.3 CCSAC PERFORMANCE REQUIREMENTS**

The Company supports the performance standards for CCSN as defined in Technical References GR-905-CORE and PUB 77342. The overall end-to-end CCSN network objective from any SP to any other SP is less than ten minutes unavailable access per year based on design and diversity requirements and the performance objective for any single SP, including a Service Control Point (SCP), is less than three minutes unavailable access per year. The combined link set from the SCP to the Signal Transfer Point (STP) has a performance objective of less than two minutes unavailable access per year.

(C)

**Qwest Corporation**  
Access Service  
Catalog No. 1

**SECTION 15**  
Page 7  
Release 2  
Effective: 8-9-08

**NORTHERN IDAHO**  
Issued: 7-30-08

**15. COMMON CHANNEL SIGNALING NETWORK (CCSN)**

**15.5 ORDERING, SERVICE PROVISIONING AND PERFORMANCE REQUIREMENTS)**

**15.5.3 CCSAC PERFORMANCE REQUIREMENTS (Cont'd)**

The Company will administer its CCSN network to ensure acceptable service provision levels. The Company maintains the right to apply protective controls to its CCSN as a result of occurrences such as failure or overload of CCSN facilities, natural disasters, mass calling or national security demands. In the event that the protective controls applied by the Company result in the complete loss of CCSAC Service by the customer, the customer will be entitled to a credit allowance for Switched Access Service interruptions as set forth in 2.4.5, preceding.

When the customer or the Company, pursuant to an order for service, arranges to establish a route to a signaling point, such route will be used by all messages delivered to the Company's signaling network.

(N)  
|  
(N)

**15.6 TESTING REQUIREMENTS**

**15.6.1 CCSAC ACCEPTANCE TESTING REQUIREMENTS**

At no additional charge, the Company will cooperatively test with the customer, at the time of installation, network compatibility and other operational tests for CCSAC as described in Technical References 77342 and GR-905-CORE.

(C)  
(C)

When Clear Channel Capability on FGD Service is ordered as described in 6.3.1, preceding, the Company will cooperatively test with the customer, at the time of installation, CCSAC network compatibility and other operational tests for ISDN interworking as described in Technical Reference GR-905-CORE, at no additional charge.

(C)

Successful completion and acceptance of all testing requirements must occur in order to receive CCSAC Service.

**15.6.2 CCSAC ADDITIONAL COOPERATIVE ACCEPTANCE TESTING REQUIREMENTS**

Additional Cooperative Acceptance Testing will be performed on a cooperative basis with the customer. Additional Cooperative Acceptance tests for CCSAC are described in Technical References 77342 and GR-905-CORE.

(C)

Rates and charges for Additional Cooperative Acceptance Testing are described in 12, preceding.

(T)

**Qwest Corporation**  
Access Service  
Catalog No. 1

**SECTION 15**  
Page 8  
Release 2  
Effective: 8-9-08

**NORTHERN IDAHO**  
Issued: 7-30-08

**15. COMMON CHANNEL SIGNALING NETWORK (CCSN)**

**15.7 CCSAC SERVICE APPLICATIONS**

**15.7.1 CALL SET-UP**

This application provides the customer the capability to send originating and terminating call set-up signaling information, via ISUP messages, between the customer's designated premises, the Company's STP and other entities in association with message telecommunications service.

Call Set-Up may be associated with calls that utilize the Company's switched access network or may be associated with calls that do not utilize the Company's switched access network. If the message trunks are provided by the Company, the customer must order the associated FGD trunks with SS7 Out of Band Signaling option as set forth in Section 6, preceding. Call Set-Up associated with calls that do not utilize the Company's Switched Access network is referred to as transient call set-up and the customer must have message trunks with SS7 capabilities. CCSAC Service as set forth in this section is required to provide both capabilities.

**15.7.2 FOREIGN DATABASE QUERIES**

This service provides the customer the ability to query foreign databases (databases not maintained by the Company) by sending signaling information via TCAP messages between the Company's STP, the customer's designated premises and foreign databases (those not owned by the Company). CCSAC Service as set forth in this section is required to provide this capability.

(C)

(C)

(D)

(N)

(N)

(C)

(D)

(N)

(N)

**Qwest Corporation**  
**Access Service**  
**Catalog No. 1**

**SECTION 15**  
Page 9  
Release 1  
Effective: 8-1-05

**NORTHERN IDAHO**  
Issued: 7-1-05

**15. COMMON CHANNEL SIGNALING NETWORK (CCSN)**

**15.8 RATES AND CHARGES**

A. Common Channel Signaling Access Capability

	<b>USOC</b>	<b>MONTHLY RATE</b>
1. Entrance Facility		
• Per DS1	EFY1X,FE4EX	\$ 125.00
• Per DS3[1]	EFY3X,FE4FX	1,350.00
2. Direct Link Transport		

	<b>USOC</b>	<b>MONTHLY RATE</b>	
		<b>FIXED</b>	<b>PER MILE</b>
<b>MILEAGE BANDS</b>			
a. DS0 Facility			
0	CCA2A,FFA21	-	-
Over 0 to 8	CCA2B,FFA22	\$ 26.00	\$ 0.17
Over 8 to 25	CCA2C,FFA23	26.00	0.17
Over 25 to 50	CCA2D,FFA24	26.00	0.17
Over 50	CCA2E,FFA25	26.00	0.22
b. DS1 Facility			
0	CCA1A,FFA11	-	-
Over 0 to 8	CCA1B,FFA12	86.50	13.55
Over 8 to 25	CCA1C,FFA13	111.21	14.38
Over 25 to 50	CCA1D,FFA14	116.35	14.51
Over 50	CCA1E,FFA15	130.00	15.05
c. DS3 Facility[1]			
0	CCA3A,FFA31	-	-
Over 0 to 8	CCA3B,FFA32	724.84	78.90
Over 8 to 25	CCA3C,FFA33	724.84	78.90
Over 25 to 50	CCA3D,FFA34	724.84	80.73
Over 50	CCA3E,FFA35	815.44	91.74

[1] For Shared Use only as set forth in 2.7, preceding.

**NOTICE**  
**THE INFORMATION CONTAINED IN THIS DOCUMENT IS SUBJECT TO CHANGE.**

**Qwest Corporation**  
Access Service  
Catalog No. 1

SECTION 15  
Page 10  
Release 2  
Effective: 8-9-08

NORTHERN IDAHO  
Issued: 7-30-08

**15. COMMON CHANNEL SIGNALING NETWORK (CCSN)**

**15.8 RATES AND CHARGES**

A. Common Channel Signaling Access Capability (Cont'd)

	USOC	NONRECURRING CHARGE	MONTHLY RATE
3. CCS Link			
• First CCS Link	NRBS1,NRME6	\$567.00	-
• Each additional	NRBSA,NRME7	180.00	-
4. STP PORT, per port	PT8SX	-	\$425.00
5. Multiplexing			
• DS1 to Voice	QMVXX,FMCNX	-	218.40
• DS3 to DS1[1]	QM3XX,FMC5X	-	255.00

B. Message Charge

	INTRASTATE RATE	OTHER RATE	
1. Signal Formulation			
• ISUP, Per call set-up request	\$0.000829	-	
2. Signal Transport			
• ISUP, Per call set-up request	0.000559	-	
• TCAP, Per data request	0.000418	-	
3. Signal Switching			
• Per ISUP, Per call set-up request	0.001162	-	
• Per TCAP, Per data request	0.000460	-	

(N)

(N)

[1] For Shared Use only as set forth in 2.7, preceding.

**Qwest Corporation**  
**Access Service**  
**Catalog No. 1**

**SECTION 21**  
Index Page 1  
Release 1

**NORTHERN IDAHO**  
Issued: 7-1-05

Effective: 8-1-05

---

**21. EXPANDED INTERCONNECTION (EI) SERVICE**

<b>SUBJECT</b>	<b>PAGE</b>
Expanded Interconnection Channel Termination .....	3
General .....	1
Rate Terms and Conditions .....	4
Rates and Charges .....	5
Service Descriptions .....	3
Switched Access Service Virtual EI .....	5
Types of Rates and Charges .....	4

NOTICE  
THE INFORMATION CONTAINED IN THIS DOCUMENT IS SUBJECT TO CHANGE.

**Qwest Corporation**  
**Access Service**  
**Catalog No. 1**

**SECTION 21**  
Page 1  
Release 1  
Effective: 8-1-05

**NORTHERN IDAHO**  
Issued: 7-1-05

---

**21. EXPANDED INTERCONNECTION (EI) SERVICE**

**21.1 GENERAL**

Expanded Interconnection (EI) Service provides for wire center interconnection of Company-provided Switched Access DS1 or DS3 capacity services to interconnector-provided or designated transmission equipment as described in the Company's Interstate Access Service Tariff F.C.C. No. 1.

EI may be accomplished through a virtual interconnection arrangement. The Company is solely responsible for the determination of whether a virtual interconnection arrangement is available from its wire center. Each wire center where Virtual EI Service is available is identified in the National Exchange Carrier Association Inc., Tariff F.C.C. No. 4.

Technical information for EI Service may be found in Qwest Corporation Technical Reference PUB 77201. Technical information for DS1 Service and DS3 Service may be found in Qwest Corporation Technical Reference PUB 77375 and 77324, respectively.

**NOTICE**  
**THE INFORMATION CONTAINED IN THIS DOCUMENT IS SUBJECT TO CHANGE.**

**Qwest Corporation**  
**Access Service**  
**Catalog No. 1**

**SECTION 21**  
Page 2  
Release 1  
Effective: 8-1-05

**NORTHERN IDAHO**  
Issued: 7-1-05

---

**21. EXPANDED INTERCONNECTION (EI) SERVICE**

**21.1 GENERAL (Cont'd)**

EI Service will be provided utilizing a Switched Access Service Expanded Interconnection Channel Termination (EICT) DS1 or EICT DS3. EICT DS1 or EICT DS3 may be ordered for connection with Switched Access DS1 or DS3 capacity services as set forth in Section 6, preceding. Multiplexing arrangements for Switched Access EICT may be ordered from Section 6, preceding, by the EICT customer. The Company will provide interconnection at a 1.544 Mbps or a 44.736 Mbps transmission rate.

When an EICT DS1 or EICT DS3 connects to Switched Access Service, the Switched Transport Entrance Facility is not required. In addition, when a multiplexing arrangement is requested as described in 6.1.2, preceding, the multiplexing arrangement must be ordered by and billed to the EICT customer.

The regulations described herein are in addition to the terms and conditions elsewhere in this document.

Virtual EICT DS1 or EICT DS3 can only be ordered by and billed to the customer of record of the fiber optic cable at the Company-designated point of interconnection serving the wire center.

The Company will work cooperatively with the interconnector in matters of joint testing and maintenance as set forth in Section 12, preceding.

**NOTICE**  
**THE INFORMATION CONTAINED IN THIS DOCUMENT IS SUBJECT TO CHANGE.**

**Qwest Corporation**  
**Access Service**  
**Catalog No. 1**

**SECTION 21**  
Page 3  
Release 1  
Effective: 8-1-05

**NORTHERN IDAHO**  
Issued: 7-1-05

---

**21. EXPANDED INTERCONNECTION (EI) SERVICE**

**21.2 SERVICE DESCRIPTIONS**

**21.2.1 EXPANDED INTERCONNECTION CHANNEL TERMINATION**

A. Virtual EICT DS1

A Virtual EICT DS1 is a high capacity channel for the transmission of 1.544 Mbps isochronous serial data having a line code of bipolar with alternate mark inversion or Bipolar with Eight Zero Substitution (B8ZS). The 1.544 Mbps signal consists of 1.536 Mbps of customer information and .008 Mbps signal for other use, (e.g., framing and synchronization).

Switched Access Service Virtual EICT DS1 is provided between Company-owned, interconnector-designated terminating equipment and a Company Switched Access DS1 capacity service ordered from Section 6, preceding. Multiplexing arrangements for Switched Access EICT may be ordered from Section 6, preceding, by the EICT customer.

B. Virtual EICT DS3

A Virtual EICT DS3 is a high capacity channel for the transmission of 44.736 Mbps isochronous serial data having a line code of Bipolar with Three Zero Substitution (B3ZS).

Switched Access Service Physical EICT DS3 is provided between an interconnector's leased physical space and a Company Switched Access DS3 capacity service ordered from Section 6, preceding. Multiplexing arrangements for Switched Access EICT may be ordered from Section 6, preceding, by the EICT customer.

**NOTICE**  
**THE INFORMATION CONTAINED IN THIS DOCUMENT IS SUBJECT TO CHANGE.**

**Qwest Corporation**  
**Access Service**  
**Catalog No. 1**

**SECTION 21**  
Page 4  
Release 1  
Effective: 8-1-05

**NORTHERN IDAHO**  
Issued: 7-1-05

---

**21. EXPANDED INTERCONNECTION (EI) SERVICE**

**21.3 RATE TERMS AND CONDITIONS**

This section contains specific regulations governing the rates and charges that apply for EI Service. Company services purchased by the interconnector for interconnection with EI Service are subject to appropriate nonrecurring charges, monthly rates and other applicable rates and charges as set forth in Section 6, preceding.

**21.3.1 TYPES OF RATES AND CHARGES**

There are two types of rates and charges. These are monthly rates and nonrecurring charges. The rates and charges are described as follows:

**A. Monthly Rates**

Monthly rates are recurring rates that apply each month or fraction thereof that an EI Service is provided. For billing purposes, each month is considered to have thirty (30) days.

The Virtual EI Channel Termination (EICT) rate element provides for the communications path between the interconnector-designated equipment and Company Switched Transport DS1 or DS3 capacity service within the same wire center. Included as part of the EICT is a standard channel interface arrangement which defines the technical characteristics associated with the type of facilities to which the Switched Access Service is to be connected and the type of signaling capability, if any.

**B. Nonrecurring Charges**

Nonrecurring charges are one-time charges that apply for a specific work activity (i.e., installation or change to an existing service). The types of nonrecurring charges that apply for EI Service include: installation of EICT DS1 or DS3 Channel Terminations.

Nonrecurring charges applicable to each EICT DS1 or EICT DS3 channel termination installed are set forth in 21.4, following.

**NOTICE**  
**THE INFORMATION CONTAINED IN THIS DOCUMENT IS SUBJECT TO CHANGE.**

**Qwest Corporation**  
**Access Service**  
**Catalog No. 1**

**SECTION 21**  
Page 5  
Release 1  
Effective: 8-1-05

**NORTHERN IDAHO**  
Issued: 7-1-05

---

**21. EXPANDED INTERCONNECTION (EI) SERVICE**

**21.4 RATES AND CHARGES**

**21.4.1 SWITCHED ACCESS SERVICE VIRTUAL EI**

	<b>USOC</b>	<b>NONRECURRING CHARGE</b>	<b>MONTHLY RATE</b>
Virtual EI Channel Termination, per termination			
• DS1 Switched Transport	TYLFA	\$366.88	\$14.93
• DS3 Switched Transport	TYLGA	392.02	42.97

**NOTICE**  
**THE INFORMATION CONTAINED IN THIS DOCUMENT IS SUBJECT TO CHANGE.**