

**Qwest Corporation**  
**Exchange and Network**  
**Services Catalog No. 1**

**SECTION 107**  
Index Page 1  
Release 1  
Effective: 12-9-2006

**SOUTHERN IDAHO**  
Issued: 12-8-2006

**107. OBSOLETE WIDE AREA TELECOMMUNICATIONS SERVICE**

(N)

<b>SECTION</b>	<b>PAGE</b>
800 Serviceline Option .....	1
Volume Discounts .....	12
Abuse or Fraudulent Use .....	7
Allowance for Interruptions .....	10
Ancillary WATS Service .....	13
Application of Monthly Rates and Usage .....	8
Chargeable Time .....	8
Company Liability .....	5
Completion of 800 Serviceline Option Messages.....	6
Connection to Other Services .....	4
Description .....	1
Directory Listings .....	9
Fractional Periods .....	9
Limitations of Service .....	4
Minimum Service Period .....	9
Payment of Charges .....	9
Payphone Surcharge.....	11
Priority of Services .....	4
Rates and Charges.....	12
Transmission Quality .....	6
Use of Service .....	7
WATS Terminations .....	3

(N)

NOTICE  
THE INFORMATION CONTAINED IN THIS DOCUMENT IS SUBJECT TO CHANGE.

**Qwest Corporation**  
**Exchange and Network**  
**Services Catalog No. 1**

**SECTION 107**

Page 1

Release 1

**SOUTHERN IDAHO**  
Issued: 12-8-2006

Effective: 12-9-2006

**107. OBSOLETE WIDE AREA TELECOMMUNICATIONS SERVICE**

(N)

Terms and conditions found in Section 6, paragraphs 6.1.A. through 6.1.P. are made a part of this Section 107 by reference.

**107.1 800 SERVICELINE OPTION**

A. Description

- 1. Wide Area Telecommunications Service (WATS) provides for dial-type communications between a WATS termination and exchanges within the same LATA, within the State and in accordance with the regulations and schedules of charges specified in this document.
- 2. A WATS access line is a line from the Company CO to the Company-provided network interface on or near the customer's premises and is provided for the purpose of completing WATS calls.

3. WATS is provided as 800 Serviceline Option:

(N)

- a. The 800 Serviceline option customer is furnished an 8XX number (i.e., 800, 822, 833, 844, 855, 866, 877 or 888, as available) to be associated with an individual line or trunk. 800 Serviceline option is an option served over an exchange access facility and is not an access line. One 8XX number may be assigned to each existing or newly provided exchange telephone number which allows for the completion of 8XX calls in addition to all other usage normally handled on this termination. Message detail (calling number/calling location, where possible, and duration of calls) is included. Billing is based on a specified rate per hour as set forth in 107.1.3, following. Volume discounts may apply.

(T)(M)

(M)

(M) Material moved from Section 7.

NOTICE  
THE INFORMATION CONTAINED IN THIS DOCUMENT IS SUBJECT TO CHANGE.

**Qwest Corporation**  
**Exchange and Network**  
**Services Catalog No. 1**

**SECTION 107**

Page 2

Release 1

**SOUTHERN IDAHO**  
Issued: 12-8-2006

Effective: 12-9-2006

**107. OBSOLETE WIDE AREA TELECOMMUNICATIONS SERVICE**

(N)

**107.1 800 SERVICELINE OPTION**

A. Description (Cont'd)

4. WATS is furnished only if the necessary service components are available. If unusual costs are involved to make facilities available, the customer may have to pay additional charges. (N)
5. Intrastate 800 Serviceline option may be provided jointly by the Company and the Interexchange Carrier on a complementary basis. A complementary service is where the Company provides the 8XX number to be associated with an individual line or trunk, transports the intraLATA traffic and bills both the 8XX number and intraLATA usage to the end user as set forth in this Catalog. The interLATA traffic is transported and billed by the Interexchange Carrier as set forth in 5., preceding. (T)(M)
6. A dual jurisdiction WATS access line is a facility used for the provision of interstate and intrastate WATS and is provided subject to the terms and conditions of the Company's Interstate Access Service Tariff F.C.C. No. 1. Any intrastate intraLATA traffic retained and transported by the Company will be billed to the end user at the usage rates set forth in this Catalog. The interLATA traffic is transported and billed by the Interexchange Carrier as set forth in 5., preceding. (T)
7. IntraLATA only 800 Serviceline option will be provided by the Company. (T)(M)
8. Wire Center - a specified geographical location in an exchange from which charges for WATS extensions are determined. (N)
9. Service Terminating Arrangement - Company-provided equipment which terminates WATS access lines and facilitates design, isolation, and testing of WATS service. Protective connecting arrangements include the service terminating arrangement. (N)

(M) Material moved from Section 7.

NOTICE  
THE INFORMATION CONTAINED IN THIS DOCUMENT IS SUBJECT TO CHANGE.

**Qwest Corporation**  
**Exchange and Network**  
**Services Catalog No. 1**

**SECTION 107**

Page 3

Release 1

**SOUTHERN IDAHO**

Issued: 12-8-2006

Effective: 12-9-2006

**107. OBSOLETE WIDE AREA TELECOMMUNICATIONS SERVICE**

(N)

**107.1 800 SERVICELINE OPTION (Cont'd)**

**B. WATS Terminations**

1. The term "Station" as used in connection with WATS:
  - a. Denotes the network control signaling unit and any other equipment which is arranged for WATS and provided at a customer's premises in accordance with this Catalog or,
  - b. Denotes the point, at a customer's premises, at which customer-provided terminal equipment or communications system is connected to Company facilities furnished for WATS or,
  - c. Denotes the point of connection of WATS to switching equipment (as specified in 3., following) when such switching equipment is located in a Company CO or,
2. The term "Main Station" denotes the first WATS station furnished for use with a WATS access line. The term "Extension Station" denotes any other WATS station furnished for use with the same WATS access line.
3. At the option of the customer, a WATS access line may be connected to: (i) a standard telephone, (ii) an attendant's position or switching equipment of: a PBX or CO dial switched system, a Common Control Switching arrangement, (iii) a key telephone system, or (iv) an Interexchange Carrier Channel utilizing a WATS CO Connecting Facility.
4. When connections are made to customer or Interexchange Carrier-provided communications systems at a premises where the customer does not originate or terminate communications, the Company may require that WATS be furnished from a Company WATS CO(s) different than the CO(s) designated by the Company to serve that premises. Under such circumstances, monthly and service and equipment charges equal to access line extension charges apply between the WATS CO that would serve the customer's premises and the WATS CO from which service is actually provided.

(N)

**Qwest Corporation**  
**Exchange and Network**  
**Services Catalog No. 1**

**SECTION 107**

Page 4

Release 1

**SOUTHERN IDAHO**  
Issued: 12-8-2006

Effective: 12-9-2006

**107. OBSOLETE WIDE AREA TELECOMMUNICATIONS SERVICE**

(N)

**107.1 800 SERVICELINE OPTION (Cont'd)**

C. Limitations of Service

1. WATS calls must be dialed and completed without the assistance of a Company operator except when facilities or conditions do not allow customer dial completion or when an interrupted call is reestablished by a Company operator.
2. The design, maintenance and operation of WATS envisions that communications will originate or terminate at a WATS station for the purpose of communicating with stations in the specified service areas. Connections of communications system provided by the customer or Interexchange Carrier to WATS may be made. However, the Company will not be responsible for the through transmission of signals or for the quality of transmission on such connections.

3. Connection to Other Services

Connections of WATS to other services is permitted on a switched basis only. No permanent connection between WATS and other services may be established.

4. Priority of Services

- a. The installation and restoration of service shall be in accordance with the rules for Telecommunications Service Priority (TSP) as set forth in Section 12. of the Access Service Catalog.
- b. Subject to compliance with the above mentioned rules, when a shortage of facilities exists either for temporary or protracted periods, MTS will be established before all other services. However, the duration of MTS calls may be limited when facility shortages are caused by emergency conditions.

5. Outward WATS and 800 Serviceline are not eligible for Suspension of Service – Customer Initiated.

(N)

**Qwest Corporation**  
**Exchange and Network**  
**Services Catalog No. 1**

**SECTION 107**

Page 5

Release 1

**SOUTHERN IDAHO**  
Issued: 12-8-2006

Effective: 12-9-2006

**107. OBSOLETE WIDE AREA TELECOMMUNICATIONS SERVICE**

(N)

**107.1 800 SERVICELINE OPTION**

C. Limitations of Service (Cont'd)

5. Company Liability

- a. In view of the fact that the customer has exclusive control of communications over the facilities furnished by the Company, and of the other uses for which facilities may be furnished by the Company, and because of unavailability of errors incident to the services and to the use of such facilities of the Company, the services and facilities furnished by the Company are subject to the terms, conditions and limitations herein specified.
- b. The liability of the Company for damages arising out of mistakes, omissions, interruptions, delays, errors or defects in transmission, or failure or defects in facilities furnished by the Company, occurring in the course of furnishing service or other facilities and not caused by the negligence of the customer, or of the Company in failing to maintain proper standards of maintenance and operation and to exercise reasonable supervision shall in no event exceed an amount equivalent to the proportionate charge to the customer for the period of service during which such mistake, omission, interruption, delay, error, defect in transmission, or failure or defect in facilities occurs.
- c. The customer indemnifies and saves the Company harmless against claims for libel, slander, or infringement of copyright from the material transmitted over its facilities; against claims for infringement of patents arising from combining with, or using in connection with, facilities of the Company, apparatus and systems of the customer; and against all other claims arising out of any act or omission of the customer in connection with facilities provided by the Company.
- d. When the lines of other telephone companies are used in establishing connections to points not reached by the Company's lines, the Company is not liable for any act or omission of the other company or companies.
- e. The Company shall not be liable for any defacement of, or damage to, customer's premises resulting from the existence of the Company's instruments, apparatus, or wiring, on such premises, or caused by the installation or removal, when such defacement or damage is not the result of the negligence of the Company.

(N)

**Qwest Corporation**  
**Exchange and Network**  
**Services Catalog No. 1**

**SECTION 107**

Page 6

Release 1

**SOUTHERN IDAHO**  
Issued: 12-8-2006

Effective: 12-9-2006

**107. OBSOLETE WIDE AREA TELECOMMUNICATIONS SERVICE**

(N)

**107.1 800 SERVICELINE OPTION**

C.5. (Cont'd)

f. The Company does not guarantee nor make any warranty with respect to equipment provided by it for use in an explosive atmosphere. The customer shall indemnify and hold the Company harmless from any and all loss, claims, demands, suits, or other action, or any liability whatsoever, whether suffered, made, instituted or asserted by customer or by any other party or person, for any personal injury to or death of any person or persons, and for any loss, damage or destruction of any property, whether owned by the customer or others, caused or claimed to have been caused directly or indirectly by the installation, operation, failure to operate, maintenance, removal, presence, condition, location or use of said equipment so provided.

- (1) The Company may require each customer to sign an agreement for the furnishing of such equipment as a condition precedent to the furnishing of such equipment.
- (2) The customer shall furnish, install and maintain sealed conduit with explosion-proof fittings between this equipment and points outside the hazardous area where connection may be made with regular facilities of the Company. The customer may be required to install and maintain this equipment within the hazardous area if, in the opinion of the Company, injury or damage to Company employees or property might result from installation or maintenance by the Company.

6. Transmission Quality

Satisfactory transmission cannot be assured when the WATS access line is connected to other Company services or to customer-provided equipment or service.

7. Completion of 800 Serviceline Option Messages

800 Serviceline option is furnished upon condition that the customer obtain adequate facilities to permit the use of this service without interfering with this service or impairing it or without injurious effects upon it or any other service rendered by the Company. The Company, without incurring any liability, may terminate or refuse to furnish 800 Serviceline option to any customer who fails to comply with said conditions, provided that, in case of a termination of service, at least five days have elapsed following written notification to the customer by mail or in person of the Company's intention to terminate the service for such cause.

(N)

**Qwest Corporation**  
**Exchange and Network**  
**Services Catalog No. 1**

**SECTION 107**

Page 7

Release 1

**SOUTHERN IDAHO**  
Issued: 12-8-2006

Effective: 12-9-2006

**107. OBSOLETE WIDE AREA TELECOMMUNICATIONS SERVICE**

(N)

**107.1 800 SERVICELINE OPTION**

C. Limitations of Service (Cont'd)

8. Use of Service

WATS may be used by the customer or others authorized by the customer. Orders involving installation, rearrangement, billing, or discontinuance of service will be accepted by the Company only from the customer.

9. Abuse or Fraudulent Use

The service is furnished subject to the condition that there will be no abuse or fraudulent use of the service. Abuse or fraudulent use of service includes:

- a. The placing or acceptance of a WATS call by a WATS customer, a customer's agent, employee or representative, in response to an uncompleted MTS call, which was not completed in order to transmit or receive intelligence without the payment of the applicable message toll charge;
- b. The obtaining, or attempting to obtain, or assisting another to obtain or to attempt to obtain, WATS by rearranging, tampering with, or making connection with any facilities of the Company, or by any trick, scheme, false representation, or false credit device, or by or through any other fraudulent means or device whatsoever, with intent to avoid the payment, in whole or in part, of the regular charge for such service;
- c. The use of service or facilities of the Company for a call or calls, anonymous or otherwise if in a manner reasonably to be expected to frighten, abuse, torment, or harass another;
- d. The use of profane or obscene language;
- e. The use of the service in such a manner as to interfere unreasonably with the use of the service by one or more other customers.

(N)

**Qwest Corporation**  
**Exchange and Network**  
**Services Catalog No. 1**

**SECTION 107**

Page 8

Release 1

**SOUTHERN IDAHO**

Issued: 12-8-2006

Effective: 12-9-2006

**107. OBSOLETE WIDE AREA TELECOMMUNICATIONS SERVICE**

(N)

**107.1 800 SERVICELINE OPTION (Cont'd)**

D. Application of Monthly Rates and Usage

1. General

WATS usage charges are for payment for the service between the WATS termination and another location.

2. Chargeable Time

- a. Chargeable time begins when connection is established between a station associated with the WATS termination and the calling or called station.
- b. Chargeable time ends when the calling station "hangs up" thereby releasing the network connection. If the called station "hangs up" but the calling station does not, chargeable time ends when the network connection is released by automatic timing equipment in the telecommunications network.
- c. When 800 Serviceline option is directly connected (i.e., not connected through a multiline terminating system) at a customer's premises to a communications system, chargeable time begins when the call terminates in or passes through the first multiline terminating system or terminal equipment on that communications system. It is the customer's responsibility to furnish appropriate answer supervision to the point of connection with the 800 Serviceline option so that the chargeable time may begin.
- d. All calls completed in one billing period through 800 Serviceline option will be billed a minimum of 30 seconds per call.

(N)

(M)

(M)

(M) Material moved from Section 7.

NOTICE  
THE INFORMATION CONTAINED IN THIS DOCUMENT IS SUBJECT TO CHANGE.

**Qwest Corporation**  
**Exchange and Network**  
**Services Catalog No. 1**

**SECTION 107**  
Page 9  
Release 1  
Effective: 12-9-2006

**SOUTHERN IDAHO**  
Issued: 12-8-2006

**107. OBSOLETE WIDE AREA TELECOMMUNICATIONS SERVICE**

(N)

**107.1 800 SERVICELINE OPTION**

D. Application of Monthly Rates and Usage (Cont'd)

4. Minimum Service Period

The minimum service period for WATS is one day.

5. Payment of Charges

- a. The customer is responsible for payment of all charges for service furnished the customer. Service and equipment charges are payable upon establishment of service. All other charges from time to time in force and effect are payable monthly in advance, except additional hourly usage charges, which are payable upon rendition of a bill by the Company.
- b. Where a WATS application for service is canceled by the applicant prior to the start of installation of facilities, no charge applies. Where installation of facilities has been started prior to the cancellation, the service and equipment charges apply.
- c. Charges of less than a cent will be rounded to the nearest cent.

6. Fractional Periods

- a. The charge for a fractional part of a month will be a proportionate part of the monthly rate based on the actual number of days the service is provided.
- b. For the purpose of administering this regulation with respect to the determination of the charge for a fractional part of a month, every month is considered to have 30 days.

(N)

7. Directory Listings

(M)

- a. One free Directory listing will be provided for 800 Serviceline Option. Additional Directory listings will be provided at applicable additional listing rates. (See 5.7.1.)

(T)

(T)(M)

(M) Material moved from Section 7.

**Qwest Corporation**  
**Exchange and Network**  
**Services Catalog No. 1**

**SECTION 107**

Page 10

Release 1

**SOUTHERN IDAHO**  
Issued: 12-8-2006

Effective: 12-9-2006

**107. OBSOLETE WIDE AREA TELECOMMUNICATIONS SERVICE**

(N)

**107.1 800 SERVICELINE OPTION (Cont'd)**

E. Allowance for Interruptions

Allowance for interruptions apply to each WATS access line as set forth following:

1. When the WATS access line is interrupted for a period of less than 2 hours after the trouble is reported to the Company, no credit applies.
2. When the WATS access line is interrupted for a period of 2 hours to 24 hours after the trouble is reported to the Company, the following credit applies:

**CREDIT  
ALLOWANCE**

- Allowance

\$6.20

3. When the WATS access line is interrupted for a period of more than 24 hours after the trouble is reported to the Company, a credit applies for each 24 hour period or any fraction thereof.

**CREDIT  
ALLOWANCE**

- Allowance

\$6.20

(N)

**Qwest Corporation**  
**Exchange and Network**  
**Services Catalog No. 1**

**SECTION 107**

Page 11

Release 1

**SOUTHERN IDAHO**

Issued: 12-8-2006

Effective: 12-9-2006

**107. OBSOLETE WIDE AREA TELECOMMUNICATIONS SERVICE**

(N)

**107.1 800 SERVICELINE OPTION**

**E. Allowance For Interruptions (Cont'd)**

4. The credit in 2. and 3., preceding, includes all credits to be applied for an interruption.
5. None of the prior credit allowances will be made for:
  - Non-completion of WATS messages due to busy network conditions, or
  - Interruption of service due to customer-provided equipment or systems, or
  - Interruption of service due to negligence of the customer, or
  - Interruption of service during any period in which the Company is not afforded access to the premises at which the WATS access line is terminated, or
  - Interruption of service during any period when the customer has released the WATS access line to the Company for maintenance purposes, or implementation of a customer order for a change in service arrangement.
6. Message telecommunications service furnished at a customer's request, when his WATS is interrupted, is charged at the message telecommunications rates.
7. When 800 Serviceline option is interrupted, the credit allowance is the same as for the service with which it is associated.

(N)

(M)

(M)

**F. Payphone Surcharge**

(N)

The Payphone Surcharge applies to all calls placed from pay telephones. This charge is in addition to all other applicable 800 Serviceline rates and charges.

(N)

(M) Material moved from Section 7.

NOTICE  
THE INFORMATION CONTAINED IN THIS DOCUMENT IS SUBJECT TO CHANGE.

**Qwest Corporation**  
Exchange and Network  
Services Catalog No. 1

**SECTION 107**  
Page 12  
Release 1  
Effective: 12-9-2006

**SOUTHERN IDAHO**  
Issued: 12-8-2006

**107. OBSOLETE WIDE AREA TELECOMMUNICATIONS SERVICE**

(N)

**107.1 800 SERVICELINE OPTION (Cont'd)**

(N)

**107.1.3 800 SERVICELINE OPTION**

(M)

A. Rates and Charges

1. 800 Serviceline Option Number

	<b>USOC</b>	<b>MONTHLY RATE</b>
• Each	WFA++	\$5.00
		<b>NONRECURRING CHARGE</b>
• Changes		\$15.00

2. Fractional hours will be rounded to the nearest tenth of an hour.

	<b>RATE</b>
• Hourly rate	\$6.00

3. Volume Discounts

All usage in excess of \$60.00 will be discounted by the following percentages.

<b>AMOUNT</b>	<b>DISCOUNT</b>
0 thru \$60.00	0%
\$60.01 thru \$200.00	10%
\$200.01 thru \$500.00	12%
\$500.01 thru \$1,000.00	15%
Over \$1,000.00	20%

4. Payphone Surcharge

	<b>CHARGE</b>
• Per completed call[1]	\$0.55

[1] This charge is in addition to all other applicable 800 Serviceline rates and charges.

(M)

(M) Material moved from Section 7.

**Qwest Corporation**  
**Exchange and Network**  
**Services Catalog No. 1**

**SECTION 107**

Page 13

Release 1

**SOUTHERN IDAHO**  
Issued: 12-8-2006

Effective: 12-9-2006

**107. OBSOLETE WIDE AREA TELECOMMUNICATIONS SERVICE**

(N)

**107.1 800 SERVICELINE OPTION (Cont'd)**

(N)

**107.1.4 ANCILLARY WATS SERVICE**

(M)

A. Monthly Rates for Access Line Extensions

1. Access line extensions are provided only within the same LATA in this State.
2. The minimum service period for an access line extension is one day.
3. When a WATS access line has more than one termination, one is designated as the access line main station. All other terminations of the same access line are designated as access line extensions.

**USOC**

- Access Line Extensions[1]
  - First extension
  - Each additional extension

NX3  
EWW

(M)

[1] Rates and charges for Exchange Service Extension Service, as specified in the Access Service Catalog, apply.

(M)  
(M)

(M) Material moved from Section 7.

**Qwest Corporation**  
**Exchange and Network**  
**Services Catalog No. 1**

**SECTION 109**  
Index Page 1  
Release 2  
Effective: 3-6-2006

**SOUTHERN IDAHO**  
Issued: 2-24-2006

**109. OBSOLETE CENTRAL OFFICE SERVICES**

<b>SUBJECT</b>	<b>PAGE</b>	
Airport Intercommunicating Service .....	1	
Central Office Alarm Services.....	162	
Centrex 21 .....	135	
Centrex Plus Service .....	65	
<i>CENTRON I</i> .....	7	
<i>CENTRON 6 and 30 Service</i> .....	46	
<i>CENTRON Custom</i> .....	53	
Command Conference Service .....	160	
Customized Call Management Services (CCMS).....	9	
Customized Call Management Services/ <i>CENTRON I</i> Service .....	7	
Dial Switching Systems .....	1	
Emergency Reporting Service .....	156.1	(T)
Emergency Alarm and Reporting Service .....	157	
Optional Service Features .....	19	
Public Emergency Reporting Service - Small Office .....	157	
<i>VERSANET</i> Service .....	162	
Universal Emergency Number Service - 911 .....	156.1	(N)

NOTICE  
THE INFORMATION CONTAINED IN THIS DOCUMENT IS SUBJECT TO CHANGE.

## **109. OBSOLETE CENTRAL OFFICE SERVICES**

### **109.1 DIAL SWITCHING SYSTEMS**

#### **109.1.6 AIRPORT INTERCOMMUNICATING SERVICE**

The terms and conditions associated with the obsolescence of this service are the same as those specified for Centrex Plus Service in 109.1.16, following.

#### A. General

##### 1. Description

- a. Airport Intercommunicating Service is a special telephone service arrangement designed for the common use of airline companies and others located at airports who serve the air traveling public. The service is provided by common dial switching equipment, station lines, stations and attendant position equipment, as required. The arrangement contemplates inward and outward local and long distance calling without operator assistance. The service is available only on a flat rate basis.
- b. The service will be furnished at the rates and charges specified herein for customers located in the air terminal building and to others located within the airport service rate area who are engaged in providing service and facilities to the air traveling public. Customers qualifying for this service will be determined by the Company and shall exclude customers such as hotels, motels, banks, manufacturers, etc., who normally conduct their business at other locations. Regular exchange service may be provided within the airport service rate area as required.
- c. The airport service rate area shall include the land and buildings, surrounding the air terminal building, used in the operation of the airport. This land may be intersected by streets and/or alleys. The airport service rate area shall be defined by an airport service rate area map showing the boundaries of the area to be served under the rates and regulations specified herein.
- d. The CO switching equipment is provided in the type and quantity as determined by the Company.

**Qwest Corporation**  
**Exchange and Network**  
**Services Catalog No. 1**

**SECTION 109**  
Page 2  
Release 1

**SOUTHERN IDAHO**  
Issued: 7-1-2005

Effective: 8-1-2005

**109. OBSOLETE CENTRAL OFFICE SERVICES**

**109.1 DIAL SWITCHING SYSTEMS**

**109.1.6 AIRPORT INTERCOMMUNICATING SERVICE**

A.1. (Cont'd)

- e. Directory listings of Airport Intercommunicating Service customers will be provided in the regular telephone directory of the serving exchange, subject to the regulations, rates, and charges specified in Section 5 of this Catalog. An Airport Intercommunicating Service directory will also be published by the Company. Listings in this directory will be provided, without the charge, in the type, quantity, and arrangement necessary, in the opinion of the Company, to adequately identify the customer's service. Regular rates and regulations will apply to other listings.
- f. Long distance calls will be identified by telephone number on the customer's bill.
- g. The service will be provided with or without an attendant position at the option of the individual Airport Intercommunicating Service customer.
- h. Toll diverting service is not offered in connection with this service.
- i. The rates and charges specified below are applicable at airports having a requirements for 100 or more main station lines within the airport service rate area. The service will not be provided at locations where less than 100 main station lines are required.
- j. The basic station line rate schedule starts over again for each individual customer to Airport Intercommunicating Service.

**NOTICE**  
**THE INFORMATION CONTAINED IN THIS DOCUMENT IS SUBJECT TO CHANGE.**

## **109. OBSOLETE CENTRAL OFFICE SERVICES**

### **109.1 DIAL SWITCHING SYSTEMS**

#### **109.1.6 AIRPORT INTERCOMMUNICATING SERVICE**

##### A.1. (Cont'd)

- k. The station line rates specified herein are subject to the following regulations, mileage, and incremental charges as appropriate:
- Exchange Service Extension charges will not apply to stations (main or extension) located within the airport service rate area. Regular Exchange Service Extension charge treatment will apply to all extension station lines located outside of the airport service rate area.
  - The basic station line rate schedule starts over again at each location outside of the airport service rate area (RX3).
  - The incremental station line rate treatment specified for Centrex main station line service will apply where the airport service rate area and the main station are located in different central office districts of the same exchange (RGP/AP;RGU/).
  - In addition to the basic station line rates, the regular exchange zone rate area individual line business service increment, (ZNA), will apply to main stations located outside of the airport service rate area in exchange zone rate areas.
  - In connection with FX main station service the basic main station line rate schedule will apply to main stations at each FX station location. Each circuit required to serve the main stations at FX locations from the serving exchange will be treated as an individual line business service for the application of FX charges.
  - Where the airport service rate area is located in an exchange zone rate area, the exchange zone rate area individual line business service increment (ZNA) as appropriate, will apply to each main station served on a direct individual line basis in addition to the basic station rate schedule. In such cases, where the stations are associated with an attendant position, the incremental charges (ZNA) will apply to each circuit serving the attendant position and the basic station line rate schedule will apply to the stations located within the airport service rate area. The number of circuits serving the attendant position is determined on an engineered basis at the time the service is established and will remain unchanged until the engineered capacity of the position is changed at which time the incremental charge will be recomputed.

**Qwest Corporation**  
**Exchange and Network**  
**Services Catalog No. 1**

**SECTION 109**

Page 4

Release 1

**SOUTHERN IDAHO**  
Issued: 7-1-2005

Effective: 8-1-2005

**109. OBSOLETE CENTRAL OFFICE SERVICES**

**109.1 DIAL SWITCHING SYSTEMS**

**109.1.6 AIRPORT INTERCOMMUNICATING SERVICE**

A.1. (Cont'd)

- l. Touch-Tone rates and charges apply for attendant positions and associated station lines provided in connection with Airport Intercommunicating Service. The lines provided on a direct individual line basis will be considered as individual line business services.
- m. Incoming and/or outgoing lines terminated in ACD equipment associated with Airport Intercommunicating Service will be treated as regular flat 2-way CO trunks for the application of regulations, rates, and charges.
- n. Station lines associated with existing services, located within the airport service rate area, will be given appropriate number assignments and be connected to the Airport Intercommunicating Service system without charge.
- o. Airport Intercommunicating Service is offered only as a complete service. The exchange access and intercommunication portions of the Airport Intercommunicating Service main station line rates are not offered separately.
- p. The rates and charges for Computer Port Access specified elsewhere will apply to lines connected to customer-provided computer and/or computer systems equipment capable of information processing and/or storage.

**NOTICE**  
**THE INFORMATION CONTAINED IN THIS DOCUMENT IS SUBJECT TO CHANGE.**

## **109. OBSOLETE CENTRAL OFFICE SERVICES**

### **109.1 DIAL SWITCHING SYSTEMS**

#### **109.1.6 AIRPORT INTERCOMMUNICATING SERVICE**

##### A.1. (Cont'd)

- q. Airport Intercommunicating Service will not be furnished as a new service to any customer or applicant. The station lines, attendant positions and optional service features may be added to present systems so long as the existing switching equipment is capable of providing the additional requested service and the additional required equipment, if any, is available from existing or recovered stock.
- r. Station Lines
  - The rate and charge for a main or extension station line is applicable to each telephone jack termination or outlet of a main or extension station location, respectively, to which an instrument can be connected.
  - Rates and charges for Airport Intercommunicating Service do not include provision of telephones.
- s. Centrex Rate Stability Plan (RSP)

The Rate Stability Plan, as specified in 109.1.1, preceding, may be provided for Airport Intercommunicating Service in which all switching equipment is located on Company premises.

##### B. Basic Features

- Central Office Dial Switching Equipment
- Station Dial Transfer Feature

**Qwest Corporation**  
**Exchange and Network**  
**Services Catalog No. 1**

**SECTION 109**  
Page 6  
Release 1  
Effective: 8-1-2005

**SOUTHERN IDAHO**  
Issued: 7-1-2005

**109. OBSOLETE CENTRAL OFFICE SERVICES**

**109.1 DIAL SWITCHING SYSTEMS**

**109.1.6 AIRPORT INTERCOMMUNICATING SERVICE (Cont'd)**

C. Rates and Charges

1. The basic station line rates specified below include the common dial switching equipment, power plan, necessary CO trunks and station dial transfer feature.
2. The total rate, per main station line, is the sum of the appropriate exchange access and intercommunication rate.

AIRPORT DIAL STATION LINES (CO)	USOC	NON-RECURRING CHARGE	MONTHLY RATE STABILITY CHARGE	MONTHLY RATE
• First 5 main station lines, each				
- Exchange access	RXR	\$44.00	–	\$ 9.82
- Intercommunication and station line	NRX	11.00	\$15.50	27.96
• Next 45 main station lines, each				
- Exchange access	RXR	44.00	–	9.82
- Intercommunication and station line	NRX	11.00	13.50	21.17
• Next 250 main station lines, each				
- Exchange access	RXR	44.00	–	8.49
- Intercommunication and station line	NRX	11.00	11.50	14.45
• Additional main station lines, each				
- Exchange access	RXR	44.00	–	7.37
- Intercommunication and station line	NRX	11.00	9.50	13.21
• Extension station line, each	RX7	–	3.25	7.17

**NOTICE**  
**THE INFORMATION CONTAINED IN THIS DOCUMENT IS SUBJECT TO CHANGE.**

## **109. OBSOLETE CENTRAL OFFICE SERVICES**

### **109.1 DIAL SWITCHING SYSTEMS (Cont'd)**

#### **109.1.7 CUSTOMIZED CALL MANAGEMENT SERVICES/CENTRON I SERVICE**

##### A. *CENTRON I* Service

*CENTRON I* Service Optional Features are forwarded from a Stored Program Controlled central office. *CENTRON I* is the offering available to residence customers. The following *CENTRON I* Service Optional Features are grandfathered and available only to existing customers.

##### 1. Optional Features

###### Alternate Answering - (Call Forwarding-Busy Line/Don't Answer)[1]

This feature automatically transfers incoming calls that encounter a (1) busy condition and/or a (2) don't answer condition after a preselected number of rings (from 1 to 7) to an alternate designated line.

###### Alternate Answering - (Call Forwarding-Busy Line) (Residence Only)[1]

This feature automatically transfers incoming calls that encounter a busy condition to an alternate designated line.

###### Intercom

A user of the *CENTRON I* Service can dial up to six (6) or thirty (30) other lines in the same package by dialing an access code followed by one or two digits. Two user stations with the same line number cannot access each other utilizing the Intercom feature.

[1] When it is determined that a subscriber to Alternate Answering is forwarding calls to a residence line from a business line to the extent that the primary use of the residence line is substantially of a business nature, the residence line will be reclassified as business service and business rates will apply.

**Qwest Corporation**  
**Exchange and Network**  
**Services Catalog No. 1**

**SECTION 109**  
Page 8  
Release 1

**SOUTHERN IDAHO**  
Issued: 7-1-2005

Effective: 8-1-2005

**109. OBSOLETE CENTRAL OFFICE SERVICES**

**109.1 DIAL SWITCHING SYSTEMS**

**109.1.7 CUSTOMIZED CALL MANAGEMENT SERVICES/CENTRON I SERVICE**

A. *CENTRON I* Service (Cont'd)

2. Rates

	<b>USOC</b>	<b>MONTHLY RATE RESIDENCE</b>
• Alternate Answering - (Call Forwarding-Busy Line/Don't Answer), per line	MVPAA	\$1.35
• Alternate Answering - (Call Forwarding-Busy Line), per line (Residence Only)	MVPBL	0.35
• Intercom - 6#, per system	MVP1N	0.30
• Intercom - 30#, per system	MVP1C	—

**NOTICE**  
**THE INFORMATION CONTAINED IN THIS DOCUMENT IS SUBJECT TO CHANGE.**

**Qwest Corporation**  
**Exchange and Network**  
**Services Catalog No. 1**

**SECTION 109**  
Page 9  
Release 1  
Effective: 8-1-2005

**SOUTHERN IDAHO**  
Issued: 7-1-2005

**109. OBSOLETE CENTRAL OFFICE SERVICES**

**109.1 DIAL SWITCHING SYSTEMS**

**109.1.7 CUSTOMIZED CALL MANAGEMENT SERVICES/CENTRON I SERVICE**  
**(Cont'd)**

B. Customized Call Management Services (CCMS)

Effective April 11, 2005, CCMS is obsolete and is not available to new customers. Customers will be allowed to retain their obsolete service only as long as service remains at the same location for the same customer.

1. Description

- a. Customized Call Management Services (CCMS) is composed of standard and optional features furnished from a Stored Program Controlled central office. CCMS is available to individual line business customers wishing to combine one or more exchange access lines into a group.
- b. CCMS is available to individual line business and residence customers where technically feasible. CCMS may be incompatible with some services due to technical limitations.
- c. A customer may choose to combine access lines terminating at different locations into a single CCMS package. All access lines terminating in CCMS Service, however, must be served by the same central office.
- d. Flat Rate Service and Message or Measured Rate Service access lines may not be mixed in the same CCMS package.
- e. The combination of residence and business access lines is allowed. When a CCMS system contains both residence and business access lines only one residence access line is permitted. In addition, no hunting or call forward busy line features will be permitted between the business and residence access lines.
- f. The quality of transmission for calls utilizing CCMS Call Forwarding or CCMS/ Conferencing may vary depending on the distance and routing involved. The Company makes no representation as to the quality of the transmission on such calls.

**NOTICE**  
**THE INFORMATION CONTAINED IN THIS DOCUMENT IS SUBJECT TO CHANGE.**

**Qwest Corporation**  
**Exchange and Network**  
**Services Catalog No. 1**

**SECTION 109**

Page 10

Release 1

**SOUTHERN IDAHO**  
Issued: 7-1-2005

Effective: 8-1-2005

**109. OBSOLETE CENTRAL OFFICE SERVICES**

**109.1 DIAL SWITCHING SYSTEMS**

**109.1.7 CUSTOMIZED CALL MANAGEMENT SERVICES/*CENTRON* I SERVICE**

B.1. (Cont'd)

- g. CCMS standard and optional features cannot be used in combination with the following Custom Calling services; Call Waiting, Call Forwarding - Variable, Three Way Calling, Speed Call 8 and Speed Call 30.
- h. CCMS is allowed only with Touch-Tone equipped access lines.
- i. Where Message or Measured Service exchange access lines terminate in CCMS, message charges are not applied to calls completed utilizing the Intercom feature.
- j. 800 Service circuit terminating on a CCMS can be furnished with CCMS standard and optional features the excluding intercom feature.
- k. The nonrecurring charge will not apply when changing from existing *CENTRON* 6 and 30 Service to CCMS.

NOTICE  
THE INFORMATION CONTAINED IN THIS DOCUMENT IS SUBJECT TO CHANGE.

**Qwest Corporation**  
**Exchange and Network**  
**Services Catalog No. 1**

**SECTION 109**  
Page 11  
Release 1

**SOUTHERN IDAHO**  
Issued: 7-1-2005

Effective: 8-1-2005

---

**109. OBSOLETE CENTRAL OFFICE SERVICES**

**109.1 DIAL SWITCHING SYSTEMS**

**109.1.7 CUSTOMIZED CALL MANAGEMENT SERVICES/*CENTRON I* SERVICE**

B. Customized Call Management Services (CCMS) (Cont'd)

2. Standard Features

Touch-Tone

Touch-Tone Calling Service is a distinctive type of telephone service using audible voice frequency tones to actuate the CO equipment, and is provided as a part of the standard package.

CONSULTLINE

A user of CCMS can place any established call on hold by dialing a control code. This frees the line to originate another call or use the call pickup feature.

User Transfer

The user of CCMS can transfer any established call to another line within or outside the package.

Conferencing

The user of CCMS can hold an in progress call and complete a second call while maintaining privacy from the first call. In addition, the user may choose to add on the previously held call into a three-way conference.

NOTICE  
THE INFORMATION CONTAINED IN THIS DOCUMENT IS SUBJECT TO CHANGE.

## **109. OBSOLETE CENTRAL OFFICE SERVICES**

### **109.1 DIAL SWITCHING SYSTEMS**

#### **109.1.7 CUSTOMIZED CALL MANAGEMENT SERVICES/CENTRON I SERVICE**

##### **B. Customized Call Management Services (CCMS) (Cont'd)**

##### **3. Optional Features**

###### Alternate Answering - (Busy Line) (Business Only)[1]

This feature automatically transfers incoming calls that encounter a busy condition to an alternate designated line.

###### Alternate Answering - (Don't Answer) (Business Only)[1]

This feature automatically transfers incoming calls that encounter a don't answer condition after a preselected number of rings (from 1 to 7) to an alternate designated line.

###### Alternate Answering - (Call Forwarding-Busy Line/Don't Answer)[2]

This feature automatically transfers incoming calls that encounter a (1) busy condition and/or a (2) don't answer condition after a preselected number of rings (from 1 to 7) to an alternate designated line.

###### Call Forwarding - (Variable)

This feature allows the user to program automatic transfer of all calls made to the called line to a different line, within or outside the CCMS group.

###### Call Pickup Group

This feature enables a user of CCMS to answer a call which has been directed to another line in the package.

[1] When it is determined that a subscriber to Alternate Answering is forwarding calls to a residence line from a business line to the extent that the primary use of the residence line is substantially of a business nature, the residence line will be reclassified as business service and business rates will apply.

[2] This feature became obsolete prior to April 11, 2005.

## **109. OBSOLETE CENTRAL OFFICE SERVICES**

### **109.1 DIAL SWITCHING SYSTEMS**

#### **109.1.7 CUSTOMIZED CALL MANAGEMENT SERVICES/CENTRON I SERVICE**

##### B.3. (Cont'd)

##### Call Rejection (Business Only)

This feature enables a business customer to reject call attempts from up to 15 numbers of calling parties by dialing a code and the telephone numbers of calls to be rejected. Any call attempts to the customer from these numbers will be prevented from terminating to the customer and will instead be connected to an announcement informing the caller that the call is not presently being accepted by the called party. A customer may also reject future calls from the most recent call received by dialing a code after completing the call.

##### Call Waiting

This feature provides a tone alert to a CCMS user who is on an existing call that another call is waiting.

##### Continuous Redial (Business Only)

This feature allows a business customer to dial a code that will cause the feature to automatically redial the last number the customer dialed. If the called number is busy, the feature will redial the called number for a limited period of time. A tone alerts the customer when the called number becomes available.

##### Convenience Dialing

This feature allows a user to abbreviate dialing patterns for frequently called and emergency numbers. By dialing an access code of one or two digits, a customer can dial up to six (6) or thirty (30) preprogrammed numbers. All lines in a package may share the same (30) number list or the (30) number may be available to an individual line only. The (6) number list is available only on an individual line basis. Convenience Dialing (6) can only be combined with Intercom (30) on the same line or Convenience Dialing (30) can only be combined with Intercom (6).

## **109. OBSOLETE CENTRAL OFFICE SERVICES**

### **109.1 DIAL SWITCHING SYSTEMS**

#### **109.1.7 CUSTOMIZED CALL MANAGEMENT SERVICES/CENTRON I SERVICE**

##### B.3. (Cont'd)

##### Intercom[1]

A user of the CCMS can dial up to six (6) or thirty (30) other lines in the same package by dialing an access code followed by one or two digits. Two user stations with the same line number cannot access each other utilizing the Intercom feature.

##### Last Call Return (Business Only)

This feature allows a business customer to dial a code that will cause the feature to automatically redial the number of the last incoming call to that line, whether the call was answered or not. The customer does not have to know the number of the calling party. If the called number is busy, the feature will redial the called number for a limited period of time. A tone alerts the customer when the called line is available.

##### Priority Call (Business Only)

This feature allows a business customer to assign a maximum of 15 callers' telephone numbers to a special list. The customer will hear a distinctive ring at their location, when calls are received from callers' telephone numbers on that list.

##### Programmable Call Forwarding-Busy Line (Business Only)

This feature allows a CCMS customer to have incoming calls forwarded to another number when the called number is busy. The CCMS customer can activate and deactivate the forwarding feature by dialing a code. The CCMS customer can also establish or change the number to which calls will be forwarded.

[1] This feature became obsolete prior to April 11, 2005.

## **109. OBSOLETE CENTRAL OFFICE SERVICES**

### **109.1 DIAL SWITCHING SYSTEMS**

#### **109.1.7 CUSTOMIZED CALL MANAGEMENT SERVICES/CENTRON I SERVICE**

##### B.3. (Cont'd)

##### Programmable Call Forwarding-Don't Answer (Business only)

This feature allows a CCMS customer to have incoming calls forwarded to another number if the customer does not answer after a preset number of ringing cycles. The CCMS customer can activate and deactivate the forwarding feature by dialing a code and can establish or change the number to which calls will be forwarded.

##### Selective Call Forwarding (Business Only)

This feature allows a business customer to specify a special list of a maximum of 15 telephone numbers. Incoming calls placed to the customer from telephone numbers on that list will automatically be forwarded to a predefined telephone number. All other calls will be handled normally.

##### Six-Way Conferencing (Business only)

This feature permits the CCMS customer to establish a Conference Call with up to six conferees, including the originator. Conferees may be inside or outside the CCMS system. This feature is available where technically feasible.

#### 4. Rates and Charges - General

- a. The nonrecurring charge for business customers applies per line, per customer request to:
  - (1) Establish Standard Feature Package.
  - (2) Establish optional feature(s) and miscellaneous line terminating arrangements unless adding at the same time Standard Feature Package is established.
  - (3) Change optional feature(s) in an existing arrangement.

**NONRECURRING  
CHARGE**

- Business

\$12.00

**Qwest Corporation**  
**Exchange and Network**  
**Services Catalog No. 1**

**SECTION 109**  
Page 16  
Release 1  
Effective: 8-1-2005

**SOUTHERN IDAHO**  
Issued: 7-1-2005

**109. OBSOLETE CENTRAL OFFICE SERVICES**

**109.1 DIAL SWITCHING SYSTEMS**

**109.1.7 CUSTOMIZED CALL MANAGEMENT SERVICES/CENTRON I SERVICE**

B.4.a. (Cont'd)

- (4) The nonrecurring charge will not apply to:
- discontinue all optional features
  - discontinue one or more features when the remaining feature(s) stay the same.
- b. The following USOCs are for CCMS and are in addition to the USOCs for access lines and other services or equipment with which they are associated.

	<b>USOC</b>	<b>MONTHLY RATE BUSINESS</b>
(1) Standard Feature Package, per line	MVP11	\$6.00
(2) Optional Features		
• Alternate Answering - (Call Forwarding - Busy Line), per line (Business Only)	MVPBL	4.00
• Alternate Answering - (Call Forwarding - Don't Answer), per line (Business Only)	MVPDA	2.50
• Call Forwarding - Variable, per line	MVPCF	4.00
• Call Pickup Group, per line	MVPCU	1.00
• Call Rejection, per line (Business Only)	MVPSR	3.50

**NOTICE**  
**THE INFORMATION CONTAINED IN THIS DOCUMENT IS SUBJECT TO CHANGE.**

**Qwest Corporation**  
**Exchange and Network**  
**Services Catalog No. 1**

**SECTION 109**  
Page 17  
Release 1  
Effective: 8-1-2005

**SOUTHERN IDAHO**  
Issued: 7-1-2005

**109. OBSOLETE CENTRAL OFFICE SERVICES**

**109.1 DIAL SWITCHING SYSTEMS**

**109.1.7 CUSTOMIZED CALL MANAGEMENT SERVICES/CENTRON I SERVICE**

B.4.a.(2) (Cont'd)

	<b>USOC</b>	<b>MONTHLY RATE BUSINESS</b>
• Call Waiting, per line	MVPCW	\$5.50
• Continuous Redial, per line (Business Only)	MVPAC	2.50
• Convenience Dialing - 6# List, per list, each	MBWCD	2.00
• Convenience Dialing - 30# List, per list, each	MVPCD	2.50
• Last Call Return, per line (Business Only)	MVPAR	2.50
• Priority Call, per line (Business Only)	MVPDW	2.50
• Programmable Call Forwarding -Busy Line, per line (Business Only)	MVPCB	4.00
• Programmable Call Forwarding Don't Answer, per line (Business Only)	MVPCA	3.50
• Selective Call Forwarding, per line (Business Only)	MVPSF	2.50
• Six-Way Conferencing, per line (Business Only)	MVP6C	5.00

**NOTICE**  
**THE INFORMATION CONTAINED IN THIS DOCUMENT IS SUBJECT TO CHANGE.**

**Qwest Corporation**  
**Exchange and Network**  
**Services Catalog No. 1**

**SECTION 109**  
Page 18  
Release 1  
Effective: 8-1-2005

**SOUTHERN IDAHO**  
Issued: 7-1-2005

**109. OBSOLETE CENTRAL OFFICE SERVICES**

**109.1 DIAL SWITCHING SYSTEMS**

**109.1.7 CUSTOMIZED CALL MANAGEMENT SERVICES/CENTRON I SERVICE**

B.4.a.(2) (Cont'd)

	<b>USOC</b>	<b>MONTHLY RATE BUSINESS</b>
• Alternate Answering - (Call Forwarding-Busy Line/Don't Answer), per line[1]	MVPAA	\$4.50
• Intercom - 6#, per system[1]	MVP1N	3.00
• Intercom - 30#, per system[1]	MVP1C	4.12
(4) Miscellaneous Line Terminating Arrangements[2]		
• 800 Service Circuit, each Termination to main station line	WTK	2.00

[1] This feature became obsolete prior to April 11, 2005.

[2] In the event an incoming 800 service call is transferred to a remote location, transmission performance cannot be guaranteed.

**NOTICE**  
**THE INFORMATION CONTAINED IN THIS DOCUMENT IS SUBJECT TO CHANGE.**

## **109. OBSOLETE CENTRAL OFFICE SERVICES**

### **109.1 DIAL SWITCHING SYSTEMS (Cont'd)**

#### **109.1.10 OPTIONAL SERVICE FEATURES**

The terms and conditions associated with the obsolescence of this service are the same as those specified for Centrex Plus Service in 109.1.16, following.

##### **A. Description**

Optional Service Features in this section are obsolete and will not be offered to new customers as of February 20, 1992. Effective May 20, 1992, all Month-to-Month customers must convert to Centrex Plus Service. Existing contracted customers may continue to subscribe to Optional Service Features until their contract term expires. Maintenance will be provided for contracted systems.

1. The following optional service features are provided for Central Office Services which are furnished from Stored Program Control central offices, and are subject to the availability of facilities and generic feature programs. These optional features are in alphabetical order. Each feature has a description followed by the appropriate USOCs.
2. The provision of such facilities and programs will be determined by the Company based upon regular engineering practices and economic considerations.
3. Provisions of special arrangements and engineering required to make a feature(s) compatible with the customer's system will be based on cost plus contribution.
4. Obsolete Optional Service Features found in 109.1.10.D., following, will be offered only to Centrex and *CENTRON* customers.

**Qwest Corporation**  
**Exchange and Network**  
**Services Catalog No. 1**

**SECTION 109**  
Page 20  
Release 1  
Effective: 8-1-2005

**SOUTHERN IDAHO**  
Issued: 7-1-2005

---

**109. OBSOLETE CENTRAL OFFICE SERVICES**

**109.1 DIAL SWITCHING SYSTEMS**

**109.1.10 OPTIONAL SERVICE FEATURES**

A. Description (Cont'd)

5. Optional Services Features

- Automatic Callback
- Call Forwarding Busy Line
- Call Forwarding Don't Answer
- Call Forwarding Busy Line and Don't Answer
- Call Forwarding - Variable
- Call Forwarding via Private Facilities
- Call Hold
- Call Pick-Up
- Call Waiting - All Calls
- Call Waiting - Dial Originating
- *CENTRON* Management System
- Customer Changeable Speed Calling
- Distinctive Ringing/Distinctive Call Waiting Tone
- Flexible Route Selection (FRS)
- Hot Line
- Make Busy Arrangements

NOTICE  
THE INFORMATION CONTAINED IN THIS DOCUMENT IS SUBJECT TO CHANGE.

**Qwest Corporation**  
**Exchange and Network**  
**Services Catalog No. 1**

**SECTION 109**  
Page 21  
Release 1  
Effective: 8-1-2005

**SOUTHERN IDAHO**  
Issued: 7-1-2005

**109. OBSOLETE CENTRAL OFFICE SERVICES**

**109.1 DIAL SWITCHING SYSTEMS**

**109.1.10 OPTIONAL SERVICE FEATURES (Cont'd)**

B. Rates and Charges - General

1. Service and Equipment Charge - Optional Service Features

Service and equipment charges apply per USOC (unless specified otherwise), per customer request to establish or change one or more optional features as follows:

	<b>SERVICE &amp; EQUIPMENT CHARGE</b>
• Established with the initial installation of the system access line	\$0.65
• Established subsequent to the initial installation of the access line	6.50
• Feature change when other service and equipment charges do not apply	6.50
a. The service and equipment charge will not apply to:	
(1) Discontinue all optional features; or	
(2) Discontinue one or more optional feature(s) when the remaining feature(s) stay the same.	

NOTICE  
THE INFORMATION CONTAINED IN THIS DOCUMENT IS SUBJECT TO CHANGE.

**Qwest Corporation**  
**Exchange and Network**  
**Services Catalog No. 1**

**SECTION 109**  
Page 22  
Release 1  
Effective: 8-1-2005

**SOUTHERN IDAHO**  
Issued: 7-1-2005

**109. OBSOLETE CENTRAL OFFICE SERVICES**

**109.1 DIAL SWITCHING SYSTEMS**

**109.1.10 OPTIONAL SERVICE FEATURES**

B. Rates and Charges - General (Cont'd)

2. Service Establishment - Optional Service Features

A Service Establishment Charge applies per system for the following Optional Service Features.

	<b>USOC</b>	<b>SERVICE ESTABLISHMENT CHARGE</b>
• Automatic Callback	ACY	\$237.00
• Call Forwarding via Private Facilities	EAY	611.00
• Distinctive Ringing/Distinctive Call Waiting Tone	DRR	83.00

C. Feature Description

1. Automatic Callback

This feature enables a calling party encountering a busy station within the system to dial an activation code and be automatically called back when the called station becomes idle.

	<b>USOC</b>	<b>INSTALLATION CHARGE</b>	<b>MONTHLY RATE</b>
• Common equipment, per system[1]	ACY	\$65.00	\$3.03
• Per main station line	SAK	1.35	1.13

[1] Service establishment charge specified previously also applies.

**109. OBSOLETE CENTRAL OFFICE SERVICES**

**109.1 DIAL SWITCHING SYSTEMS**

**109.1.10 OPTIONAL SERVICE FEATURES**

C. Feature Description (Cont'd)

2. Call Forwarding Busy Line

This feature is available, where facilities permit. It automatically routes direct-in-dialed calls to a preselected station within the *CENTRON* group when the called station is busy.

	<b>USOC</b>	<b>INSTALLATION CHARGE</b>	<b>MONTHLY RATE</b>
• Per system	N/A	\$147.00	–
• Per main station line	E6GUR	–	\$0.26

3. Call Forwarding Don't Answer

This feature is available, where facilities permit. It automatically routes direct-in-dialed calls to a preselected station within the *CENTRON* group when the called station does not answer within a prescribed time.

	<b>USOC</b>	<b>INSTALLATION CHARGE</b>	<b>MONTHLY RATE</b>
• Per system	N/A	\$147.00	–
• Per main station line	E9GUR	–	\$2.57

**Qwest Corporation**  
**Exchange and Network**  
**Services Catalog No. 1**

**SECTION 109**  
Page 24  
Release 1  
Effective: 8-1-2005

**SOUTHERN IDAHO**  
Issued: 7-1-2005

**109. OBSOLETE CENTRAL OFFICE SERVICES**

**109.1 DIAL SWITCHING SYSTEMS**

**109.1.10 OPTIONAL SERVICE FEATURES**

C. Feature Description (Cont'd)

4. Call Forwarding Busy Line and Don't Answer

This feature provides for forwarding of incoming calls to a preselected station within the *CENTRON* group, when the called station is busy or does not answer after a predetermined number of ringing cycles.

	<b>USOC</b>	<b>INSTALLATION CHARGE</b>	<b>MONTHLY RATE</b>
• Per system	N/A	\$190.00	–
• Per main station line	E5E	–	\$2.73

5. Call Forwarding Variable

When activated by a station user, automatically routes that station's incoming calls to any other station he selects. The station selected may be the attendant.

	<b>USOC</b>	<b>INSTALLATION CHARGE</b>	<b>MONTHLY RATE</b>
• Per system	N/A	\$70.00	–
• Per main station line or attendant access line	EAT	–	\$1.08

**NOTICE**  
**THE INFORMATION CONTAINED IN THIS DOCUMENT IS SUBJECT TO CHANGE.**

**Qwest Corporation**  
**Exchange and Network**  
**Services Catalog No. 1**

**SECTION 109**  
Page 25  
Release 1  
Effective: 8-1-2005

**SOUTHERN IDAHO**  
Issued: 7-1-2005

**109. OBSOLETE CENTRAL OFFICE SERVICES**

**109.1 DIAL SWITCHING SYSTEMS**

**109.1.10 OPTIONAL SERVICE FEATURES**

C. Feature Description (Cont'd)

6. Call Forwarding via Private Facilities

a. Description

A main station line equipped with the Call Forwarding via Private Facilities feature provides for the automatic routing of incoming calls to a specific private facility which is terminated in that main station line user's system. As used herein, the term "private facility" applies to Common Control Switching Arrangement (CCSA), Enhanced Private Switching Communication System (EPSCS), Electronic Tandem Switching (ETS), Wide Area Telephone Service (WATS), Foreign Exchange (FX), and tie line arranged for senderized operation, and the local and toll message network.

b. Regulations

Incoming local and toll message network and INWATS calls to main station lines arranged for Call Forwarding via Private Facilities routing are subject to the appropriate charges for such calls and a common recorded announcement is furnished to inform the caller that the call is being forwarded.

Calls forwarded to the local and toll message network and WATS are subject to the appropriate charges for such calls.

	<b>USOC</b>	<b>INSTALLATION CHARGE</b>	<b>MONTHLY RATE</b>
• Common equipment, per system[1]	EAY	\$65.00	\$106.22
• Per main station line	EAP	2.75	5.92

[1] Service establishment charge specified previously also applies.

**Qwest Corporation**  
**Exchange and Network**  
**Services Catalog No. 1**

**SECTION 109**  
Page 26  
Release 1  
Effective: 8-1-2005

**SOUTHERN IDAHO**  
Issued: 7-1-2005

**109. OBSOLETE CENTRAL OFFICE SERVICES**

**109.1 DIAL SWITCHING SYSTEMS**

**109.1.10 OPTIONAL SERVICE FEATURES**

C. Feature Description (Cont'd)

7. Call Hold

Allows a station user to hold any call in progress, by dialing a code, thus freeing the line for the purpose of originating another call.

The optional service feature of call hold is common to each telephone in a basic multiline hunt group and the rates and charges specified for that feature apply to each telephone in the group.

	<b>USOC</b>	<b>INSTALLATION CHARGE</b>	<b>MONTHLY RATE</b>
• Per system	N/A	\$112.50	–
• Per main station line or each line in a multiline hunt group arranged	EAB	–	\$0.77

8. Call Pick-Up

Enables a station user to answer calls directed to other specified stations by dialing a special code. Those specified stations, known as a pick-up group, should generally be close enough together so that the ring of any station within the group can be heard by any other station in the group.

	<b>USOC</b>	<b>INSTALLATION CHARGE</b>	<b>MONTHLY RATE</b>
• Per system	N/A	\$61.00	–
• Per pick-up group	E3N	61.00	\$0.26
• Per main station line arranged	E3P	–	0.36
• Per main station line/non barge-in	E6D	–	0.10

**NOTICE**  
**THE INFORMATION CONTAINED IN THIS DOCUMENT IS SUBJECT TO CHANGE.**

**Qwest Corporation**  
**Exchange and Network**  
**Services Catalog No. 1**

**SECTION 109**  
Page 27  
Release 1

**SOUTHERN IDAHO**  
Issued: 7-1-2005

Effective: 8-1-2005

**109. OBSOLETE CENTRAL OFFICE SERVICES**

**109.1 DIAL SWITCHING SYSTEMS**

**109.1.10 OPTIONAL SERVICE FEATURES**

C. Feature Description (Cont'd)

9. Call Waiting - All Calls

This feature allows a user to be alerted that a call is waiting by applying a burst of tone when the user is busy on another call. The user may elect to answer the call by flashing the switchhook or by hanging up and being rung back.

	<b>USOC</b>	<b>INSTALLATION CHARGE</b>	<b>MONTHLY RATE</b>
• Per system	N/A	\$59.00	–
• Per main station line arranged	E6N	–	\$2.26

10. Call Waiting - Dial Originating

This feature provides the ability for the originating station to invoke call waiting service on selected calls by dialing the dial call waiting access code followed by the extension number of the station to be call waited.

	<b>USOC</b>	<b>INSTALLATION CHARGE</b>	<b>MONTHLY RATE</b>
• Per system	N/A	\$59.00	–
• Per main station line arranged	E6C	–	\$0.26

**NOTICE**  
**THE INFORMATION CONTAINED IN THIS DOCUMENT IS SUBJECT TO CHANGE.**

## **109. OBSOLETE CENTRAL OFFICE SERVICES**

### **109.1 DIAL SWITCHING SYSTEMS**

#### **109.1.10 OPTIONAL SERVICE FEATURES**

##### C. Feature Description (Cont'd)

#### 11. *CENTRON* Management System (CMS)

##### a. Description

CMS is a computer software program that provides the customer access to their data base for the purpose of general data base inquiry, move, add, delete and change features. In addition CMS enables the customer to move and change station lines and generate Basic Management Reports.

##### b. Feature List

#### (1) Standard Features

##### Inquiry

The ability to access a data base to review the status of station lines and features on the customer's system.

##### Move, Add, Delete and Change

The ability to perform station number changes and to move, add, delete or change most features on the system from customer-provided equipment located on the customer's premises.

##### Basic Management Reports

The ability to design and create management reports regarding the customer's system. These reports vary by switch type and may change with software updates.

## **109. OBSOLETE CENTRAL OFFICE SERVICES**

### **109.1 DIAL SWITCHING SYSTEMS**

#### **109.1.10 OPTIONAL SERVICE FEATURES**

##### C.11. (Cont'd)

#### (2) Optional Features

##### Custom Reports

Customers can request customized report formats to be created for various aspects of their system. Once created, the custom report is stored in the customer's data base and can be recalled at any time.

##### Priority Service

Allows customers to request "priority changes" which are then processed in the serving central office as soon as possible. Customers are limited to the number of priority requests that can be processed in one day.

##### Bulk Change

Allows customers to request the same change to be applied to multiple lines simultaneously. Customers may be limited to the number of changes in any single bulk change request in a single day.

##### Network Manipulation

Allows customers to manage certain Network features such as Automatic Route Selection, Time of Day Routing.

##### System Partitioning

The Company, upon the customer's request, can partition the CMS data base into separate sections representing different customer departments. Each partition can be arranged to be accessible only to certain users designated by the customer.

##### Packet Control Capability

Gives customers the ability to manage their packet control features. Customers that subscribe to Packet Control Capability can verify current and pending packet options, add, delete or change packet options and run reports regarding packet assignments.

**Qwest Corporation**  
**Exchange and Network**  
**Services Catalog No. 1**

**SECTION 109**  
Page 30  
Release 1  
Effective: 8-1-2005

**SOUTHERN IDAHO**  
Issued: 7-1-2005

**109. OBSOLETE CENTRAL OFFICE SERVICES**

**109.1 DIAL SWITCHING SYSTEMS**

**109.1.10 OPTIONAL SERVICE FEATURES**

C.11. (Cont'd)

c. Regulations

- (1) *CENTRON* Management System (CMS) will be offered to all customers under the following guidelines:
  - All month-to-month customers regardless of station line size will be provided CMS as an optional feature at rates and charges found in C.13.d., following.
  - All new contracted customers will be provided CMS as a standard feature. Service Establishment Charges found in C.13.d., following, will apply.
- (2) The Company will furnish and maintain CMS software for use by the customer and will be offered only where facilities permit.
- (3) The customer must obtain and maintain a compatible computer terminal for use with CMS. The computer terminal will not be furnished by the Company. A business exchange access line or *CENTRON* main station line is also required, which are in addition to the rates and charges for CMS.
- (4) CMS is available for access by the customer 22 hours a day, seven days a week, from the CMS data base. The Company reserves all rights to take the CMS computer down for maintenance or software updates as required. When possible, this will be done during off-peak hours and customers will be warned in advance. Move, Add, Delete and Change requests are processed once a day unless the customer subscribes to Priority Service.
- (5) The Company will process change requests, which have accumulated in the CMS throughout the day during off-peak load hours, overnight or at a customer specified future date. All normal and emergency central office functions have priority over customer requested changes. The Company assumes no responsibility for change requests delayed by such Company functions.

**NOTICE**  
**THE INFORMATION CONTAINED IN THIS DOCUMENT IS SUBJECT TO CHANGE.**

## **109. OBSOLETE CENTRAL OFFICE SERVICES**

### **109.1 DIAL SWITCHING SYSTEMS**

#### **109.1.10 OPTIONAL SERVICE FEATURES**

##### C.11.c. (Cont'd)

- (6) The Company will provide the customer a list of features able to be managed by CMS at the time of initial installation based upon the serving CO technology. The Company reserves the right to upgrade or change CMS at anytime. Any additional customer training or documentation requirements resulting from such changes will be A supplied at no charge.
- (7) The Company establishes parameters on the number of station lines that can be equipped with a feature, depending upon the quantity of features purchased. Information will be provided through CMS as to what these parameters are. The customer may add, move, delete or change features through CMS within such parameters. Additions beyond the parameters of CMS will not be processed.
- (8) New connects and disconnects of station lines are not permitted through CMS.
- (9) The customer assumes full responsibility for the features managed by CMS. The Company will not maintain a record of which features are on each line, but only a total count of the number of features purchased. For maintenance purposes, the Company will rely on remote access to the customer's CMS data base.
- (10) Since CMS software allows the customer to move and change station numbers within their system, the customer will be responsible for labeling the Network Interface when number changes occur. All maintenance calls to the Company in which the trouble proves to be other than on the Company side of the Network Interface will result in the application of appropriate Premises Work Charges, as specified elsewhere.[1]
- (11) The customer is not allowed to move or change station numbers extended outside of the central office serving the customer's system.
- (12) Initial training of the customer in the use of CMS is included at the time of initial installation.

[1] The appropriate Premises Work Charges, as specified elsewhere, will not apply to lines equipped with *UNISTAR* Service.

## **109. OBSOLETE CENTRAL OFFICE SERVICES**

### **109.1 DIAL SWITCHING SYSTEMS**

#### **109.1.10 OPTIONAL SERVICE FEATURES**

##### C.11. (Cont'd)

##### d. Rates and Charges

- (1) Service and Equipment Charges, found elsewhere, do not apply when the customer moves, activates, deactivates, changes features and moves or changes lines through CMS.
- (2) Features managed by CMS must be purchased in incremental blocks of 10 each. The total number of blocks of features purchased will be indicated on the customer's bill. The total number of features purchased must be within the limit established in the CMS.
- (3) Service and Equipment Charges, as specified elsewhere, will apply per feature USOC added to the CMS system.
- (4) Features added through CMS carry the same recurring rates, service establishment and system charges as if they were added through the conventional service order process and will be reflected on the customer's bill as such.
- (5) The charge per line for CMS applies to all lines on the customers system, even though some lines may be designated as not changeable.
- (6) When CMS is disconnected, Service and Equipment Charges, as specified elsewhere, will apply per line for all changes or rearrangements to system features.
- (7) If the customer moves his system from one CO to another, and station line number changes are involved, a subsequent charge to reestablish the CMS data base will apply.
- (8) A System Establishment Charge will apply to the initial *CENTRON* System installed. A discounted System Establishment Charge applies for subsequent associated systems.

**Qwest Corporation**  
**Exchange and Network**  
**Services Catalog No. 1**

**SECTION 109**  
Page 33  
Release 1

**SOUTHERN IDAHO**  
Issued: 7-1-2005

Effective: 8-1-2005

**109. OBSOLETE CENTRAL OFFICE SERVICES**

**109.1 DIAL SWITCHING SYSTEMS**  
**109.1.10 OPTIONAL SERVICE FEATURES**  
C.11.d. (Cont'd)

	USOC	NONRECURRING CHARGE	MONTHLY RATE
• System Establishment			
- Initial installation	MB5XX	\$1,000.00	-
- Subsequent installation for an associated system	CPVWO	500.00	-
• Standard Features			
- Inquiry, Move, Add, Delete, Change, Basic Management Reports, per line[1]	MB5XL	-	\$0.75
• Optional Features			
- Custom Reports[2]	RCVXX	ICB	-
- Priority Service	GREPX	2,500.00	-
- Bulk Change	FN6BX	2,500.00	-
- Network Manipulation	MB8NX	2,500.00	-
- System Partitioning[2]	PD8XX	ICB	-
- Packet Control Capability, per system	PTGPS	5,000.00	-

[1] See C.13.c.(1), following, for rate and charge applications

[2] Rates and charges will be based on an individual case basis per customer request.

**NOTICE**  
**THE INFORMATION CONTAINED IN THIS DOCUMENT IS SUBJECT TO CHANGE.**

**Qwest Corporation**  
**Exchange and Network**  
**Services Catalog No. 1**

**SECTION 109**  
Page 34  
Release 1  
Effective: 8-1-2005

**SOUTHERN IDAHO**  
Issued: 7-1-2005

**109. OBSOLETE CENTRAL OFFICE SERVICES**

**109.1 DIAL SWITCHING SYSTEMS**

**109.1.10 OPTIONAL SERVICE FEATURES**

C. Feature Description (Cont'd)

12. Customer Changeable Speed Calling

This feature allows subscribers to assign speed calling codes to their station lines.

	<b>USOC</b>	<b>INSTALLATION CHARGE</b>	<b>MONTHLY RATE</b>
• Speed call 6, per list	ESHC6	\$54.00	\$0.31
• Speed call 6, per main station line	EST1L	–	0.10
• Speed call 30, per list	ESHC3	54.00	0.31
• Speed call 30, per main station line	ESF1L	–	0.10

**NOTICE**  
**THE INFORMATION CONTAINED IN THIS DOCUMENT IS SUBJECT TO CHANGE.**

## **109. OBSOLETE CENTRAL OFFICE SERVICES**

### **109.1 DIAL SWITCHING SYSTEMS**

#### **109.1.10 OPTIONAL SERVICE FEATURES**

##### C. Feature Description (Cont'd)

#### 13. Distinctive Ringing/Distinctive Call Waiting Tone

##### a. Description

This feature enables a station user to determine the source of a call incoming to the station.

##### b. Regulations

Distinctive Ringing and Call Waiting Tone are furnished in different classes which permit main station line users to identify the source of calls as follows:

<b>CLASS</b>	<b>CALL SOURCE</b>
A	- Intercommunication
B	- Direct inward dialed local and toll - Attendant completed - CCSA access line - Voice D circuit

Distinctive ringing is furnished to indicate the source of calls to idle main station lines. Distinctive tone is furnished to indicate the source of calls to busy main station lines equipped for Call Waiting optional service features.

A distinctive ringing/tone is furnished to each class and is used to identify all call sources within each class.

Class A ringing/tone is not furnished separately and is included at no additional charge to main station lines arranged for Class B ringing/tone.

**Qwest Corporation**  
**Exchange and Network**  
**Services Catalog No. 1**

**SECTION 109**  
Page 36  
Release 1  
Effective: 8-1-2005

**SOUTHERN IDAHO**  
Issued: 7-1-2005

**109. OBSOLETE CENTRAL OFFICE SERVICES**

**109.1 DIAL SWITCHING SYSTEMS**

**109.1.10 OPTIONAL SERVICE FEATURES**

C.13. (Cont'd)

c. Rates and Charges[1]

	<b>USOC</b>	<b>INSTALLATION CHARGE</b>	<b>MONTHLY RATE</b>
• Common Equipment, per system	DRR	\$131.00	\$0.41
• Class B Ringing/Tone, per main station line	BRT	2.75	2.06

14. Flexible Route Selection (FRS)

a Description

FRS is an optional feature, available where facilities permit that allows station users, by dialing a preselected code, to automatically select the preferred route subscribed for by a customer, for network calls. Alternate routing to other facilities subscribed for by the customer, is also provided. This arrangement is available for use with FX, WATS, CCSA, and MTS Network.

FRS is accessed by dialing a single code (1, 2, or 3 digits) which automatically selects the appropriate route to complete the call. If all facilities in the initial route selected are busy, the call will advance to other routes in the selected pattern. Patterns may consist of up to four (4) private routes. If no route is available, the call will route to the selected long distance carrier or overflow tone at the customer's option.

The routing may be based on a number plan area (NPA) or specific CO codes within an NPA as designated by the customer. This is referred to as six (6) digit translation.

[1] Service establishment charge specified previously applies.

## **109. OBSOLETE CENTRAL OFFICE SERVICES**

### **109.1 DIAL SWITCHING SYSTEMS**

#### **109.1.10 OPTIONAL SERVICE FEATURES**

##### C.14. (Cont'd)

##### b. Regulations

All rates and charges specified for FRS are in addition to the rates and charges for the associated facilities.

Preferred routes and alternate routing patterns will be specified by the customer.

The number of patterns required by a customer is governed by the type and variety of facilities to which the customer subscribes. The maximum number of patterns is 64.

A pattern may have either the selected carrier or overflow tone as a final route. Dial 9 may be used as an access code only if the patterns accessed have the selected carrier as a final route.

A route cannot be used more than once in the same pattern.

The customer is responsible for notifying the Company whenever any additions or changes of routes or patterns are required.

##### c. Explanation of Terms

###### Route

A route is a group of one or more facilities of the same type used to complete 7 or 10 digit calls between the same points, (e.g., 1 FX or 3 WATS Band 1 lines, or 2 WATS Band 5 lines, or 1 CCSA, etc.). A WATS Band 1 and a WATS Band 5 are considered to be two routes.

###### Route Selection

The automatic selection of the preferred route as predetermined by the customer, upon dialing of an access code by the station user.

###### Pattern

A group of routes arranged to be selected in a sequence specified by the customer.

**Qwest Corporation**  
**Exchange and Network**  
**Services Catalog No. 1**

**SECTION 109**  
Page 38  
Release 1  
Effective: 8-1-2005

**SOUTHERN IDAHO**  
Issued: 7-1-2005

**109. OBSOLETE CENTRAL OFFICE SERVICES**

**109.1 DIAL SWITCHING SYSTEMS**  
**109.1.10 OPTIONAL SERVICE FEATURES**  
C.14.c. (Cont'd)

Six (6) Digit Translation

The screening of a specific group of digits to determine proper call routing. Where the calls are limited to specific CO designations within the NPA, the NPA code and the CO code (the first 6 digits) must be screened. This is referred to as 6 digit translation.

d. Rates and Charges

	<b>USOC</b>	<b>INSTALLATION CHARGE</b>	<b>MONTHLY RATE</b>
• Flexible Route Selection[1]			
- Common Equipment, per customer group	ABB	\$525.00	\$66.87
• Route Selection Patterns			
- Per Pattern, each[2]	ABK	120.00	4.12
- To overflow tone, per pattern each	ABW	120.00	10.29
- Per 6 digit translator, per NPA	ABM	54.00	4.12

[1] Each WATS Band is treated as a separate route.

[2] Where a toll restricted station line accesses a pattern whose final route is the MTS, overflow to MTS will not occur.

**NOTICE**  
**THE INFORMATION CONTAINED IN THIS DOCUMENT IS SUBJECT TO CHANGE.**

**Qwest Corporation**  
**Exchange and Network**  
**Services Catalog No. 1**

**SECTION 109**  
Page 39  
Release 1

**SOUTHERN IDAHO**  
Issued: 7-1-2005

Effective: 8-1-2005

**109. OBSOLETE CENTRAL OFFICE SERVICES**

**109.1 DIAL SWITCHING SYSTEMS**

**109.1.10 OPTIONAL SERVICE FEATURES**

C. Feature Description (Cont'd)

15. Hot Line

Allows equipped station to automatically place a call to a preassigned number by going off-hook.

	<b>USOC</b>	<b>INSTALLATION CHARGE</b>	<b>MONTHLY RATE</b>
• Per system	N/A	\$60.00	–
• Per line equipped	ETV	–	\$1.03

16. Toll Restriction

	<b>USOC</b>	<b>SERVICE &amp; EQUIPMENT CHARGE</b>	<b>MONTHLY RATE</b>
• Per system	N/A	\$16.45	–
• Per main station line restricted	ETB	6.00	\$1.02

**NOTICE**  
**THE INFORMATION CONTAINED IN THIS DOCUMENT IS SUBJECT TO CHANGE.**

## **109. OBSOLETE CENTRAL OFFICE SERVICES**

### **109.1 DIAL SWITCHING SYSTEMS**

#### **109.1.10 OPTIONAL SERVICE FEATURES**

##### C. Feature Description (Cont'd)

#### 17. Automatic Route Selection (ARS)

##### a. Description

ARS is a Centrex-CO optional feature, available where facilities permit, that allows station users, by dialing a preselected code, to automatically select the preferred route subscribed for by a customer, for network calls. Alternate routing to other facilities, subscribed for by the customer, is also provided. This arrangement is available for use with FX, WATS, CCSA OFF-NET and MTS Network.

ARS is accessed by dialing a single code (1, 2 or 3 digits) which automatically selects the appropriate route (FX, WATS, CCSA OFF-NET or the MTS Network) to complete the call. If all facilities in the initial route selected are busy, the call will advance to other routes in the selected pattern. Patterns may consist of up to four (4) private routes. If no route is available, the call will route to the MTS Network or overflow tone at the customer's option. All patterns accessed by a single access code will have the same final route, either the MTS Network or overflow tone.

For calls using FX, WATS or CCSA OFF-NET facilities, the routing may be based on a number plan area (NPA) and limited to specified CO codes within the NPA as designated by the customer. This is referred to as foreign area discrete translation.

##### b. Regulations

ARS is offered only to Centrex-CO customers served from No. 1 ESS central offices equipped to furnish this feature, where facilities permit.

All rates and charges specified for ARS are in addition to the rates and charges for the associated facilities.

Preferred routes and alternate routing patterns will be specified by the customer.

## **109. OBSOLETE CENTRAL OFFICE SERVICES**

### **109.1 DIAL SWITCHING SYSTEMS**

#### **109.1.10 OPTIONAL SERVICE FEATURES**

##### C.17.b. (Cont'd)

The number of patterns required by a customer is governed by the type and variety of facilities to which the customer subscribes.

A single rate per facility will apply regardless of the number of patterns having access to that facility. The monthly rate specified is applicable to each facility available to the patterns.

A group of patterns may have either the MTS Network as a final route or overflow tone. A combination of both within the same pattern group, that is, a group of patterns accessed by one code, is not permitted. Dial 9 may be used as an access code only if the patterns accessed have the MTS Network as a final route.

Patterns without final route to the MTS Network may be offered only if a customer subscribes to a sufficient number of facilities which, in the judgment of the Company, provide an adequate level of service so as to avoid interfering with the service of others or to prevent others from making or receiving calls over their telephone service.

Where toll restricted stations have access to ARS patterns with final route to the MTS Network, rates and charges as specified for patterns with overflow to tone apply in lieu of the charges specified for final route to the MTS Network.

Where a route is used in one pattern (pattern reached by one access code) only one translation may be provided per route. Where a route is used in two or more patterns (each pattern is accessed by different access codes) one translation per pattern may be provided subject to the appropriate charges as specified herein.

Voice D Circuits or circuit groups, as set forth in the Access Service Catalog will not be included as routes in patterns.

The customer is responsible for notifying the Company whenever any additions or changes of routes, patterns or facilities are required.

## **109. OBSOLETE CENTRAL OFFICE SERVICES**

### **109.1 DIAL SWITCHING SYSTEMS**

#### **109.1.10 OPTIONAL SERVICE FEATURES**

##### C.17. (Cont'd)

##### c. Definitions

###### Facility

A facility denotes a specific FX, CCSA or WATS circuit.

###### Route

A route is a group of one or more facilities of the same type used to complete 7 or 10 digit calls between the same points, e.g., 1 FX or 3 WATS Band 1 lines, or 2 WATS Band 5 lines, or 1 CCSA, etc. A WATS Band 1 and a WATS Band 5 are considered to be two routes. Exception: Where a customer has WATS Route Advance, the route capacity of a pattern is only reduced by one route.

###### Route Selection

The automatic selection of the preferred route is predetermined by the customer, upon dialing of an access code by the Centrex station user.

###### Pattern

A group of routes arranged to be selected in a sequence specified by the customer.

###### Foreign Area Discrete Translation

Provides the screening of a specific group of digits, by the Centrex switcher, to determine proper call routing. Where the calls are limited to specific CO designations within the NPA, the NPA code and the CO code (the first 6 digits) must be screened. This is referred to as 6 digit translation.

**Qwest Corporation**  
**Exchange and Network**  
**Services Catalog No. 1**

**SECTION 109**  
Page 43  
Release 1

**SOUTHERN IDAHO**  
Issued: 7-1-2005

Effective: 8-1-2005

**109. OBSOLETE CENTRAL OFFICE SERVICES**

**109.1 DIAL SWITCHING SYSTEMS**

**109.1.10 OPTIONAL SERVICE FEATURES**

C.17. (Cont'd)

d. Rates and Charges

	<b>USOC</b>	<b>INSTALLATION CHARGE</b>	<b>MONTHLY RATE</b>
• Common Equipment			
- Per customer group Per No. 1 ESS switching equipment	ART	\$758.75	\$236.04
• Route Selection Patterns			
- Per facility terminated in patterns, each	AR5	11.00	5.48
- By NPA code only, with final route			
- To the MTS Network, per pattern each	AR9	166.25	13.25

**NOTICE**  
**THE INFORMATION CONTAINED IN THIS DOCUMENT IS SUBJECT TO CHANGE.**

**Qwest Corporation**  
**Exchange and Network**  
**Services Catalog No. 1**

**SECTION 109**  
Page 44  
Release 1  
Effective: 8-1-2005

**SOUTHERN IDAHO**  
Issued: 7-1-2005

**109. OBSOLETE CENTRAL OFFICE SERVICES**

**109.1 DIAL SWITCHING SYSTEMS**  
**109.1.10 OPTIONAL SERVICE FEATURES**  
C.17.d. (Cont'd)

	<b>INSTALLATION CHARGE</b>
• Additions, deletions or changes of routes in existing patterns, per pattern[1]	\$166.25
- Addition of patterns, per pattern	[2]
- Addition or deletion of a facility to an existing route	-
- Additions or changes in NPA or CO code screening, per route[1]	227.50

[1] Each WATS band is treated as a separate route.

[2] Same rates and charges as specified for route selection patterns.

**NOTICE**  
**THE INFORMATION CONTAINED IN THIS DOCUMENT IS SUBJECT TO CHANGE.**

**Qwest Corporation**  
**Exchange and Network**  
**Services Catalog No. 1**

**SECTION 109**  
Page 45  
Release 1  
Effective: 8-1-2005

**SOUTHERN IDAHO**  
Issued: 7-1-2005

**109. OBSOLETE CENTRAL OFFICE SERVICES**

**109.1 DIAL SWITCHING SYSTEMS**  
**109.1.10 OPTIONAL SERVICE FEATURES**  
C.17.d. (Cont'd)

	USOC	NONRECURRING CHARGE
ARS Design Recommendation		
• Tape summarization procedure, per occasion[1,2]		
- First 10000 calls	ARXTP	\$1,310.00
- Each additional 1000 calls	ARXTP	19.80
• Manual input procedure, per occasion[1,2]		
- First 10000 calls	ARXMP	1,165.00
- Each additional 1000 calls	ARXMP	5.85
• Subsequent ARS Design Recommendation		
- First 10000 calls, tape	ARXTP	1,800.00
- Each additional 1000 calls, tape	ARXTP	55.00
- First 10000 calls, manual	ARXMP	1,600.00
- Each additional 100 calls, manual	ARXMP	33.33

[1] These charges are applicable each time the (TEARS) program is used.

[2] At the request of the customer, the Company will provide an ARS design recommendation based upon the traffic data available and configured utilizing Company traffic engineering principles. The charges shown for this service apply per occasion and include provision of the data to the customer in Company printed copy format. The accuracy of the recommendation provided to the customer is dependent upon the data available and the assumptions used, and should not be construed as a guarantee of future performance. The customer is responsible to advise the Company of the ARS design to be used.

**NOTICE**  
**THE INFORMATION CONTAINED IN THIS DOCUMENT IS SUBJECT TO CHANGE.**

## **109. OBSOLETE CENTRAL OFFICE SERVICES**

### **109.1 DIAL SWITCHING SYSTEMS (Cont'd)**

#### **109.1.12 CENTRON 6 AND 30 SERVICE**

##### A. Description

1. *CENTRON* 6 and 30 Service are optional features furnished from a Stored Program Controlled central office available to individual line business and residence customers wishing to combine two to thirty exchange access lines into a group (Obsolete - See 109.1.12.A.15., following). *CENTRON* 6 and 30 Service require special central office equipment and are not provided in all central offices. The Company may furnish *CENTRON* 6 and 30 Service where there is available central office equipment with the proper program updates, as determined by the Company.
2. *CENTRON* 6 and 30 Service cannot be used with remote switching systems (RSS), Centrex services, or other *CENTRON* services. In addition, *CENTRON* 6 and 30 Service cannot be used on trunks, or with Public Communications Service, multiparty service, InterLATA Foreign Exchange (FX) service, or Outward WATS.
3. Level access on a *CENTRON* 6 or 30 Service is not allowed.
4. A customer may choose to combine access lines terminating at different locations into a single *CENTRON* 6 or 30 package. All access lines. Terminating in *CENTRON* 6 or 30 Service however, must be served by the same central office.
5. Flat Rate Service and Message or Measured Rate Service access lines may not be mixed in the same *CENTRON* 6 or 30 package. The combination of residence and business access lines is allowed.
6. The quality of transmission for calls utilizing *CENTRON* 6 or 30 Call Forwarding or *CENTRON* 6 or 30 Conferencing may vary depending on the distance and routing involved. The Company makes no representation as to the quality of the transmission on such calls.
7. *CENTRON* 6 and 30 Service standard and optional features cannot be used in combination with existing Custom Calling services.
8. *CENTRON* 6 or 30 Service are allowed only with Touch-Tone equipped access lines.

## **109. OBSOLETE CENTRAL OFFICE SERVICES**

### **109.1 DIAL SWITCHING SYSTEMS**

#### **109.1.12 CENTRON 6 AND 30 SERVICE**

##### A. Description (Cont'd)

9. Where Message or Measured Service exchange access lines terminate in *CENTRON* 6 or 30 Service, message charges are not applied to calls completed utilizing the Intercom feature.
10. Suspension of service will not be allowed for *CENTRON* 6 or 30 Service.
11. *CENTRON* 6 and 30 Service will not be provided as a new service to any customer or applicant with a single individual line as of May 10, 1984. These services presently being furnished on a one-line basis to existing customer may be continued in service on the same premises for the same customer. Additional features may be added to the present system so long as the central office facilities are available.
12. When *CENTRON* 6 or 30 Service is provided on lines arranged for Companion Line service, all lines in the hunt group must be equipped for *CENTRON* 6 or 30 Service.
13. The minimum service period for *CENTRON* 6 or 30 Service is one month.
14. 800 Service circuit terminating on a *CENTRON* 6 or 30 Service can be furnished with *CENTRON* 6 or 30 Service standard and optional features excluding the intercom feature.
15. Effective January 11, 1990, *CENTRON* 6 and 30 Service is obsolete for business customers. Effective August 1, 1990, *CENTRON* 6 and 30 Service is obsolete for residence customers. Existing *CENTRON* 6 and 30 Service residence and business customers may continue their service on the same premises for the same customer. New installations, changes or moves will be converted to CCMS/*CENTRON* I Service. Service and Equipment and Nonrecurring charges will be waived for conversions of existing services.

##### B. Standard Features

###### 6 Intercom

A user of the *CENTRON* 6 Service can dial up to five (5) other lines in the same package by dialing an access code followed by a single digit. Two user stations with the same line number cannot access each other utilizing the Intercom feature.

## **109. OBSOLETE CENTRAL OFFICE SERVICES**

### **109.1 DIAL SWITCHING SYSTEMS**

#### **109.1.12 CENTRON 6 AND 30 SERVICE**

##### **B. Standard Features (Cont'd)**

##### **30 Intercom**

A user of the *CENTRON* 30 Service can dial up to twenty-nine (29) other lines in the same package by dialing an access code followed by two digits. Two user stations with the same line number cannot access each other utilizing the Intercom feature.

##### Touch-Tone

Touch-Tone Calling Service is a distinctive type of telephone service using audible voice frequency tones to actuate the CO equipment, and is provided as a part of the standard package.

##### Call Hold

A user of *CENTRON* 6 or 30 Service can place any established call on hold by dialing a control code. This frees the line to originate another call or use the call pickup feature.

##### Call Pickup Group

This feature enables a user of *CENTRON* 6 or 30 Service to answer a call which has been directed to another line in the package. Additional Call Pickup Groups are available as an optional feature.

##### User Transfer

The user of *CENTRON* 6 or 30 Service can transfer any established call to another line within or outside the package.

##### Conferencing

The user of *CENTRON* 6 or 30 Service can hold an in progress call and complete a second call while maintaining privacy from the first call. In addition, the user may choose to add on the previously held call into a three-way conference.

## **109. OBSOLETE CENTRAL OFFICE SERVICES**

### **109.1 DIAL SWITCHING SYSTEMS**

#### **109.1.12 CENTRON 6 AND 30 SERVICE (Cont'd)**

##### C. Optional Features

###### Additional Pick-Up Group

This feature enables a user of *CENTRON 6* or *30 Service* to answer a call which has been directed to another line in the package. These Call Pick-up Groups are in addition to the Call Pick-up Group provided as standard feature.

###### Call Waiting

This feature provides a tone alert to a *CENTRON 6* or *30 Service* user who is on an existing call that another call is waiting.

###### Call Forwarding

This feature allows the user to program automatic transfer of all calls made to the called line to a different line, within or outside the *CENTRON 6* or *30* group.

###### Alternate Answering - (Call Forwarding, Busy/Don't Answer)[1]

This feature automatically transfers incoming calls that encounter a (1) busy condition and/or a (2) don't answer condition after a preselected number of rings (from 1 to 7) to an alternate designated line within the package.

###### Alternate Answering - (Busy Line)[1]

This feature automatically transfers incoming calls that encounter a busy condition to an alternate designated line within the package.

###### Alternate Answering - (Don't Answer)[1]

This feature automatically transfers incoming calls that encounter a don't answer condition after a preselected number of rings (from 1 to 7) to an alternate designated line within the package.

[1] When it is determined that a subscriber to Alternate Answering is forwarding calls to a residence line from a business line to the extent that the primary use of the residence line is substantially of a business nature, the residence line will be reclassified as business service and business rates will apply.

**Qwest Corporation**  
**Exchange and Network**  
**Services Catalog No. 1**

**SECTION 109**  
Page 50  
Release 1  
Effective: 8-1-2005

**SOUTHERN IDAHO**  
Issued: 7-1-2005

**109. OBSOLETE CENTRAL OFFICE SERVICES**

**109.1 DIAL SWITCHING SYSTEMS**

**109.1.12 CENTRON 6 AND 30 SERVICE**

C. Optional Features (Cont'd)

CENTRON 6 Convenience Dialing

This feature allows a user to abbreviate dialing patterns for frequently called and emergency numbers. By dialing an access code and two digits, a customer can dial up to thirty (30) preprogrammed numbers. All lines in a package may share the same list or the list may be available to an individual line only. Customers may make changes to their list by dialing special codes.

CENTRON 30 Convenience Dialing

Same as *CENTRON 6* Convenience Dialing above except that a *CENTRON 30* Service customer can only dial up to six (6) preprogrammed numbers by dialing an access code and single digit.

D. Rates and Charges - General

The following USOCs are for *CENTRON 6* or *30* Service only and are in addition to the USOCs for access lines and other services or equipment with which they are associated.

	<b>USOC</b>	<b>MONTHLY RATE</b>
1. Standard Features		
• <i>CENTRON 6</i> Service (2 thru 6 lines), per line	MVP	\$6.17
• <i>CENTRON 30</i> Service (2 thru 30 lines), per line	MVPAL	9.26

**NOTICE**  
**THE INFORMATION CONTAINED IN THIS DOCUMENT IS SUBJECT TO CHANGE.**

**Qwest Corporation**  
**Exchange and Network**  
**Services Catalog No. 1**

**SECTION 109**  
Page 51  
Release 1

**SOUTHERN IDAHO**  
Issued: 7-1-2005

Effective: 8-1-2005

**109. OBSOLETE CENTRAL OFFICE SERVICES**

**109.1 DIAL SWITCHING SYSTEMS**

**109.1.12 CENTRON 6 AND 30 SERVICE**

D. Rates and Charges - General (Cont'd)

	<b>USOC</b>	<b>MONTHLY RATE</b>	
		<b>RESIDENCE</b>	<b>BUSINESS</b>
2. <i>CENTRON</i> 6 and 30 Service			
Optional Features			
Additional Call Pickup, per group[1]	MVPCP	\$4.12	\$4.12
Call Waiting, per line[1]	MVPCW	5.50	3.09
Call Forwarding, per line[1]	MVPCF	4.00	2.80
Alternate Answering - (Call Forwarding - Busy Line/Don't Answer), per line[1]	MVPAA	4.50	1.35
Alternate Answering - (Call Forwarding - Busy Line), per line[1]	MVPBL	3.00	0.35
Alternate Answering - (Call Forwarding - Don't Answer), per line[1]	MVPDA	2.50	1.10
<i>CENTRON</i> 6 Convenience Dialing - 30# List, per list, each	MVPCD	2.50	3.50
<i>CENTRON</i> 30 Convenience Dialing - 6# List, per list, each	MBWCD	2.00	2.50

[1] This optional feature can be used with either *CENTRON* 6 or 30 Service.

**NOTICE**  
**THE INFORMATION CONTAINED IN THIS DOCUMENT IS SUBJECT TO CHANGE.**

**Qwest Corporation**  
**Exchange and Network**  
**Services Catalog No. 1**

**SECTION 109**  
Page 52  
Release 1  
Effective: 8-1-2005

**SOUTHERN IDAHO**  
Issued: 7-1-2005

**109. OBSOLETE CENTRAL OFFICE SERVICES**

**109.1 DIAL SWITCHING SYSTEMS**

**109.1.12 CENTRON 6 AND 30 SERVICE**

D. Rates and Charges - General (Cont'd)

	<b>USOC</b>	<b>MONTHLY RATE</b>	
		<b>RESIDENCE</b>	<b>BUSINESS</b>
3. Miscellaneous Line Terminating Arrangements[1]			
• 800 Service Circuit, each termination to main station line	WTK	\$2.00	\$2.00
4. Training on Customer Premises			
If customers request training on their premises, the charges will apply per 1 hour session.			
Training Category			
			<b>NONRECURRING CHARGE</b>
• Station Users, each session			\$120.00
5. Documentation			
The customer is provided the following documentation to promote an understanding and an ongoing operative knowledge of system:			
• Initially, a supply of self paced user instruction booklets and dialing instruction cards will be provided for each system (one per equipped station).			
• Subsequently, additional copies will be provided based upon customer needs.			

[1] In the event an incoming 800 service call is transferred to a remote location, transmission performance cannot be guaranteed.

**NOTICE**  
**THE INFORMATION CONTAINED IN THIS DOCUMENT IS SUBJECT TO CHANGE.**

## **109. OBSOLETE CENTRAL OFFICE SERVICES**

### **109.1 DIAL SWITCHING SYSTEMS (Cont'd)**

#### **109.1.13 CENTRON CUSTOM**

##### A. Description

*CENTRON* Custom Service is obsolete and will not be offered to new customers as of February 20, 1992. Effective May 20, 1992, all Month-to-Month customers must convert to other appropriate service. Existing contracted customers may continue to subscribe to *CENTRON* Custom Service until their contract term expires. Maintenance will be provided for contracted systems. The terms and conditions associated with the obsolescence of this service are the same as those specified for Centrex Plus Service in 109.1.16, following.

1. *CENTRON* Custom is a business communications system furnished only from a Stored Program Controlled central office and is offered subject to the availability of facilities and applicable generic feature programs. Network access is provided through Network Access Registers as found in 5.3.3, preceding. The provision of such facilities and programs will be determined by the Company based upon regular engineering practices and economic considerations.

*CENTRON* Custom is so arranged as to provide the following basic service features:

- a. Direct inward and outward dialing of exchange and long distance message network calls from stations and attendant positions.
- b. Intercommunication between station lines of the same *CENTRON* Custom system.
- c. Identification, by main station line number on the customer's bill, of outgoing and incoming collect long distance message network calls.
- d. Call transfer-all calls, provides for all transfers including DID to DOD, consultation hold and add-on for any established call without the assistance of an attendant.

**Qwest Corporation**  
**Exchange and Network**  
**Services Catalog No. 1**

**SECTION 109**  
Page 54  
Release 1

**SOUTHERN IDAHO**  
Issued: 7-1-2005

Effective: 8-1-2005

**109. OBSOLETE CENTRAL OFFICE SERVICES**

**109.1 DIAL SWITCHING SYSTEMS**

**109.1.13 CENTRON CUSTOM**

A.1. (Cont'd)

- e. Main station line series completion and multiline hunting.[1]
  - f. Common recorded announcement for interception of calls to unassigned station numbers.
  - g. Touch-Tone calling provided on station lines.
  - h. Trunk answer any station for incoming primary listed directory calls.
2. Miscellaneous lines are those lines which are not a basic part of the *CENTRON* Custom system, i.e., CCSA, Voice D circuits, WATS, etc., but which require *CENTRON* Custom switching capabilities in order to function with *CENTRON* Custom service. Each miscellaneous line that is terminated in a *CENTRON* Custom system requires a termination arrangement.
  3. Main station line features may be provided for attendant access lines where facilities permit.
  4. Group Use Service provides intercommunication capability for different customers to dial one another by way of a four or five digit number provided the different customers are served from the same serving central office.
  5. Features
    - a. Standard *CENTRON* Custom features allowed on main station lines:
      - Restrictions (line Class of Service)
      - Semi Restricted
      - Non Restricted
      - Toll Restriction
      - Hunting
      - Series Sequential
      - Series Non Sequential
      - Multiline
      - Flexible Station Hunting (2B ESS)

[1] Hunting requirements differ by type of office.

**Qwest Corporation**  
**Exchange and Network**  
**Services Catalog No. 1**

**SECTION 109**  
Page 55  
Release 1  
Effective: 8-1-2005

**SOUTHERN IDAHO**  
Issued: 7-1-2005

**109. OBSOLETE CENTRAL OFFICE SERVICES**

**109.1 DIAL SWITCHING SYSTEMS**

**109.1.13 CENTRON CUSTOM**

A. Description (Cont'd)

	LINE CLASS CODE	
	FLAT	MEASURED
6. <i>CENTRON</i> provides the following standard main line classes of service.		
• Non Restricted - Station may originate calls to intra group stations, and the message network. This class of service may receive all types of calls.	RNN	RM1
• Non Restricted Outgoing - Semi Restricted terminating - Station may originate calls to intragroup stations and the message network. This class of service may receive calls from intragroup stations only.	RNS	RM2
• Non Restricted Outgoing - Deny terminating - Station may originate calls to intragroup stations, and the message network. This class of service cannot receive any calls.	RND	RM3
• Semi Restricted Outgoing - Non Restricted terminating - Station may originate calls to intragroup stations. This class of service may receive all types of calls.	RSN	RSN
• Semi Restricted Outgoing - Deny terminating - Station may originate calls to intragroup stations. This class of service cannot receive any calls.	RSD	RSD
• Semi Restricted Outgoing - Semi Restricted Incoming - Station may originate and receive calls from intragroup stations.	RS1	RS1

NOTICE  
THE INFORMATION CONTAINED IN THIS DOCUMENT IS SUBJECT TO CHANGE.

**Qwest Corporation**  
**Exchange and Network**  
**Services Catalog No. 1**

**SECTION 109**  
Page 56  
Release 1  
Effective: 8-1-2005

**SOUTHERN IDAHO**  
Issued: 7-1-2005

**109. OBSOLETE CENTRAL OFFICE SERVICES**

**109.1 DIAL SWITCHING SYSTEMS**

**109.1.13 CENTRON CUSTOM**

A.6. (Cont'd)

	LINE CLASS CODE	
	FLAT	MEASURED
<ul style="list-style-type: none"> <li>• Deny Origination - Non Restricted terminating - Station cannot originate any calls. Station may receive all types of calls.</li> </ul>	RDN	RDN
<ul style="list-style-type: none"> <li>• Deny Origination - Semi Restricted terminating - Station cannot originate any calls. Station may receive calls from intragroup stations.</li> </ul>	RDS	RDS
<ul style="list-style-type: none"> <li>• Toll Restricted Origination - Non Restricted terminating - Station may originate local 7 digit, 911 emergency, 1+411 local information, 1+800 Inwats, and repair service calls only. Station may terminate all types of calls.</li> </ul>	RTR	RM7
<ul style="list-style-type: none"> <li>• 800 Service terminated - the station is the switching telephone number (semi restricted origination).</li> </ul>	RIW	RIW
<ul style="list-style-type: none"> <li>• 800 Service main station line terminated - The station is the switching telephone number (non-restricted origination).</li> </ul>	RIN	RIN
<ul style="list-style-type: none"> <li>• 800 Service attendant terminated - the attendant station is the switching telephone number.</li> </ul>	RIX	RIX

NOTICE  
THE INFORMATION CONTAINED IN THIS DOCUMENT IS SUBJECT TO CHANGE.

**Qwest Corporation**  
**Exchange and Network**  
**Services Catalog No. 1**

**SECTION 109**  
Page 57  
Release 1

**SOUTHERN IDAHO**  
Issued: 7-1-2005

Effective: 8-1-2005

---

**109. OBSOLETE CENTRAL OFFICE SERVICES**

**109.1 DIAL SWITCHING SYSTEMS**

**109.1.13 CENTRON CUSTOM**

A. Description (Cont'd)

7. All classes of service with the exception of Deny Origination, are allowed access to Voice D circuits, CCSA, and WATS etc., providing the station is translated with the proper category codes.
8. New line class code screening may be negotiated, providing the office is capable of the arrangement requested.
9. The network demarcation for *CENTRON* Custom is the point at which the entrance facilities to the building, office park or buildings within a campus environment are initially terminated. *CENTRON*-Custom service and features are provided up to the network demarcation at rates and charges specified herein. The customer will be responsible for provision of all wire and/or cable facilities on the customer's side of the network demarcation. Any such facilities installed by the Company will be provided on a time and materials basis.

NOTICE  
THE INFORMATION CONTAINED IN THIS DOCUMENT IS SUBJECT TO CHANGE.

## **109. OBSOLETE CENTRAL OFFICE SERVICES**

### **109.1 DIAL SWITCHING SYSTEMS**

#### **109.1.13 CENTRON CUSTOM (Cont'd)**

##### **B. Regulations**

1. All *CENTRON* Custom station lines must be associated with the main switching equipment. Satellite switching equipment is not offered with *CENTRON* Custom. Other switching systems connected to a *CENTRON* Custom system by Voice D circuit or group use arrangements are considered as separate systems and are billed as such.
2. Temporary suspension, either full or partial, of *CENTRON* Custom is not permitted.
3. Where an ESS served Centrex-CO customer elects to convert to *CENTRON* Custom, service and equipment charges do not apply to in-service station lines, terminating arrangements, and optional service features provided that (1) the customer's system continues to be served by the same switching equipment, (2) there is no interruption of service, and (3) there are no moves, changes or additions of such in service station lines, arrangements and features. The conversion fee is specified in C. Rates and Charges, following.
4. Customers will be responsible to furnish all premises wiring, terminal equipment and jacks used with the *CENTRON* Custom Service.
5. The rates and charges specified for *CENTRON* Custom are in addition to the regular rates and charges for the services with which the *CENTRON* Custom is associated, e.g., WATS, CCSA, etc.
6. One primary directory listing is furnished without charge for each *CENTRON* Custom system. Directory listings of main station lines may be provided at the regular business additional listing rate (CLT) as specified in this catalog.
7. Transfer of calls will be provided on listed directory numbers on a total system disconnect only.
8. Customers not wishing to change their listed directory number to be part of a total *CENTRON* system may keep their existing number(s) as an option. See terminating listed directory numbers in this Section.
9. Loop Diversity, Avoidance and Fiber Optic Protect Path defined in the Access Service Catalog is available with *CENTRON* Custom Service.

**Qwest Corporation**  
**Exchange and Network**  
**Services Catalog No. 1**

**SECTION 109**  
Page 59  
Release 1  
Effective: 8-1-2005

**SOUTHERN IDAHO**  
Issued: 7-1-2005

---

**109. OBSOLETE CENTRAL OFFICE SERVICES**

**109.1 DIAL SWITCHING SYSTEMS**

**109.1.13 CENTRON CUSTOM (Cont'd)**

C. Rates and Charges - General

1. At the time a main station line is initially installed, it will be equipped with a main station line class of service, intercommunication, Touch-Tone and if desired, sequential, nonsequential or multiline hunting arrangement as determined jointly by the customer and the Company.
2. Applicable incremental charges as specified elsewhere in this Catalog apply.
3. The number of simultaneous exchange and long distance message network calls to and from main station line locations and attendant positions are controlled by the number of Network Access Registers.
4. In the event CO blocking occurs for a customer, a traffic measurement study will be required at rates and charges specified in 10.10.4, following. When the blocking is due to an increase in customer usage, additional Network Access Registers will be added and the customer billed accordingly.
5. *CENTRON* Custom network access is available on a flat and measured rate basis. The measured rate usage charges specified elsewhere in this Catalog apply.
6. The provision of network access is based on the use of Company specified number of Network Access Registers as required by the number of main station lines which will be determined on a customer by customer basis.

NOTICE  
THE INFORMATION CONTAINED IN THIS DOCUMENT IS SUBJECT TO CHANGE.

**Qwest Corporation**  
**Exchange and Network**  
**Services Catalog No. 1**

**SECTION 109**  
Page 60  
Release 1  
Effective: 8-1-2005

**SOUTHERN IDAHO**  
Issued: 7-1-2005

**109. OBSOLETE CENTRAL OFFICE SERVICES**

**109.1 DIAL SWITCHING SYSTEMS**  
**109.1.13 CENTRON CUSTOM (Cont'd)**

D. Rates and Charges - Common Equipment

Regular rates and charges will apply for Customer Training where applicable. All optional features may be used at appropriate rates and charges specified elsewhere; providing the serving CO is properly equipped and facilities are available.

1. Nonrecurring Charges

	USOC	NONRECURRING CHARGE
• Terminating listed directory numbers from outside the <i>CENTRON</i> Common block[1]	M5A	\$45.00

2. Common Equipment

	USOC	SERVICE & EQUIPMENT CHARGE	INSTALLATION CHARGE	MONTHLY RATE
• <i>CENTRON</i> Common Equipment, per system				
- Up to 100 lines	ERC	\$6.50	\$ 950.00	\$42.18
- 101 to 300 lines	ERC	6.50	2000.00	42.18

[1] The above charge is in addition to all other applicable charges for the main station line.

**NOTICE**  
**THE INFORMATION CONTAINED IN THIS DOCUMENT IS SUBJECT TO CHANGE.**

**Qwest Corporation**  
**Exchange and Network**  
**Services Catalog No. 1**

**SECTION 109**  
Page 61  
Release 1  
Effective: 8-1-2005

**SOUTHERN IDAHO**  
Issued: 7-1-2005

**109. OBSOLETE CENTRAL OFFICE SERVICES**

**109.1 DIAL SWITCHING SYSTEMS**

**109.1.13 CENTRON CUSTOM**

D. Rates and Charges - Common Equipment (Cont'd)

3. Main Station Lines

	<b>USOC</b>	<b>SERVICE &amp; EQUIPMENT CHARGE</b>	<b>MONTHLY RATE</b>
• Main station and intercommunication line terminated at customer's premises	EEA,EXO	\$47.50	[1]
• Off Premises Extension	EEF,EWT	47.50	[1]

4. Service and Equipment CO Change Charge

a. The following service and equipment charge for change applies:

	<b>SERVICE &amp; EQUIPMENT CHARGE</b>
• Per activity, per access line changed	\$27.50

[1] For *CENTRON* Custom Service rates and charges will be developed on the basis of each individual case for Intercommunication.

**NOTICE**  
**THE INFORMATION CONTAINED IN THIS DOCUMENT IS SUBJECT TO CHANGE.**

**109. OBSOLETE CENTRAL OFFICE SERVICES**

**109.1 DIAL SWITCHING SYSTEMS**

**109.1.13 CENTRON CUSTOM**

D. Rates and Charges - Common Equipment (Cont'd)

5. Miscellaneous Line Terminating Arrangements[1,2]

Provides for termination of special facilities into the system.

	USOC	INSTALLATION CHARGE	MONTHLY RATE
• Voice D Circuit, each	ESJ	\$46.00	\$81.28
• Tandem Voice D Circuit, each	ETM	46.00	95.68
• CCSA or OCC Access Line Circuit requiring Dedicated Trunk, each	ESO	46.00	31.89
• Foreign Exchange Circuit, each	ESQ	41.00	53.50
• WATS (outgoing) or WATS like service using FGD or SFG Circuit, each	ES2	41.00	3.09
• 800 Service Circuit, each terminated to main station line[3,4,5]	ETZ	41.00	3.09

[1] Not available in 2B ESS office.

[2] Where a *CENTRON* main station line is extended as a Voice D circuit to another switching system, the rates and charges specified for a *CENTRON* main station line apply in addition to the rates and charges specified for *CENTRON* Voice D circuit termination arrangement.

[3] For every four 800 service circuits terminated in a *CENTRON* System, network access registers should be increased by one.

[4] Each main station line terminating an incoming WATS Line will be restricted to intercom only.

[5] In the event an incoming 800 service call is transferred to a remote location, transmission performance cannot be guaranteed.

**NOTICE**  
**THE INFORMATION CONTAINED IN THIS DOCUMENT IS SUBJECT TO CHANGE.**

**Qwest Corporation**  
**Exchange and Network**  
**Services Catalog No. 1**

**SECTION 109**  
Page 63  
Release 1  
Effective: 8-1-2005

**SOUTHERN IDAHO**  
Issued: 7-1-2005

**109. OBSOLETE CENTRAL OFFICE SERVICES**

**109.1 DIAL SWITCHING SYSTEMS**

**109.1.13 CENTRON CUSTOM**

D. Rates and Charges - Common Equipment (Cont'd)

6. Digital Facility Interface

a. Description

This termination provides a digital interface for a high capacity (1.544 Mbps) facility which terminates to a customer's central office based switching system. This service provides for the connectivity of 24 circuits within the *CENTRON*/Centrex system.

b. Regulations

The rates and charges for the Digital Facility Interface are in addition to the rates and charges applicable for the appropriate high capacity facility. All current rules and regulations, including Federal regulations apply to the application of the high capacity facility.[1]

Digital Facility Interface will only be offered to *CENTRON*/Centrex customers, and will only provide for tie lines in a non-tandem configuration. This service is not provided on D4 channel banks.

	<b>USOC</b>	<b>SERVICE &amp; EQUIPMENT CHARGE[2]</b>	<b>INSTALLATION CHARGE[2]</b>	<b>MONTHLY RATE</b>
• Common Equipment[3]				
- Per digital interface unit, per 1.544 Mbps facility	D1E1X	\$255.00	\$540.00	\$270.00

[1] The High Capacity facility as found elsewhere should be rated as if it terminates to an end user's premises. The *CENTRON* in this case is the end user's premises.

[2] Applies on initial and subsequent activity.

[3] For *CENTRON* to *CENTRON* connections two Digital Facility Interfaces will be required, one at each end.

**NOTICE**  
**THE INFORMATION CONTAINED IN THIS DOCUMENT IS SUBJECT TO CHANGE.**

**Qwest Corporation**  
**Exchange and Network**  
**Services Catalog No. 1**

**SECTION 109**  
Page 64  
Release 1

**SOUTHERN IDAHO**  
Issued: 7-1-2005

Effective: 8-1-2005

**109. OBSOLETE CENTRAL OFFICE SERVICES**

**109.1 DIAL SWITCHING SYSTEMS**

**109.1.13 CENTRON CUSTOM**

D.6.b. (Cont'd)

	<b>USOC</b>	<b>SERVICE &amp; EQUIPMENT CHARGE[1]</b>	<b>INSTALLATION CHARGE[1]</b>	<b>MONTHLY RATE</b>
• Circuit Connections				
- <i>CENTRON</i> to <i>CENTRON</i>	M5P	\$8.50	\$12.00	\$20.00
- <i>CENTRON</i> to PBX/Key	M62	8.50	12.00	20.00
- <i>CENTRON</i> to Interexchange Carrier	M63	8.50	12.00	20.00

[1] Applies on initial and subsequent activity.

**NOTICE**  
**THE INFORMATION CONTAINED IN THIS DOCUMENT IS SUBJECT TO CHANGE.**

## **109. OBSOLETE CENTRAL OFFICE SERVICES**

### **109.1 DIAL SWITCHING SYSTEMS (Cont'd)**

#### **109.1.16 CENTREX PLUS SERVICE**

1. Effective February 5, 1996 Centrex Plus Service is grandfathered to current customers.
2. Current customers are:
  - a. Those customers with a Centrex Plus system(s) on record as of February 5, 1996,
  - b. Those customers for whom a written offer, documented proposal, or Request For Proposal (RFP) response has been provided by an authorized Company representative on or before February 5, 1996 and which offer terminates on the date stated on the offer, documented proposal, or RFP response. If no termination date is stated, the offer is hereby deemed terminated on May 5, 1996, or
  - c. Those customers who have signed a contract or for whom a service order has been issued on or before February 5, 1996, and whose service has not yet been installed.
3. The term of all existing contracts will be honored and extensions will be allowed as long as the extension period is no longer than the longest contract term allowed in the state. Multiple extensions will be allowed as long as they do not extend beyond April 29, 2005.
4. Contract extensions will be allowed at the same station rates as the contract being extended if these rates pass the then current price test. If prices need to be modified, they will be filed with the Commission, as appropriate.
5. Current customers may move, add, and change station lines and optional features at existing locations (premises). These moves, adds, and changes are allowed until
  - the customer moves to another service,
  - the contract expires, or
  - April 29, 2005.

**109. OBSOLETE CENTRAL OFFICE SERVICES**

**109.1 DIAL SWITCHING SYSTEMS**

**109.1.16 CENTREX PLUS SERVICE (Cont'd)**

Customers may add to their current station lines in a common block on record or identified in an authorized Company proposal as of February 5, 1996 as follows for the life of the grandfather term:

- 1-100 station lines ..... 100% growth every year
- 100 + station lines ..... 100% growth every two years

These numbers are not compounded.

Current customers may add no additional common blocks beyond those common blocks on record or identified in an authorized Company proposal as of February 5, 1996, except as follows:

- a. Customers may vacate and move locations which may require a common block to be changed.
- b. Customers purchasing a new business who want the acquired business location of record to have Centrex Plus Service.
- c. If the customer is a government entity, the customer may add new common blocks as part of plans to realign government functions.
- d. The Company reserves the right to monitor system efficiencies and perform necessary reconfigurations to enhance customer utilization of intercom dialing plans and abbreviated dialing features. This reconfiguration will not have the effect of increasing the total number of locations or lines except as otherwise allowed under the terms of the grandfathering provisions.

Current customers may add up to 20 additional locations (premises) annually for each of their common blocks.

6. Customers currently on month-to-month arrangements will be allowed to keep their current service at current rates or convert to a term Centrex Plus contract at the then current Centrex Plus term rate. Their rates, however, will be realigned at the time changes are made to the End User Common Line rates or if there is a change in the price test.

**Qwest Corporation**  
**Exchange and Network**  
**Services Catalog No. 1**

**SECTION 109**  
Page 67  
Release 1  
Effective: 8-1-2005

**SOUTHERN IDAHO**  
Issued: 7-1-2005

**109. OBSOLETE CENTRAL OFFICE SERVICES**

**109.1 DIAL SWITCHING SYSTEMS**

**109.1.16 CENTREX PLUS SERVICE (Cont'd)**

7. Should an existing Centrex Plus customer sell its business, its systems and contracts may be assigned subject to the assignee being bound by the terms and conditions set forth above.
8. Customers who currently have Centrex, *CENTRON* or another Centrex/*CENTRON*-like system and who have not yet converted to Centrex Plus, will be allowed to keep their current service at their current contract station rates until expiration of their contract. Their current Centrex, *CENTRON* or another Centrex/*CENTRON* -like service contract rates may be extended if these rates pass the then current price test. All other provisions cited above including those regarding limitations on common blocks, number of locations (premises) that can be added, and line and feature moves, adds, and changes will apply to these customers.
9. Current customers will be allowed to move to another service such as PBX trunks, individual business lines, or the new Centrex Service if it is available, etc., without termination liability penalty.
10. Any Centrex Plus orders taken after February 5, 1996 and for which there is not an outstanding proposal from a Company representative will be terminated at the time of Commission approval of the Company Centrex Plus discontinuance request. The customer must move to an alternative service. Although the alternative service arrangements may be different, the transition will occur without additional nonrecurring charges.

**NOTICE**  
**THE INFORMATION CONTAINED IN THIS DOCUMENT IS SUBJECT TO CHANGE.**

**Qwest Corporation**  
**Exchange and Network**  
**Services Catalog No. 1**

**SECTION 109**  
Page 68  
Release 1

**SOUTHERN IDAHO**  
Issued: 7-1-2005

Effective: 8-1-2005

**109. OBSOLETE CENTRAL OFFICE SERVICES**

**109.1 DIAL SWITCHING SYSTEMS**

**109.1.16 CENTREX PLUS SERVICE (Cont'd)**

A. Description

1. Centrex Plus Service is a business communications system furnished only from a Stored Program Controlled central office and is offered subject to the availability of facilities and applicable generic feature programs. A group of station lines is translated for an individual customer group and provides common access to a predetermined group of system features. Customers have a choice of access to the general network via each Centrex Plus station line (non-blocking) or controlled access (blocking) depending upon the number of Network Access Registers subscribed to by the customer as found in 5.3.3, preceding.
2. Centrex Plus standard features include the following features depending upon the serving central office:
  - Audible Message Waiting
  - Automatic Call Back
  - Call Forwarding - Busy Line
  - Call Forwarding - Don't Answer
  - Call Forwarding - Variable
  - Call Hold
  - Call Park
  - Call Pickup
  - Call Waiting
    - Call Forwarding of Call Waiting Calls
    - Dial Originating
    - Originating
    - Terminating
    - Cancel Call Waiting
  - Conference Calling
  - Data Call Protection
  - Direct Inward Dialing
  - Direct Outward Dialing
  - Distinctive Ringing/Distinctive Call Waiting Tone

**NOTICE**  
**THE INFORMATION CONTAINED IN THIS DOCUMENT IS SUBJECT TO CHANGE.**

**Qwest Corporation**  
**Exchange and Network**  
**Services Catalog No. 1**

**SECTION 109**  
Page 69  
Release 1

**SOUTHERN IDAHO**  
Issued: 7-1-2005

Effective: 8-1-2005

---

**109. OBSOLETE CENTRAL OFFICE SERVICES**

**109.1 DIAL SWITCHING SYSTEMS**

**109.1.16 CENTREX PLUS SERVICE**

A.2. (Cont'd)

- Executive Busy Override
- Hunting
- Individual Line Billing
- Intercept
- Intrasystem Calling
- Last Number Redial
- Line Restrictions
- Make Set Busy
- Network Speed Call
- Outgoing Trunk Queuing
- Speed Calling
- Three-Way Calling/Consultation Hold/Call Transfer - Touch-Tone
- Touch-Tone
- Trunk Answer Any Station (Night Service)

NOTICE  
THE INFORMATION CONTAINED IN THIS DOCUMENT IS SUBJECT TO CHANGE.

**Qwest Corporation**  
**Exchange and Network**  
**Services Catalog No. 1**

**SECTION 109**  
Page 70  
Release 1

**SOUTHERN IDAHO**  
Issued: 7-1-2005

Effective: 8-1-2005

**109. OBSOLETE CENTRAL OFFICE SERVICES**

**109.1 DIAL SWITCHING SYSTEMS**

**109.1.16 CENTREX PLUS SERVICE**

A. Description (Cont'd)

3. Centrex Plus optional features include the following features depending upon the serving central office:

- Account Codes
- Attendant Access Line Service
- Attendant Set Interface[1]
- Authorization Codes
- Automatic Route Selection (ARS)
  - Expensive Route Warning Tone
- Call Forward Don't Answer/Call Forward Busy Customer Programmable
- Call Forwarding via Private Facilities
- Centrex Management System (CMS)
- Direct Inward System Access (DISA)[1]
- Electronic Set Service[1]
  - Auto Answer Back
  - Automatic Dial
  - Automatic Line
  - Business Set Call Forward Per Key
  - Business Set Inspect Key
  - Call Forward Reason Display
  - Direct Station Selection/Busy Lamp Field
  - Display Called Number
  - Display Calling Number
  - Executive Message Waiting
  - Fast Transfer
  - Group Intercom
  - Group Intercom All Calls
  - Message Center
  - Message Waiting Set
  - Music on Hold - Electronic Set
  - Originating/Terminating Line Select
  - Privacy Release
  - Query Time
  - Station Camp-On

[1] Available only from a DMS-100 Central Office.

**Qwest Corporation**  
**Exchange and Network**  
**Services Catalog No. 1**

**SECTION 109**  
Page 71  
Release 1

**SOUTHERN IDAHO**  
Issued: 7-1-2005

Effective: 8-1-2005

---

**109. OBSOLETE CENTRAL OFFICE SERVICES**

**109.1 DIAL SWITCHING SYSTEMS**

**109.1.16 CENTREX PLUS SERVICE**

A.3. (Cont'd)

- Hot Line
- Loudspeaker Paging
- Message Waiting Visual
- Multiple Position Hunt
- Music on Hold[1]
- Remote Access
- Station Message Detail Recording
- Time of Day NCOS (Network Class of Service) Update[1]
- Time of Day Routing[1]
- Trunk Verification From Designated Station[1]
- Uniform Call Distribution

[1] Available only from a DMS-100 Central Office.

**NOTICE**  
**THE INFORMATION CONTAINED IN THIS DOCUMENT IS SUBJECT TO CHANGE.**

**Qwest Corporation**  
**Exchange and Network**  
**Services Catalog No. 1**

**SECTION 109**  
Page 72  
Release 1

**SOUTHERN IDAHO**  
Issued: 7-1-2005

Effective: 8-1-2005

---

**109. OBSOLETE CENTRAL OFFICE SERVICES**

**109.1 DIAL SWITCHING SYSTEMS**

**109.1.16 CENTREX PLUS SERVICE**

A. Description (Cont'd)

4. Miscellaneous facility terminations are those lines and trunks which are not a basic part of the Centrex Plus system, e.g., Voice Grade Circuits, WATS, etc., but which require Centrex Plus switching capabilities in order to function with Centrex Plus Service. Each miscellaneous line that is terminated in a Centrex Plus system requires a termination arrangement.
5. Main station line features may be provided for attendant access lines where facilities permit.
6. Split service common equipment is required when a Centrex Plus customer desires to segregate the Centrex Plus station lines into separate groups, thereby enabling each group to have a different set of system common features.
7. Centrex Plus Service and features are provided up to the network demarcation at rates and charges specified herein. The customer will be responsible for provision of all wire and/or cable facilities on the customer's side of the network demarcation. Any such facilities installed by the Company will be provided on a time and materials basis.

NOTICE  
THE INFORMATION CONTAINED IN THIS DOCUMENT IS SUBJECT TO CHANGE.

## **109. OBSOLETE CENTRAL OFFICE SERVICES**

### **109.1 DIAL SWITCHING SYSTEMS**

#### **109.1.16 CENTREX PLUS SERVICE (Cont'd)**

##### **B. Regulations**

1. All Centrex Plus station lines must be associated with the main switching equipment. Other switching systems connected to a Centrex Plus system by Voice Grade Circuits or group use arrangements are considered as separate systems and are billed as such.
2. Customer request for temporary suspension, either full or partial, of Centrex Plus Service is not permitted. Seasonal disconnects are allowed providing all rates and charges still apply.
3. Where a Stored Program Controlled *CENTRON* Custom customer elects to convert to Centrex Plus Service, nonrecurring charges do not apply to in-service station lines, terminating arrangements, and optional service features provided that (1) the customer's system continues to be served by the same switching equipment, (2) there is no interruption of service, and (3) there are no moves, changes or additions of such in service station lines, arrangements and features.
4. Customers will be responsible to furnish all premises wiring, terminal equipment and jacks used with the Centrex Plus Service.
5. The rates and charges specified for Centrex Plus are in addition to the regular rates and charges for the services with which the Centrex Plus is associated, e.g., WATS, Voice Grade Circuits, etc.
6. One primary directory listing is furnished without charge for each Centrex Plus system. Directory listings of main station lines may be provided at the regular business additional listing rate (CLT) as specified in 5.7.1, preceding.
7. Transfer of calls will be provided on listed directory numbers on a total system disconnect only.

**Qwest Corporation**  
**Exchange and Network**  
**Services Catalog No. 1**

**SECTION 109**  
Page 74  
Release 1

**SOUTHERN IDAHO**  
Issued: 7-1-2005

Effective: 8-1-2005

**109. OBSOLETE CENTRAL OFFICE SERVICES**

**109.1 DIAL SWITCHING SYSTEMS**

**109.1.16 CENTREX PLUS SERVICE**

B. Terms and Conditions (Cont'd)

8. Customers not wishing to change their listed directory number to be part of a total system may keep their existing number(s); however, there would be a Centrex Plus chip-in charge for translating listed directory numbers from outside the Centrex Plus customer group. Centrex Plus Service chip-in occurs when a non-sequential telephone number or block of numbers is added to a new or existing sequential Centrex Plus number arrangement.
9. Each customer will be required to sign a contractual agreement for the furnishing of services on a rate stabilized basis.
10. After the service date, a customer removing station lines in whole or in part, below a minimum line commitment quantity, will be subject to a termination charge. A service date will be considered the date of initial installation of station lines for a new system or the effective date of a contract renewal for existing systems. A minimum line commitment will be considered to be 60% of the number of lines initially installed and in service on the annual anniversary date of the Rate Stability Agreement. Company billing records will serve as documentation of the number of lines in service for the purpose of establishing the minimum line commitment. During the first year of a Rate Stability Agreement, the minimum line commitment will be based on the total number of lines in service 60 days after the first line is installed for a new system or the number of lines in service upon renewal of a Rate Stability Agreement for an existing system. In subsequent years of an agreement the minimum line commitment will be based on the number of lines in service on the anniversary date of the agreement. The anniversary date will be considered to be the date of the last signature executing the agreement or a date specified in the agreement.

Termination charges will only be applicable to Centrex Plus main station lines unless other applicable elements are noted in an agreement. Termination charges are not applied to common equipment, or optional features.

**NOTICE**  
**THE INFORMATION CONTAINED IN THIS DOCUMENT IS SUBJECT TO CHANGE.**

**Qwest Corporation**  
**Exchange and Network**  
**Services Catalog No. 1**

**SECTION 109**  
Page 75  
Release 1

**SOUTHERN IDAHO**  
Issued: 7-1-2005

Effective: 8-1-2005

**109. OBSOLETE CENTRAL OFFICE SERVICES**

**109.1 DIAL SWITCHING SYSTEMS**

**109.1.16 CENTREX PLUS SERVICE**

B. Regulations (Cont'd)

11. The Rate Stability Plan is subject to the terms of the Termination Liability/Waiver Policy set forth in 2.2.14.D., preceding.
12. Nonrecurring charges can be spread over the life of the contract at the present cost of money to the Company.
13. The customer may request a transfer of service from the customer premises location(s) to other customer premises location(s) within Qwest Corporation's fourteen (14) state service area. Qwest Corporation shall grant the customer's request if 1) necessary facilities are available; 2) the customer pays all uncollected costs associated with the original premises location including, but not limited to, stranded facilities costs, installation costs, labor costs, engineering costs, and service order charges; 3) the customer agrees to pay the recalculated monthly service charges and nonrecurring charges for the new location; 4) the move results in customer retaining in total the same or a greater number of Station Lines; 5) service is connected at the new location within thirty (30) days of the disconnect date at the old location; and 6) Qwest Corporation and the customer execute either a written Supplement to this Rate Stability Plan or a new Rate Stability Plan, as is appropriate, with a term that is at least equal to the remaining term of this Rate Stability Plan. If the move results in the customer retaining in total fewer Station Lines or if service is not connected at the new location(s) within thirty (30) days of the disconnect date at the old location(s); the termination charge applies as set forth in 2.2.14.D., preceding.
14. Customer Location

Customer primary location is that customer location within the area of their current serving CO designated on the customer's billing record.

Customer secondary location is a customer location other than the primary location served by one or more lines of the Centrex Plus system.

**NOTICE**  
**THE INFORMATION CONTAINED IN THIS DOCUMENT IS SUBJECT TO CHANGE.**

**Qwest Corporation**  
**Exchange and Network**  
**Services Catalog No. 1**

**SECTION 109**  
Page 76  
Release 1

**SOUTHERN IDAHO**  
Issued: 7-1-2005

Effective: 8-1-2005

**109. OBSOLETE CENTRAL OFFICE SERVICES**

**109.1 DIAL SWITCHING SYSTEMS**

**109.1.16 CENTREX PLUS SERVICE**

B. Regulations (Cont'd)

15. Centrex Plus Service is not available on Public Communications Service or multiparty service.
16. A customer may choose to combine station lines terminating at different locations into a single system. All station lines terminating in a system must be served by the same CO. Lines terminating or originating in different exchange or COs are subject to rates and charges found in the Access Services Catalog.
17. The quality of transmission for calls utilizing Call Forwarding or Conferencing may vary depending on the distance and routing involved.
18. Centrex Plus Service requires special CO equipment and is not provided in all COs. The Company may furnish Centrex Plus where there is available facilities and CO equipment, with the proper program updates, as determined by the Company.
19. Centrex Plus Optional Features will be furnished only where facilities permit as determined by the Company.
20. Centrex Plus telephone numbers may be sequential or nonsequential. Sequential numbers may be assigned if blocks of numbers are available and at the discretion of the Company.
21. Loop Diversity, Avoidance and Fiber Optic Protect Path defined in the Access Service Catalog is available with Centrex Plus Service.

**NOTICE**  
**THE INFORMATION CONTAINED IN THIS DOCUMENT IS SUBJECT TO CHANGE.**

**Qwest Corporation**  
**Exchange and Network**  
**Services Catalog No. 1**

**SECTION 109**  
Page 77  
Release 1

**SOUTHERN IDAHO**  
Issued: 7-1-2005

Effective: 8-1-2005

**109. OBSOLETE CENTRAL OFFICE SERVICES**

**109.1 DIAL SWITCHING SYSTEMS**

**109.1.16 CENTREX PLUS SERVICE (Cont'd)**

C. Rates and Charges - General

1. Each Centrex Plus station line will include the common line facility and the standard features as appropriate. Each station line will be equipped with 3-way calling, consultation hold, transfer, and intrasystem calling. The remaining standard features may be selected on a line-by-line basis as determined jointly by the customer and the Company.
2. Rates and charges for the common line facilities will be charged according to the number of station lines per location. Each different location will begin with the 1-20 station line charges. The common line facilities between 21-50 will have different rates and charges. Common line facilities for 51 station lines and over will be charged according to the distance of the station line from the serving central office, in quarter mile increments. Customers may add lines to a Centrex Plus system at the rates and charges in effect at the time the customer signed the Rate Stability Plan agreement.
3. Centrex Plus station lines, 50 and under located outside the Base Rate Area, will be subject to Outside the Base Rate Area Channel Connection rate found in the Access Service Catalog, in addition to the Common Line Facilities specified herein.
4. Centrex Plus rates and charges will be developed on an individual case basis when unique engineering and/or customer specified dedicated investment is required.

**NOTICE**  
**THE INFORMATION CONTAINED IN THIS DOCUMENT IS SUBJECT TO CHANGE.**

**Qwest Corporation**  
**Exchange and Network**  
**Services Catalog No. 1**

**SECTION 109**  
Page 78  
Release 1  
Effective: 8-1-2005

**SOUTHERN IDAHO**  
Issued: 7-1-2005

**109. OBSOLETE CENTRAL OFFICE SERVICES**

**109.1 DIAL SWITCHING SYSTEMS**  
**109.1.16 CENTREX PLUS SERVICE (Cont'd)**

D. Rates and Charges - Common Switching Elements

	<b>USOC</b>	<b>MONTHLY RATE</b>	
1. Miscellaneous Nonrecurring Charges			
• Change from blocking to non-blocking or non-blocking to blocking, per line	NR9CH	\$ 8.00	
• Centrex Plus Service Chip-in, per station line	REAJP	13.50	
2. Common Equipment[1]			
	<b>USOC</b>	<b>NONRECURRING CHARGE</b>	<b>MONTHLY RATE</b>
• Centrex Plus Common Equipment, per system	HYE	\$215.00	\$40.00
• Split Service Common Equipment, each	HYS	215.00	40.00

[1] This charge is in addition to all other applicable charges for the main station lines.

**NOTICE**  
**THE INFORMATION CONTAINED IN THIS DOCUMENT IS SUBJECT TO CHANGE.**

**Qwest Corporation**  
**Exchange and Network**  
**Services Catalog No. 1**

**SECTION 109**  
Page 79  
Release 1  
Effective: 8-1-2005

**SOUTHERN IDAHO**  
Issued: 7-1-2005

**109. OBSOLETE CENTRAL OFFICE SERVICES**

**109.1 DIAL SWITCHING SYSTEMS**

**109.1.16 CENTREX PLUS SERVICE**

D. Rates and Charges - Common Switching Elements (Cont'd)

3. Common Line Facilities, per location

		<b>USOC</b>
• Month-to-Month, blocked, each[1,2]		
- Flat main station line		RKY
- Flat extension station line		X5G
- DMS-100 Flat main station line, with visual message waiting[3]		RQ8
	<b>NONRECURRING CHARGE</b>	<b>MONTHLY RATE</b>
1 - 20 station lines	\$47.50	\$20.00
21 - 50 station lines	47.50	20.00
51 station lines and over	47.50	20.00

[1] End User Common Line applies to each Common Line Facility.

[2] Also apply rates and charges for Network Access Registers as found in 5.3.6, preceding.

[3] Available only from a DMS-100 Central Office. Requires the Optional Feature Message Waiting Visual as found elsewhere.

**NOTICE**  
**THE INFORMATION CONTAINED IN THIS DOCUMENT IS SUBJECT TO CHANGE.**

**Qwest Corporation**  
**Exchange and Network**  
**Services Catalog No. 1**

**SECTION 109**  
Page 80  
Release 1

**SOUTHERN IDAHO**  
Issued: 7-1-2005

Effective: 8-1-2005

**109. OBSOLETE CENTRAL OFFICE SERVICES**

**109.1 DIAL SWITCHING SYSTEMS**

**109.1.16 CENTREX PLUS SERVICE**

D.3. (Cont'd)

		<b>USOC</b>		
			<b>RHN</b>	
			<b>X5S</b>	
				<b>RQ5</b>
			<b>12</b>	<b>36</b>
			<b>TO</b>	<b>TO</b>
			<b>35</b>	<b>59</b>
			<b>MONTHS</b>	<b>MONTHS</b>
		<b>NON-RECURRING CHARGE</b>		<b>60 TO 84 MONTHS</b>
1 - 20 station lines	\$47.50	\$20.00	\$18.00	\$15.00
21 - 50 station lines	47.50	16.93	14.04	12.60
51 station lines and over				
1 Qtr mile from CO	47.50	4.81	3.88	3.45
2 Qtr miles from CO	47.50	5.22	4.22	3.75
3 Qtr miles from CO	47.50	5.64	4.57	4.07
4 Qtr miles from CO	47.50	6.19	5.03	4.49
5 Qtr miles from CO	47.50	6.67	5.43	4.84
6 Qtr miles from CO	47.50	7.18	5.85	5.22
7 Qtr miles from CO	47.50	7.82	6.39	5.71
8 Qtr miles from CO	47.50	8.33	6.81	6.09
9 Qtr miles from CO	47.50	9.15	7.49	6.70
10 Qtr miles from CO	47.50	10.80	8.87	7.94
11 Qtr miles from CO	47.50	11.53	9.48	8.49
12 Qtr miles from CO	47.50	13.87	11.42	10.24
13 Qtr miles from CO	47.50	15.73	12.98	11.64
14 Qtr miles from CO	47.50	16.66	13.59	12.19
15 Qtr miles from CO	47.50	17.64	14.57	13.07
16 Qtr miles from CO	47.50	20.33	16.81	15.09
17 Qtr miles from CO	47.50	21.22	17.56	15.76
18 Qtr miles from CO	47.50	21.97	18.18	16.32
19 Qtr miles from CO	47.50	22.65	18.75	16.83
20 Qtr miles from CO	47.50	26.50	21.95	19.72

[1] In addition, the End User Common Line Charge applies to each Common Line facility.

[2] Also apply rates and charges for Network Access Registers as found in 5.3.6, preceding.

[3] Available only with a DMS-100 Central Office. Requires the Optional Feature Message Waiting Visual as found elsewhere.

**NOTICE**  
**THE INFORMATION CONTAINED IN THIS DOCUMENT IS SUBJECT TO CHANGE.**



**Qwest Corporation**  
**Exchange and Network**  
**Services Catalog No. 1**

**SECTION 109**  
Page 82  
Release 1  
Effective: 8-1-2005

**SOUTHERN IDAHO**  
Issued: 7-1-2005

**109. OBSOLETE CENTRAL OFFICE SERVICES**

**109.1 DIAL SWITCHING SYSTEMS**

**109.1.16 CENTREX PLUS SERVICE**

D.3. (Cont'd)

		USOC
• Month-to-Month, non-blocked, each[1,2]		
- Flat main station line		R4N
- Flat extension station line		R5G
- DMS-100 main station line, with visual message waiting[3]		RQ9
	NONRECURRING CHARGE	MONTHLY RATE
1 - 20 station lines	\$47.50	\$20.00
21 - 50 station lines	47.50	20.00
51 station lines and over	47.50	20.00

[1] In addition, the End User Common Line Charge applies to each Common Line facility.

[2] In addition, Rates and Charges for usage found following will apply.

[3] Available only from a DMS-100 Central Office. Requires the Optional Feature Message Waiting Visual as found elsewhere.

**NOTICE**  
**THE INFORMATION CONTAINED IN THIS DOCUMENT IS SUBJECT TO CHANGE.**

**Qwest Corporation**  
**Exchange and Network**  
**Services Catalog No. 1**

**SECTION 109**  
Page 83  
Release 1

**SOUTHERN IDAHO**  
Issued: 7-1-2005

Effective: 8-1-2005

**109. OBSOLETE CENTRAL OFFICE SERVICES**

**109.1 DIAL SWITCHING SYSTEMS**

**109.1.16 CENTREX PLUS SERVICE**

D.3. (Cont'd)

**USOC**

- Rate stabilized non-blocked, each[1,2]
  - Flat main station line
  - Flat extension station line
  - DMS-100 flat main station line with visual message waiting[3]

R4H

R5S

RQ6

	<b>NON- RECURRING CHARGE</b>	<b>12 TO 35 MONTHS</b>	<b>36 TO 59 MONTHS</b>	<b>60 TO 84 MONTHS</b>
1 - 20 station lines	\$47.50	\$20.00	\$18.00	\$15.00
21 - 50 station lines	47.50	16.93	14.04	12.60
51 station lines and over				
1 Qtr mile from CO	47.50	4.81	3.88	3.45
2 Qtr miles from CO	47.50	5.22	4.22	3.75
3 Qtr miles from CO	47.50	5.64	4.57	4.07
4 Qtr miles from CO	47.50	6.19	5.03	4.49
5 Qtr miles from CO	47.50	6.67	5.43	4.84
6 Qtr miles from CO	47.50	7.18	5.85	5.22
7 Qtr miles from CO	47.50	7.82	6.39	5.71
8 Qtr miles from CO	47.50	8.33	6.81	6.09
9 Qtr miles from CO	47.50	9.15	7.49	6.70
10 Qtr miles from CO	47.50	10.80	8.87	7.94
11 Qtr miles from CO	47.50	11.53	9.48	8.49
12 Qtr miles from CO	47.50	13.87	11.42	10.24
13 Qtr miles from CO	47.50	15.73	12.98	11.64
14 Qtr miles from CO	47.50	16.66	13.59	12.19
15 Qtr miles from CO	47.50	17.64	14.57	13.07
16 Qtr miles from CO	47.50	20.33	16.81	15.09
17 Qtr miles from CO	47.50	21.22	17.56	15.76
18 Qtr miles from CO	47.50	21.97	18.18	16.32
19 Qtr miles from CO	47.50	22.65	18.75	16.83
20 Qtr miles from CO	47.50	26.50	21.95	19.72

[1] In addition, the End User Common Line Charge applies to each Common Line facility.

[2] In addition, Rates and Charges for usage found following will apply.

[3] Available only from a DMS-100 Central Office. Requires the Optional Feature Message Waiting Visual as found elsewhere.

**NOTICE**  
**THE INFORMATION CONTAINED IN THIS DOCUMENT IS SUBJECT TO CHANGE.**

**Qwest Corporation**  
**Exchange and Network**  
**Services Catalog No. 1**

**SECTION 109**  
Page 84  
Release 1  
Effective: 8-1-2005

**SOUTHERN IDAHO**  
Issued: 7-1-2005

**109. OBSOLETE CENTRAL OFFICE SERVICES**

**109.1 DIAL SWITCHING SYSTEMS**

**109.1.16 CENTREX PLUS SERVICE**

D.3. (Cont'd)

**USOC**

- Rate stabilized, non-blocked, each[1,2]
  - Flat main station line
  - Flat extension station line
  - DMS-100 flat main station line with visual message waiting[3]

R4H

R5S

RQ6

	<b>NON- RECURRING CHARGE</b>	<b>12 TO 35 MONTHS</b>	<b>36 TO 59 MONTHS</b>	<b>60 TO 84 MONTHS</b>
51 station lines and over				
21 Qtr miles from CO	\$47.50	\$26.79	\$22.19	\$19.93
22 Qtr miles from CO	47.50	27.07	22.43	20.14
23 Qtr miles from CO	47.50	27.35	22.66	20.35
24 Qtr miles from CO	47.50	27.63	22.89	20.56
25 Qtr miles from CO	47.50	27.91	23.13	20.77
26 Qtr miles from CO	47.50	28.19	23.36	20.98
27 Qtr miles from CO	47.50	28.47	23.59	21.19
28 Qtr miles from CO	47.50	28.75	23.83	21.40
29 Qtr miles from CO	47.50	29.03	24.06	21.61
30 Qtr miles from CO	47.50	29.31	24.29	21.92
31 Qtr miles from CO	47.50	29.59	24.53	22.03
32 Qtr miles from CO	47.50	29.87	24.76	22.24
33 Qtr miles from CO	47.50	30.15	24.99	22.45
34 Qtr miles from CO	47.50	30.43	25.23	22.66
35 Qtr miles from CO	47.50	30.71	25.46	22.87
36 Qtr miles from CO	47.50	30.99	25.69	22.08
37 Qtr miles from CO	47.50	31.27	25.93	23.29
38 Qtr miles from CO	47.50	31.55	26.16	23.50
39 Qtr miles from CO	47.50	31.83	26.39	23.71
40 Qtr miles from CO	47.50	32.05	26.58	23.88

[1] In addition, the End User Common Line Charge applies to each Common Line facility.

[2] In addition, Rates and Charges for usage found following will apply.

[3] Available only from a DMS-100 Central Office. Requires the Optional Feature Message Waiting Visual as found elsewhere.

**NOTICE**  
**THE INFORMATION CONTAINED IN THIS DOCUMENT IS SUBJECT TO CHANGE.**

**Qwest Corporation**  
**Exchange and Network**  
**Services Catalog No. 1**

**SECTION 109**  
Page 85  
Release 1

**SOUTHERN IDAHO**  
Issued: 7-1-2005

Effective: 8-1-2005

**109. OBSOLETE CENTRAL OFFICE SERVICES**

**109.1 DIAL SWITCHING SYSTEMS**

**109.1.16 CENTREX PLUS SERVICE**

D.3. (Cont'd)

	<b>USOC</b>
	<b>CUD</b>
	<b>MONTHLY RATE</b>
<ul style="list-style-type: none"><li>Usage charges for flat main station line, extension station line, non-blocked, each[1,2]</li></ul>	
1 - 20 station lines	\$28.11
21 - 50 station lines	26.11
51 station lines and over	4.17

[1] In addition, the End User Common Line Charge applies to each Common Line Facility.

[2] In addition, rates and charges for Month-to-Month flat station line non-blocked or Rate Stabilized flat station line non-blocked apply.

**NOTICE**  
**THE INFORMATION CONTAINED IN THIS DOCUMENT IS SUBJECT TO CHANGE.**

**Qwest Corporation**  
**Exchange and Network**  
**Services Catalog No. 1**

**SECTION 109**  
Page 86  
Release 1  
Effective: 8-1-2005

**SOUTHERN IDAHO**  
Issued: 7-1-2005

**109. OBSOLETE CENTRAL OFFICE SERVICES**

**109.1 DIAL SWITCHING SYSTEMS**

**109.1.16 CENTREX PLUS SERVICE**

D. Rates and Charges - Common Switching Elements (Cont'd)

	USOC	NONRECURRING CHARGE	MONTHLY RATE
4. Dormitory Station Line, each			
• Month-to-Month flat station line, blocked, each	PEJ	[1]	[1]
• Month-to-Month flat station line, non-blocked, each	PSH	[1]	[1]
• Rate stabilized flat station line, blocked, each	PEV	[1]	[1]
• Rate stabilized flat station line, non-blocked, each	PSX	[1]	[1]

5. Nonrecurring Charge - Optional Service Features and Miscellaneous Facility Arrangements

Nonrecurring Service and Equipment Charges apply per USOC (unless specified otherwise), per customer request to establish or change one or more optional features as follows:

	NONRECURRING CHARGE
• Established with the initial installation of the system access line	-
• Established subsequent to the initial installation of the access line	\$6.50
• Feature change when other service and equipment charges do not apply	6.50

[1] Same Rates and Charges as Centrex Plus Common Line Facilities.

**NOTICE**  
**THE INFORMATION CONTAINED IN THIS DOCUMENT IS SUBJECT TO CHANGE.**

**Qwest Corporation**  
**Exchange and Network**  
**Services Catalog No. 1**

**SECTION 109**  
Page 87  
Release 1

**SOUTHERN IDAHO**  
Issued: 7-1-2005

Effective: 8-1-2005

**109. OBSOLETE CENTRAL OFFICE SERVICES**

**109.1 DIAL SWITCHING SYSTEMS**

**109.1.16 CENTREX PLUS SERVICE**

D. Rates and Charges - Common Switching Elements (Cont'd)

6. Miscellaneous Facility Arrangements[1]

Provides for termination of special facilities into the system.

	USOC	NONRECURRING CHARGE	MONTHLY RATE
• Voice Grade Circuit, each			
- Per Group	FACPG	\$156.00	—
- Each Facility In Group,	FAC	19.00	\$10.50
• FX/FCO Circuit			
- Per Trunk Group	FANPG	130.00	—
- Each Facility In Group,	FAN	20.00	10.50
• WATS (outgoing), each	FAO	30.00	0.50
• 800 Service Circuit, each terminated to main station line[2]	FA8	30.00	0.50
• Miscellaneous Trunk Termination, Dial Dictation			
- Per Trunk Group, each	DK7PG	156.00	—
- Each Facility In Group	DK7	19.00	10.50

[1] Where a Centrex Plus main station line is extended as a Voice Grade Circuit to another switching system, the rates and charges specified for a Centrex Plus main station line apply in addition to the rates and charges specified for Centrex Plus Voice Grade circuit termination arrangement.

[2] In the event an incoming 800 service call is transferred outside the system, transmission performance cannot be guaranteed.

**NOTICE**  
**THE INFORMATION CONTAINED IN THIS DOCUMENT IS SUBJECT TO CHANGE.**

## **109. OBSOLETE CENTRAL OFFICE SERVICES**

### **109.1 DIAL SWITCHING SYSTEMS**

#### **109.1.16 CENTREX PLUS SERVICE**

##### **D. Rates and Charges - Common Switching Elements (Cont'd)**

###### **7. Digital Facility Interface**

###### **a. Description**

This termination provides a digital interface for a high capacity (1.544 Mbps) facility which terminates to a customer's central office based switching system. This service provides for the connectivity of 24 circuits within the Centrex Plus system.

###### **b. Regulations**

The rates and charges for the Digital Facility Interface are in addition to the rates and charges applicable for the appropriate high capacity facility. All current rules and regulations, including Federal regulations apply to the application of the high capacity facility.[1]

Digital Facility Interface will only be offered to Centrex Plus customers, and will only provide for tie lines in a non-tandem configuration.

[1] The High Capacity facility as found elsewhere should be rated as if it terminates to an end user's premises. The Centrex Plus in this case is the end user's premises.

**Qwest Corporation**  
**Exchange and Network**  
**Services Catalog No. 1**

**SECTION 109**  
Page 89  
Release 1  
Effective: 8-1-2005

**SOUTHERN IDAHO**  
Issued: 7-1-2005

**109. OBSOLETE CENTRAL OFFICE SERVICES**

**109.1 DIAL SWITCHING SYSTEMS**

**109.1.16 CENTREX PLUS SERVICE**

D. Rates and Charges - Common Switching Elements (Cont'd)

	USOC	NON-RECURRING CHARGE[1]	INSTALLATION CHARGE[1]	MONTHLY RATE
• Common Equipment[2]				
- Per digital interface unit, per 1.544Mbps facility	D1E1X	\$255.00	\$540.00	\$180.00
• Circuit Connections[2]				
- Centrex Plus to Centrex Plus, per circuit	M5P	8.50	12.00	10.00
- Centrex Plus to PBX/Key, per circuit				
- Blocked Centrex Plus	M62	8.50	12.00	8.00
- Non-blocked Centrex Plus	EJ9	8.50	12.00	25.00
- Centrex Plus Direct Inward Dialed numbers, per number[3,4]	CNY	-	1.00	0.15
- Centrex Plus to Interexchange Carrier, per circuit	M63	8.50	12.00	10.00

[1] Applies on initial and subsequent activity.

[2] For Centrex Plus to Centrex Plus connections two Digital Facility Interfaces will be required, one at each end.

[3] Blocked Centrex Plus Service - requires the use of a Network Access Register and Centrex Plus station line for each M62, circuit connection.

[4] Non-blocked Centrex Plus Service - requires the use of Centrex Plus usage, CUD and Centrex Plus station line for each EJ9, circuit connection.

**NOTICE**  
**THE INFORMATION CONTAINED IN THIS DOCUMENT IS SUBJECT TO CHANGE.**

## **109. OBSOLETE CENTRAL OFFICE SERVICES**

### **109.1 DIAL SWITCHING SYSTEMS**

#### **109.1.16 CENTREX PLUS SERVICE (Cont'd)**

##### E. Standard Service Features - Description

###### Audible Message Waiting

When a Centrex Plus user goes off hook a stutter dial tone is provided to indicate a message is waiting.

###### Automatic Callback

Provides an arrangement that permits a line user, when attempting an intercom call to a busy line, to be automatically connected to that line when both the called and calling lines are subsequently idle.

###### Call Forwarding Busy Line

Provides for forwarding of incoming calls to a preselected telephone number, when the called station is busy.

###### Call Forwarding Don't Answer

Provides for forwarding of incoming calls to a preselected telephone number, when the called station does not answer after a predetermined number of ringing cycles.

###### Call Forwarding-Variable

Allows a user to automatically forward incoming calls to any other number.

###### Call Forwarding of Call Waiting Calls

Allows users with both the Call Waiting and Call Forward Don't Answer features to have calls directed to a predetermined destination.

## **109. OBSOLETE CENTRAL OFFICE SERVICES**

### **109.1 DIAL SWITCHING SYSTEMS**

#### **109.1.16 CENTREX PLUS SERVICE**

##### E. Standard Service Features – Description (Cont'd)

##### Call Hold

Allows a station user to hold any call in progress, by dialing a code.

##### Call Park[1]

Allows a user to hold or "Park" a call by dialing a code that can be retrieved from any station by dialing another code.

##### Call Pick-Up

Enables a station user to answer calls directed to other specified stations by dialing a special code.

##### Call Waiting

Dial Originating - Provides the ability for the originating station to invoke call waiting tone on selected calls by dialing the dial call waiting access code followed by the extension number of the station to be call waited.

##### Call Waiting - Originating

Allows a calling station to direct a call waiting tone toward a busy called station within the same system.

##### Call Waiting - Terminating

Allows for a Centrex Plus station user who is engaged in a telephone conversation to be alerted via an audible tone that a call is waiting.

[1] Available only from a DMS-100 Central Office.

## **109. OBSOLETE CENTRAL OFFICE SERVICES**

### **109.1 DIAL SWITCHING SYSTEMS**

#### **109.1.16 CENTREX PLUS SERVICE**

##### E. Standard Service Features - Description (Cont'd)

##### Cancel Call Waiting

Allows a user with Call Waiting Terminating to inhibit the application of Call Waiting Tone for the duration of one call by dialing a code.

##### Conference Calling

Allows a station user to establish conference connections without the aid of an attendant.

##### Data Call Protection

Provides a no double connect option to the line, protecting data calls from interruption.

##### Direct Inward/Outward Dialing

Allows station users to place or receive calls bypassing the attendant.

##### Distinctive Ringing/Distinctive Call Waiting Tone

Enables a station user to determine the source of an incoming call.

##### Executive Busy Override[1]

Allows a station user to gain access to a busy station.

##### Hunting

Allows incoming calls to hunt to the next number in a hunting sequence if the number is busy. Various types of hunting are available such as Series Completion, Multiline Hunt, Preferential Hunt and Circular Hunt.

[1] Available only from a DMS-100 Central Office.

## **109. OBSOLETE CENTRAL OFFICE SERVICES**

### **109.1 DIAL SWITCHING SYSTEMS**

#### **109.1.16 CENTREX PLUS SERVICE**

##### E. Standard Service Features - Description (Cont'd)

##### Individual Line Billing

Toll calls are billed directly against the line placing the call.

##### Intercept

Disconnected or unassigned lines can be forwarded to a common announcement or to the customer Centralized Answering Position.

##### Intrasystem Calling

A user can dial other lines on the system on a two digit to five digit basis depending on the number of lines within the system.

##### Last Number Redial[1]

Allows users to redial the last number called.

##### Line Restrictions

Various line restrictions are available such as toll facility and various originating and terminating restrictions.

##### Make Set Busy[1]

Allows directory number appearances and call terminations such as Call Waiting Calls, and Executive Busy override to be made busy to incoming calls.

##### Network Speed Call[1]

Allows each station user access to a single list of 1,000 preprogrammed numbers which can be shared by all stations in the system (not customer changeable).

[1] Available only from a DMS-100 Central Office.

## **109. OBSOLETE CENTRAL OFFICE SERVICES**

### **109.1 DIAL SWITCHING SYSTEMS**

#### **109.1.16 CENTREX PLUS SERVICE**

##### E. Standard Service Features - Description (Cont'd)

##### Outgoing Trunk Queuing

Provides efficient usage of private facilities by queuing individual station calls and providing a maximum time limit for a call to remain on queue before possible overflow to the direct distance dialing network.

##### Speed Calling

Allows a user to place calls to a list of frequently dialed numbers by dialing a speed calling code.

##### Three-Way Calling/Consultation Hold/Call Transfer

User can connect a third line to an established connection. A user can depress the switchhook and consult in private with a third party and return to the original call by using only one line. A user of a line can transfer any established call to another line within or outside the Centrex Plus System.

##### Touch-Tone

Allows for customer provided equipment to place calls on the Centrex Plus system.

##### Trunk Answer Any Station (Night Service)

Allows any line in the Night Answer Group to be picked up by any other line of the system.

[1] Available only from a DMS-100 Central Office.

**Qwest Corporation**  
**Exchange and Network**  
**Services Catalog No. 1**

**SECTION 109**  
Page 95  
Release 1  
Effective: 8-1-2005

**SOUTHERN IDAHO**  
Issued: 7-1-2005

**109. OBSOLETE CENTRAL OFFICE SERVICES**

**109.1 DIAL SWITCHING SYSTEMS**

**109.1.16 CENTREX PLUS SERVICE (Cont'd)**

F. Rates and Charges - Optional Service Features

1. Account Codes

Allows a user to dial an account code for bill back purposes before placing a call.

	<b>USOC</b>	<b>INSTALLATION CHARGE</b>	<b>MONTHLY RATE</b>
• Per system	AZ8PS	\$175.00	\$50.00

2. Attendant Access Line Service

Allows a Centrex Plus Attendant Line to receive dial "zero" calls.

	<b>USOC</b>	<b>INSTALLATION CHARGE</b>	<b>MONTHLY RATE</b>
• Per station line	DZR	—	\$8.00

**NOTICE**  
**THE INFORMATION CONTAINED IN THIS DOCUMENT IS SUBJECT TO CHANGE.**

**Qwest Corporation**  
**Exchange and Network**  
**Services Catalog No. 1**

**SECTION 109**  
Page 96  
Release 1  
Effective: 8-1-2005

**SOUTHERN IDAHO**  
Issued: 7-1-2005

**109. OBSOLETE CENTRAL OFFICE SERVICES**

**109.1 DIAL SWITCHING SYSTEMS**

**109.1.16 CENTREX PLUS SERVICE**

F. Rates and Charges - Optional Service Features (Cont'd)

3. Attendant Set Interface[1,2]

Enables a group of DMS-100 station lines to be served by a single attendant position which includes attendant features.

	<b>USOC</b>	<b>INSTALLATION CHARGE</b>	<b>MONTHLY RATE</b>
• Per interface	A1J	\$430.00	\$150.00

4. Authorization Codes

Requires a user to dial an authorization code before using system facilities.

	<b>USOC</b>	<b>INSTALLATION CHARGE</b>	<b>MONTHLY RATE</b>
• Per system	AFYPS	\$170.00	\$50.00

[1] Each attendant set interface requires a main station line.

[2] Available from a DMS-100 central office only.

**NOTICE**  
**THE INFORMATION CONTAINED IN THIS DOCUMENT IS SUBJECT TO CHANGE.**

## **109. OBSOLETE CENTRAL OFFICE SERVICES**

### **109.1 DIAL SWITCHING SYSTEMS**

#### **109.1.16 CENTREX PLUS SERVICE**

##### F. Rates and Charges - Optional Service Features (Cont'd)

##### 5. Automatic Route Selection (ARS)

###### a. Description

ARS is an optional feature, available where facilities permit that allows station users, by dialing a preselected code, to automatically select the preferred route subscribed for by a customer, for network calls. Alternate routing to other facilities subscribed for by the customer, is also provided. This arrangement is available for use with FX, WATS and MTS Network.

ARS is accessed by dialing a single code (1, 2, or 3 digits) which automatically selects the appropriate route to complete the call. If all facilities in the initial route selected are busy, the call will advance to other routes in the selected pattern. Patterns may consist of up to (4) a private routes. If no route is available, the call will route to the selected long distance carrier or overflow tone at the customer's option.

The routing may be based on a number plan area (NPA) or specific CO codes within an NPA as designated by the customer.

###### b. Regulations

All rates and charges specified for ARS are in addition to the rates and charges for the associated facilities.

Preferred routes and alternate routing patterns will be specified by the customer.

The number of patterns required by a customer is governed by the type and variety of facilities to which the customer subscribes. The maximum number of patterns is 64.

A pattern may have either the selected carrier or overflow tone as a final route. Dial 9 may be used as an access code only if the patterns accessed have the selected carrier as a final route.

A route cannot be used more than once in the same pattern.

The customer is responsible for notifying the Company whenever any additions or changes of routes or patterns are required.

## **109. OBSOLETE CENTRAL OFFICE SERVICES**

### **109.1 DIAL SWITCHING SYSTEMS**

#### **109.1.16 CENTREX PLUS SERVICE**

##### F.5. (Cont'd)

##### c. Explanation of Terms

###### Route

A route is a group of one or more facilities of the same type used to complete 7 or 10 digit calls between the same points, (e.g., 1 FX or 3 WATS Band 1 lines, or 2 WATS Band 5 lines, etc.). A WATS Band 1 and a WATS Band 5 are considered to be two routes.

###### Route Selection

The automatic selection of the preferred route as predetermined by the customer, upon dialing of an access code by the station user.

###### Pattern

A group of routes arranged to be selected in a sequence specified by the customer.

###### Expensive Route Warning Tone

Provides a warning tone to indicate the selection of an expensive route.

**Qwest Corporation**  
**Exchange and Network**  
**Services Catalog No. 1**

**SECTION 109**  
Page 99  
Release 1  
Effective: 8-1-2005

**SOUTHERN IDAHO**  
Issued: 7-1-2005

**109. OBSOLETE CENTRAL OFFICE SERVICES**

**109.1 DIAL SWITCHING SYSTEMS**

**109.1.16 CENTREX PLUS SERVICE**

F.5. (Cont'd)

d. Rates and Charges

	<b>USOC</b>	<b>INSTALLATION CHARGE</b>	<b>MONTHLY RATE</b>
• Automatic Route Selection[1]			
- Common Equipment, per customer group	F5GPG	\$1,455.00	\$100.00
• Changes and rearrangements of Patterns and Routes[2]			
- Per Pattern, each	READO	100.00	—
- Per Route, each	REAGP	72.00	—
• Expensive Route Warning Tone			
- Per System	AQWPS	60.00	—

[1] Each WATS Band is treated as a separate route.

[2] Where a toll restricted station line accesses a pattern whose final route is the MTS, overflow to MTS will not occur.

**NOTICE**  
**THE INFORMATION CONTAINED IN THIS DOCUMENT IS SUBJECT TO CHANGE.**

**Qwest Corporation**  
**Exchange and Network**  
**Services Catalog No. 1**

**SECTION 109**  
Page 100  
Release 1

**SOUTHERN IDAHO**  
Issued: 7-1-2005

Effective: 8-1-2005

**109. OBSOLETE CENTRAL OFFICE SERVICES**

**109.1 DIAL SWITCHING SYSTEMS**

**109.1.16 CENTREX PLUS SERVICE**

F. Rates and Charges - Optional Service Features (Cont'd)

6. Call Forwarding via Private Facilities

a. Description

A main station line equipped with the Call Forwarding via Private Facilities feature provides for the automatic routing of incoming calls to a specific private facility which is terminated in that main station line user's system. As used herein, the term "private facility" applies to Enhanced Private Switching Communication System (EPSCS), Electronic Tandem Switching (ETS), Wide Area Telephone Service (WATS), Foreign Exchange (FX), and Voice Grade Circuits arranged for senderized operation, and the local and toll message network.

b. Regulations

Incoming local and toll message network and INWATS calls to main station lines arranged for Call Forwarding via Private Facilities routing are subject to the appropriate charges for such calls and a common recorded announcement is furnished to inform the caller that the call is being forwarded.

Calls forwarded to the local and toll message network and WATS are subject to the appropriate charges for such calls.

c. Rates and Charges

	<b>USOC</b>	<b>INSTALLATION CHARGE</b>	<b>MONTHLY RATE</b>
• Common equipment, per system	PF3PS	\$850.00	—
• Per main station line	PFY	5.00[1]	\$0.10

[1] Installation Charge applies for subsequent installation only.

## **109. OBSOLETE CENTRAL OFFICE SERVICES**

### **109.1 DIAL SWITCHING SYSTEMS**

#### **109.1.16 CENTREX PLUS SERVICE**

##### F. Rates and Charges - Optional Service Features (Cont'd)

##### 7. Centrex Management System (CMS)

###### a. Description

CMS is a computer software program that provides the customer access to their data base for the purpose of general data base inquiry, move, add, delete and change features. In addition CMS enables the customer to move and change station lines and generate Basic Management Reports.

CMS is generally available in 1AESS, 5ESS, and DMS100 central offices. CMS is activated on a per Centrex central office basis. When CMS is installed, a customer specific database is created. Each database is assigned a distinct customer identification name (Customer ID). This ID corresponds to the customer's specific Centrex Plus common block system. However, customers may request a single ID for multiple common block systems within the same central office.

###### b. Feature List

The following standard features are provided to all CMS customers.

###### (1) Standard Features

###### Basic Management Reports

The ability to generate management reports regarding the customer's system. These reports vary by switch type and may change with software updates. The report function gathers current data only. CMS does not keep a past history log.

###### Database Synchronization

The ability to update the CMS database station line information to agree with the information in the switch.

**Qwest Corporation**  
**Exchange and Network**  
**Services Catalog No. 1**

**SECTION 109**  
Page 102  
Release 1

**SOUTHERN IDAHO**  
Issued: 7-1-2005

Effective: 8-1-2005

**109. OBSOLETE CENTRAL OFFICE SERVICES**

**109.1 DIAL SWITCHING SYSTEMS**

**109.1.16 CENTREX PLUS SERVICE**

F.7.b.(1) (Cont'd)

Feature Move, Add, and Change

The ability to perform station number changes and to move, add, or change most features on the system from customer-provided equipment located on the customer's premises.

Transactions will either be put in a batch or priority transmission status. A batch transmission constitutes transactions scheduled for the current day or some future date. Priority functionality is described in standard features.

CMS will process batch change requests, which have accumulated throughout the day during off-peak load hours, overnight, or at a customer-specified future date.

Change request transactions can be created for station line numbers, authorization codes, automatic route selection, packet telephone numbers, and telephone number swaps. Depending on the type of change request, CMS will display different screens. CMS customers may manipulate most features and options displayed on a given screen. When the customer submits the changes, a pending record is created and CMS counts this change request as one single transaction. All change request transactions are cumulative; CMS tallies all daily transactions and will not process any transactions that exceed batch or priority parameter limits.

The number of batch change request transactions that a customer can enter per effective date will be determined by the number of Centrex lines per database. Refer to the following table. Up to 60 pairs of telephone numbers can be swapped per day. These changes take place overnight or at some future date as determined by the customer.

<b>NUMBER OF LINES PER DATABASE</b>	<b>NUMBER OF BATCH</b>	<b>NUMBER OF BATCH DBSYNCHS</b>
1 - 2000	100	10
2001 - 4000	110	15
4001 - 6000	120	20
6001 - 8000	130	25
8001 - 10000	140	30
10001+	150	35

**NOTICE**  
**THE INFORMATION CONTAINED IN THIS DOCUMENT IS SUBJECT TO CHANGE.**

**Qwest Corporation**  
**Exchange and Network**  
**Services Catalog No. 1**

**SECTION 109**  
Page 103  
Release 1

**SOUTHERN IDAHO**  
Issued: 7-1-2005

Effective: 8-1-2005

---

**109. OBSOLETE CENTRAL OFFICE SERVICES**

**109.1 DIAL SWITCHING SYSTEMS**

**109.1.16 CENTREX PLUS SERVICE**

F.7.b.(1) (Cont'd)

Bulk Change

Allows customers to request the same feature change to be applied to multiple lines simultaneously.

Inquiry

The ability to access a data base to review the status of station lines and features on the customer's system.

Network Manipulation

Dependent on central office switching technology, customers can manage a range of network features:

- 1AESS - can change the Facilities Restriction Level (FRL) on Electronic Tandem Service (ETS) station numbers.
- 5ESS - Automatic Route Selection (ARS) Active Pattern Group modifications, as well as Time of Day Routing, FRL, and Expensive Route Warning Tone.
- DMS100 - Network Class of Service (NCOS) modifications, as well as Time of Day Routing and Expensive Route Warning Tone.

Telephone Number Swaps

The ability to exchange all service option assignments and features from one station line to another.

**NOTICE**  
**THE INFORMATION CONTAINED IN THIS DOCUMENT IS SUBJECT TO CHANGE.**

**Qwest Corporation**  
**Exchange and Network**  
**Services Catalog No. 1**

**SECTION 109**  
Page 104  
Release 1

**SOUTHERN IDAHO**  
Issued: 7-1-2005

Effective: 8-1-2005

**109. OBSOLETE CENTRAL OFFICE SERVICES**

**109.1 DIAL SWITCHING SYSTEMS**

**109.1.16 CENTREX PLUS SERVICE**

F.7.b.(1) (Cont'd)

Priority Service

Allows customers to request priority transmission of transactions which are then processed in the serving central office. This may be defined as same-day service. The number of priority change transactions a customer may enter per day will be determined by the number of Centrex lines per database. Refer to the following table. Up to 5 pairs of telephone numbers can be swapped per day.

The Company does not guarantee specific time frames for completion of priority transactions.

<b>NUMBER OF LINES PER DATABASE</b>	<b>NUMBER OF BATCH</b>	<b>NUMBER OF BATCH DBSYNCHS</b>
1 - 2000	20	10
2001 - 4000	30	15
4001 - 6000	40	20
6001 - 8000	50	25
8001 - 10000	60	30
10001+	70	35

**NOTICE**  
**THE INFORMATION CONTAINED IN THIS DOCUMENT IS SUBJECT TO CHANGE.**

---

## **109. OBSOLETE CENTRAL OFFICE SERVICES**

### **109.1 DIAL SWITCHING SYSTEMS**

#### **109.1.16 CENTREX PLUS SERVICE**

##### F.7.b. (Cont'd)

#### (2) Optional Features

##### Custom Reports

Customers can request customized report formats to be created for various aspects of their system. Once created, the custom report is stored in the customer's data base and can be utilized at any time.

##### System Partitioning

The Company, upon the customer's request, can partition the Centrex customer group into separate databases representing different customer groups. Each partition is assigned a distinct customer identification name (Customer ID), and can be arranged to be accessible only to certain users designated by the customer.

##### Packet Control Capability

Gives Centrex Plus customers with ISDN, the ability to manage their packet control features. Customers that subscribe to the Packet Control Capability can verify current and pending packet options, add, delete or change packet options and run reports regarding packet assignments.

**Qwest Corporation**  
**Exchange and Network**  
**Services Catalog No. 1**

**SECTION 109**  
Page 106  
Release 1

**SOUTHERN IDAHO**  
Issued: 7-1-2005

Effective: 8-1-2005

**109. OBSOLETE CENTRAL OFFICE SERVICES**

**109.1 DIAL SWITCHING SYSTEMS**

**109.1.16 CENTREX PLUS SERVICE**

F.7. (Cont'd)

c. Terms and Conditions

The Company will furnish and maintain CMS software for use by the customer. CMS requires special central office equipment and is not provided in all central offices. The Company will offer CMS where there is available facilities and central office equipment as determined by the Company.

The customer must obtain and maintain a compatible computer terminal for use with CMS. The computer terminal will not be furnished by the Company. A business exchange access line or Centrex Plus main station line is also required, which is in addition to the rates and charges for CMS.

CMS is available for access by the customer 23 hours a day, seven days a week. A Company technician will be available Monday-Friday 7:00-5:00 to assist CMS customers with their problems and questions.

The Company reserves all rights to take the CMS computer down for software updates or maintenance as required. When possible, software updates will be done during off-peak hours and customers will be warned in advance. Maintenance routines will be done the third week-end of every month.

The Company does not implicitly warrant CMS from any unforeseen software or hardware problems where an entire customer database is lost. The Company will re-establish the database if lost.

All normal and emergency central office functions have priority over customer requested changes. The Company assumes no responsibility for change requests delayed by such Company functions.

The Company will provide the customer a CMS User Handbook and training at the time of initial installation. The Company reserves the right to upgrade or change CMS at anytime. Any additional customer training or documentation requirements resulting from such changes will be supplied at no charge.

**NOTICE**  
**THE INFORMATION CONTAINED IN THIS DOCUMENT IS SUBJECT TO CHANGE.**

**Qwest Corporation**  
**Exchange and Network**  
**Services Catalog No. 1**

**SECTION 109**  
Page 107  
Release 1

**SOUTHERN IDAHO**  
Issued: 7-1-2005

Effective: 8-1-2005

---

**109. OBSOLETE CENTRAL OFFICE SERVICES**

**109.1 DIAL SWITCHING SYSTEMS**

**109.1.16 CENTREX PLUS SERVICE**

F.7.c. (Cont'd)

New connects and disconnects of station lines are not permitted through CMS.

The customer assumes full responsibility for the features managed by CMS. The Company will not maintain a separate record of which features are activated on each station line.

CMS software allows the customer to move and change station numbers within their system, the customer will be responsible for labeling the Network Interface when number changes occur. All maintenance calls to the Company in which the trouble proves to be other than on the Company side of the Network Interface will result in the application of Trouble Isolation Charges, as specified in elsewhere. The Trouble Isolation Charge will not apply to lines equipped with *UNISTAR* Service.

NOTICE  
THE INFORMATION CONTAINED IN THIS DOCUMENT IS SUBJECT TO CHANGE.

**Qwest Corporation**  
**Exchange and Network**  
**Services Catalog No. 1**

**SECTION 109**  
Page 108  
Release 1

**SOUTHERN IDAHO**  
Issued: 7-1-2005

Effective: 8-1-2005

**109. OBSOLETE CENTRAL OFFICE SERVICES**

**109.1 DIAL SWITCHING SYSTEMS**

**109.1.16 CENTREX PLUS SERVICE**

F.7. (Cont'd)

d. Rates and Charges

All nonrecurring charges for CMS will be applied on a per common block system basis. Nonrecurring Charges, found elsewhere in this Services Catalog, do not apply when the customer moves, activates, deactivates, changes features and moves or changes lines through CMS.

An initial Service Establishment Charge will be applied to the first Customer ID. A subsequent System Establishment Charge will be applied to succeeding Customer ID's providing the customer manages all CMS changes from only one central location.

Features added through CMS carry the same recurring rates, nonrecurring charges and system charges as if they were added through the conventional service order process and will be reflected on the customer's bill as such.

If CMS is disconnected, Nonrecurring Charges, as specified elsewhere in this Services Catalog, will apply per line for all changes or rearrangements to system features.

If the customer moves their Centrex Plus system from one CO to another, and station line number changes are involved, a subsequent installation charge to reestablish the CMS data base will apply.

**NOTICE**  
**THE INFORMATION CONTAINED IN THIS DOCUMENT IS SUBJECT TO CHANGE.**

**Qwest Corporation**  
**Exchange and Network**  
**Services Catalog No. 1**

**SECTION 109**  
Page 109  
Release 1

**SOUTHERN IDAHO**  
Issued: 7-1-2005

Effective: 8-1-2005

**109. OBSOLETE CENTRAL OFFICE SERVICES**

**109.1 DIAL SWITCHING SYSTEMS**

**109.1.16 CENTREX PLUS SERVICE**

F.7.d. (Cont'd)

	<b>USOC</b>	<b>NONRECURRING CHARGE</b>
• System Establishment		
- Initial Installation	MB5XX	\$1,000.00
- Subsequent installation for an associated system	CPVWO	500.00
• Optional Features		
- Custom Reports	RCVXX	[1]
- System Partitioning	PD8XX	500.00
- Packet Control Capability	PTGPS	1,500.00

8. Direct Inward System Access (DISA)[2]

Allows a customer to dial access to the system from an outside line and receive access to features and facilities of that system.

	<b>USOC</b>	<b>INSTALLATION CHARGE</b>	<b>MONTHLY RATE</b>
• Per access code	3DQ	\$27.00	\$1.00
• Per access code changed	READA	25.00	-

[1] Rates and charges will be based on an individual case basis per customer request.

[2] Available only from a DMS-100 Central Office.

**NOTICE**  
**THE INFORMATION CONTAINED IN THIS DOCUMENT IS SUBJECT TO CHANGE.**

## **109. OBSOLETE CENTRAL OFFICE SERVICES**

### **109.1 DIAL SWITCHING SYSTEMS**

#### **109.1.16 CENTREX PLUS SERVICE**

##### F. Rates and Charges - Optional Service Features (Cont'd)

###### 9. Electronic Set Service[1]

###### a. Description

Electronic Set Service permits the use of special electronic station sets with Centrex Plus Service. This service utilizes a unique line card to provide communications control for the electronic station set.

The customer-provided electronic set is a touchtone station that provides programmable keys for features and additional numbers. It is served from the central office by a main or extension station line. It has assignable keys for station line pick-ups or features. Electronic sets and adjunct modules are provided by the customer.

###### b. Regulations

Electronic Set Service will be provided only where facilities permit.

Each electronic set must be associated with a Primary Directory Number. In addition, an Electronic Set Service interface card is required.

Electronic Set Service is subject to a 1.5 mile limitation from the central office.

Electronic Set Service is only available on Centrex Plus main station lines. Main station lines with electronic sets cannot have extension stations; however, the primary directory number associated with the main station line can appear as a secondary appearance of a primary directory number on other main station lines.

[1] Available only from a DMS-100 Central Office.

**Qwest Corporation**  
**Exchange and Network**  
**Services Catalog No. 1**

**SECTION 109**  
Page 111  
Release 1

**SOUTHERN IDAHO**  
Issued: 7-1-2005

Effective: 8-1-2005

**109. OBSOLETE CENTRAL OFFICE SERVICES**

**109.1 DIAL SWITCHING SYSTEMS**

**109.1.16 CENTREX PLUS SERVICE**

F.9. (Cont'd)

c. Explanation of Terms

Multiple Appearance Directory Number (MADN)

A directory number assigned to more than one electronic station set.

Software Numbers

Software numbers are numbers which do not require an additional station line. These numbers share the facilities of the primary directory listed number. Variations of software numbers are:

- Primary Appearance

The first appearance of a software number on a key.

- Secondary Appearance

The second appearance of a software number on a key. The secondary software number can be on the same station or a different station.

- Single Appearance

A software number that appears only on one station and one key.

NOTICE  
THE INFORMATION CONTAINED IN THIS DOCUMENT IS SUBJECT TO CHANGE.

## **109. OBSOLETE CENTRAL OFFICE SERVICES**

### **109.1 DIAL SWITCHING SYSTEMS**

#### **109.1.16 CENTREX PLUS SERVICE**

F.9. (Cont'd)

d. Standard Feature Package Description

Auto Answer Back

Allows any incoming calls to the primary directory number of the set to be automatically answered after four seconds.

Automatic Dial

The automatic dial feature allows an electronic set user to call a frequently dialed number by pressing an assigned key. The user is permitted to change the number stored against the assigned key.

Automatic Line

Allows equipped station to automatically place a call to a preassigned number by going off-hook.

Call Forward Reason Display

Provides an electronic set user with the reason the intrasystem call has forwarded. Electronic set must be equipped with display.

Display Called Number

Provides user with visual feedback concerning the called number when the electronic set is equipped with appropriate alphanumeric LCD.

## **109. OBSOLETE CENTRAL OFFICE SERVICES**

### **109.1 DIAL SWITCHING SYSTEMS**

#### **109.1.16 CENTREX PLUS SERVICE**

F.9.d. (Cont'd)

##### Display Calling Number

Provides user with visual feedback concerning the intrasystem calling number when the electronic set is equipped with appropriate alphanumeric LCD.

##### Fast Transfer

Provides the capability for the electronic set user to transfer a call without first having to conference a called party.

##### Group Intercom

Provides the ability to directly terminate on a predesignated button on another electronic station set by depressing an intercom key.

##### Message Waiting Set

This feature provides a message waiting indication on an electronic set via a message waiting lamp.

##### Privacy Release

Permits a user to establish a conference call among MADN members and an outside party by pressing an assigned key or dialing a code.

##### Query Time

This feature provides the current time and date on an electronic set display.

## **109. OBSOLETE CENTRAL OFFICE SERVICES**

### **109.1 DIAL SWITCHING SYSTEMS**

#### **109.1.16 CENTREX PLUS SERVICE**

F.9. (Cont'd)

e. Standard Deluxe Feature Package Description

Business Set Call Forward Per Key

Enables each directory number assigned to be forwarded to a different directory number.

Business Set Inspect Key

Provides display equipped electronic set users with information regarding features and directory numbers that are assigned to their set as well as incoming call information on an intra-system basis only.

Executive Message Waiting

Provides multiple message waiting indications per directory number.

Group Intercom All Calls

Enables an electronic set user to simultaneously intercom and page up to 29 predefined group intercom members. Group members hear the page over their sets built in speaker.

Music on Hold - Electronic Set[1]

Provides the electronic set with access to system Music on Hold.

Originating/Terminating Line Select

Automatically selects the line when a user answers a call and automatically connects the user to an idle line on outgoing calls.

[1] Requires Music on Hold.

**Qwest Corporation**  
**Exchange and Network**  
**Services Catalog No. 1**

**SECTION 109**  
Page 115  
Release 1

**SOUTHERN IDAHO**  
Issued: 7-1-2005

Effective: 8-1-2005

---

**109. OBSOLETE CENTRAL OFFICE SERVICES**

**109.1 DIAL SWITCHING SYSTEMS**

**109.1.16 CENTREX PLUS SERVICE**

F.9. (Cont'd)

f. Optional Feature Description

Direct Station Selection/Busy Lamp Field

Adds improved answering-position functions to the electronic set by providing busy lamp status and direct station selection.

Message Center

Provides message center functionality to the electronic set. System users access the message center via dialing a code.

Station Camp-On

Allows the electronic set user to call a busy line and place the caller on hold/camp against the busy party's line until they are free.

NOTICE  
THE INFORMATION CONTAINED IN THIS DOCUMENT IS SUBJECT TO CHANGE.

**Qwest Corporation**  
**Exchange and Network**  
**Services Catalog No. 1**

**SECTION 109**  
Page 116  
Release 1

**SOUTHERN IDAHO**  
Issued: 7-1-2005

Effective: 8-1-2005

**109. OBSOLETE CENTRAL OFFICE SERVICES**

**109.1 DIAL SWITCHING SYSTEMS**

**109.1.16 CENTREX PLUS SERVICE**

F.9. (Cont'd)

g. Rates and Charges

All rates and charges specified for Electronic Set Service are in addition to the rates and charges associated for the main station line, all associated facilities and optional service features.

The Nonrecurring Charges to rearrange primary directory numbers and/or software directory numbers on Electronic Set Service is the same as to install new.

**USOC**

- Electronic set common line facilities[1]
  - Month-to-Month flat station line, blocked, each EPZ
  - Month-to-Month flat station line, non-blocked, each R63
  - Rate stabilized flat station line, blocked, each E3W
  - Rate stabilized flat station line, non-blocked, each R6V

[1] Same rates and charges as a Centrex Plus Common Line Facilities.

**NOTICE**  
**THE INFORMATION CONTAINED IN THIS DOCUMENT IS SUBJECT TO CHANGE.**

**Qwest Corporation**  
**Exchange and Network**  
**Services Catalog No. 1**

**SECTION 109**  
Page 117  
Release 1

**SOUTHERN IDAHO**  
Issued: 7-1-2005

Effective: 8-1-2005

**109. OBSOLETE CENTRAL OFFICE SERVICES**

**109.1 DIAL SWITCHING SYSTEMS**

**109.1.16 CENTREX PLUS SERVICE**

F.9.g. (Cont'd)

	<b>USOC</b>	<b>INSTALLATION CHARGE</b>	<b>MONTHLY RATE</b>
• Electronic set service interface, per main station line[1]	PP3	\$10.00	\$2.40
• Primary appearance of a software number	S03	5.00	1.00
• Subsequent appearance of a software number	S05	5.00	–
• Single appearance of a software number	SFB	5.00	1.00
• Adjunct module, per module[2]	C2TAX	15.00	4.50

[1] Includes electronic set service standard features.

[2] In addition, rates and charges specified above for primary directory number appearances and software number appearances apply.

**NOTICE**  
**THE INFORMATION CONTAINED IN THIS DOCUMENT IS SUBJECT TO CHANGE.**

**Qwest Corporation**  
**Exchange and Network**  
**Services Catalog No. 1**

**SECTION 109**  
Page 118  
Release 1

**SOUTHERN IDAHO**  
Issued: 7-1-2005

Effective: 8-1-2005

**109. OBSOLETE CENTRAL OFFICE SERVICES**

**109.1 DIAL SWITCHING SYSTEMS**

**109.1.16 CENTREX PLUS SERVICE**

F.9.g. (Cont'd)

	USOC	INSTALLATION CHARGE	MONTHLY RATE
• Standard Deluxe Feature Package			
- Business Set Call Forward per key, per Set	EATPK	\$ 15.00	-
- Business Set Inspect Key	NP6PK	15.00	-
- Executive Message Waiting	MGK	15.50	-
- Group Intercom All Calls	GCN	7.00	-
- Music on Hold - Electronic Set [1]	MHHPK	12.00	-
- Originating/Terminating Line Select	SLB	7.00	-
• Optional Features			
- Direct Station Selection/ Busy Lamp Field, per arrangement	BUD	200.00	\$5.00
- Station Camp-On, Service Establishment	SEPFb	50.00	-
- Station Camp-On, per main station line	CPK	160.00	9.00
- Message Center, per main station line	MFR	125.00	2.50

[1] Requires Optional Service Feature Music on Hold.

**Qwest Corporation**  
**Exchange and Network**  
**Services Catalog No. 1**

**SECTION 109**  
Page 119  
Release 1

**SOUTHERN IDAHO**  
Issued: 7-1-2005

Effective: 8-1-2005

**109. OBSOLETE CENTRAL OFFICE SERVICES**

**109.1 DIAL SWITCHING SYSTEMS**

**109.1.16 CENTREX PLUS SERVICE**

F. Rates and Charges - Optional Service Features (Cont'd)

10. Hot Line (Automatic Line)

Allows equipped station to automatically place a call to a preassigned number by going off-hook.

	<b>USOC</b>	<b>INSTALLATION CHARGE</b>	<b>MONTHLY RATE</b>
• Per line equipped	HLN	\$5.00	\$1.00

11. Loudspeaker Paging

Line Side allows access to Loudspeaker Paging via a Centrex Plus Station line. Trunk Side allows access to Loudspeaker Paging by dialing an access code. Attendant Access allows access to Loudspeaker Paging from the attendant console.

	<b>USOC</b>	<b>INSTALLATION CHARGE</b>	<b>MONTHLY RATE</b>
• Trunk Side, per group	PTQPG	\$200.00	\$20.15
• Attendant Access, per console	PA1PC	13.70	13.60

**NOTICE**  
**THE INFORMATION CONTAINED IN THIS DOCUMENT IS SUBJECT TO CHANGE.**

**109. OBSOLETE CENTRAL OFFICE SERVICES**

**109.1 DIAL SWITCHING SYSTEMS**

**109.1.16 CENTREX PLUS SERVICE**

F. Rates and Charges - Optional Service Features (Cont'd)

12. Message Waiting Visual[1]

Provides the ability to light a lamp on customer provided equipment by dialing a code.

	<b>USOC</b>	<b>INSTALLATION CHARGE</b>	<b>MONTHLY RATE</b>
• Per main station line	MLN	\$5.00	\$1.00

13. Multiple Position Hunt

Is a type of multiline hunting arrangement that distributes incoming calls to attendant positions according to the type of call.

	<b>USOC</b>	<b>INSTALLATION CHARGE</b>	<b>MONTHLY RATE</b>
• Per main station line	MHU	\$11.00	\$2.00

14. Remote Access[2,3]

Allows a customer user to dial access the system from an outside line and receive access to features and facilities of that system.

	<b>USOC</b>	<b>INSTALLATION CHARGE</b>	<b>MONTHLY RATE</b>
• Per access code	ROA	\$48.00	\$42.00
• Per access code changed	READA	25.00	-

[1] Available only from a DMS-100 Central Office.

[2] In the event an incoming call is transferred to a remote location, transmission performance cannot be guaranteed.

[3] Not available from a DMS-100 Central Office.

**Qwest Corporation**  
**Exchange and Network**  
**Services Catalog No. 1**

**SECTION 109**  
Page 121  
Release 1

**SOUTHERN IDAHO**  
Issued: 7-1-2005

Effective: 8-1-2005

**109. OBSOLETE CENTRAL OFFICE SERVICES**

**109.1 DIAL SWITCHING SYSTEMS**

**109.1.16 CENTREX PLUS SERVICE**

F. Rates and Charges - Optional Service Features (Cont'd)

15. Station Message Detail Recording[1]

a. Description

SMDR provides detail on calls that originate from a Centrex Plus common block system(s). Call detail may include: date, time, call duration, station line from which calls originated, called number and carrier selected. SMDR call detail is provided on originating Toll, Outward WATS, Voice Grade channels, Foreign Exchange Service and Directory Assistance calls. Local call detail also is available, requests will be on an individual case basis only.

A customer may use SMDR call detail for identifying, analyzing, and resolving internal network usage issues. The company does not represent SMDR call detail to be valid for billing purposes.

The type of call detail and the method by which it is obtained is dependent upon the type of SMDR technology deployed in the central office serving the customer. Two methods of receiving SMDR are, SMDR to Premises SMDR-P and SMDR Regional Accounting Office SMDR-RAO.

SMDR-P allows customers to obtain daily call detail on their outgoing chargeable calls. The customer's call detail records are stored by the SMDR-P equipment and delivered directly over an access line to the customer's premises. The detail is collected by a customer provided call detail recorder which is usually a customer's personal computer using call accounting software. Through the use of the call accounting package, customers are able to process the call details and generate management reports.

SMDR-RAO allows customers to receive call detail on a monthly basis via magnetic tape. The tape is offered within four categories: Miscellaneous SMDR, Large User Toll, Directory Assistance and WATS. Customers could receive up to four different tapes for their accumulated call detail. Magnetic tape records are in a standard industry-wide format called Exchange Message Record (EMR). A customer's in-house data processing equipment or outside data processor must be able to read this tape as to physical size as well as format.

[1] Customers signing a contract after April 23, 1993, will receive SMDR at rates and charges specified in the section. Customers that have RSP Arrangements prior to April 23, 1993 must sign a new RSP Arrangement to have SMDR from this Section.

**NOTICE**  
**THE INFORMATION CONTAINED IN THIS DOCUMENT IS SUBJECT TO CHANGE.**

## **109. OBSOLETE CENTRAL OFFICE SERVICES**

### **109.1 DIAL SWITCHING SYSTEMS**

#### **109.1.16 CENTREX PLUS SERVICE**

F.15. (Cont'd)

b. Terms and Conditions

The regulations specified herein are in addition to applicable Terms and Conditions specified elsewhere.

The customer is responsible for providing the necessary computer hardware and software for processing SMDR data. SMDR data delivered to customers by way of SMDR-P or SMDR-RAO is an electronic listing of call detail.

SMDR content is not represented as an image of a bill and is not a valid challenge to the accuracy of the bill.

Temporary suspension, either full or partial, of SMDR is not permitted.

The Company does not implicitly warrant SMDR from any unforeseen software or hardware problems where call detail records may be lost.

Customers not able to obtain SMDR-P may subscribe to SMDR-RAO.

The customer must obtain and maintain a compatible modem and call accounting package for use with SMDR-P. A business exchange access line, Centrex Plus station line, or Voice Grade Channel is required to provide SMDR.

The standard call data retrieval/delivery interval for SMDR-P is once daily. Customers must specify the time-of-day interval when they wish to retrieve or have the Company deliver their call detail.

SMDR-P customers wishing to retrieve call detail at intervals other than once daily, will be priced on an individual case by case basis.

SMDR-P has two delivery options: modem to modem or File Transfer Protocol (FTP). The customer's data may be forwarded at a customer specified time.

**Qwest Corporation**  
**Exchange and Network**  
**Services Catalog No. 1**

**SECTION 109**  
Page 123  
Release 1

**SOUTHERN IDAHO**  
Issued: 7-1-2005

Effective: 8-1-2005

**109. OBSOLETE CENTRAL OFFICE SERVICES**

**109.1 DIAL SWITCHING SYSTEMS**

**109.1.16 CENTREX PLUS SERVICE**

F.15.b. (Cont'd)

Call data remains on disk for five calendar days after the initial distribution of data to the customer. During this time, customers may request one resend of previously sent data at no charge. After five days, the call data is transferred to magnetic tape. Each customer's daily call detail will be stored on tape and archived for 30 days. This archived information will be made available for retransmission to the customer. A nonrecurring charge will apply for the retrieval of this archived data.

The Company reserves all rights to take SMDR-P down for a four and one half hour period every night to run backups and perform maintenance routines.

For SMDR-RAO the magnetic tape(s) will be sent to the customer once a month based on the Company's bill period date. Customers wishing to receive tapes at intervals other than one a month, will be priced on an individual case by case basis.

SMDR-RAO call data is available only for the previous month. An additional nonrecurring charge will be applied if the customer requests a resend of a previously delivered tape.

All nonrecurring charges for SMDR will be applied on a per common block system basis.

A Service Establishment Charge will be applied when all working and non-working station numbers in the customer's Centrex Plus customer group are loaded into the SMDR database at the time of initial installation of the system.

A retransmission of archived SMDR call detail charge, will be applied if a SMDR-P customer desires a resend of call detail originally transmitted within the previous 30 days.

Requests for SMDR call detail in a manner other than described herein will be considered non-standard and will be priced based upon individual customer requirements, cost and rate levels on a case by case basis. Non-standard provisioning of SMDR may include customer requests for local call detail, Company delivery of data for SMDR-P customers, or hourly retrieval of call data for SMDR-P customers.

**NOTICE**  
**THE INFORMATION CONTAINED IN THIS DOCUMENT IS SUBJECT TO CHANGE.**

**Qwest Corporation**  
**Exchange and Network**  
**Services Catalog No. 1**

**SECTION 109**  
Page 124  
Release 1

**SOUTHERN IDAHO**  
Issued: 7-1-2005

Effective: 8-1-2005

**109. OBSOLETE CENTRAL OFFICE SERVICES**

**109.1 DIAL SWITCHING SYSTEMS**

**109.1.16 CENTREX PLUS SERVICE**

F.15.[1] (Cont'd)

c. Rates and Charges

	<b>USOC</b>	<b>NONRECURRING CHARGE</b>
• Service Establishment Charge, initial installation, per customer group		
- SMDR-P	SESP	\$340.00
- SMDR-RAO	SEPSR	240.00
• Retransmission of archived call detail, per request[2]		
- SMDR-P	REH1X	300.00
• Non-Standard provision of SMDR, per main station line	S6N	[3]

[1] Customers signing a contract after April 23, 1993, will receive SMDR at rates and charges specified in the section. Customers that have RSP Arrangements prior to April 23, 1993 must sign a new RSP Arrangement to have SMDR from this section.

[2] A request shall not exceed 7 consecutive calendar days.

[3] Rates and charges will be based on an individual case basis per customer request.

**NOTICE**  
**THE INFORMATION CONTAINED IN THIS DOCUMENT IS SUBJECT TO CHANGE.**

**Qwest Corporation**  
**Exchange and Network**  
**Services Catalog No. 1**

**SECTION 109**  
Page 125  
Release 1

**SOUTHERN IDAHO**  
Issued: 7-1-2005

Effective: 8-1-2005

**109. OBSOLETE CENTRAL OFFICE SERVICES**

**109.1 DIAL SWITCHING SYSTEMS**

**109.1.16 CENTREX PLUS SERVICE**

F. Rates and Charges - Optional Service Features (Cont'd)

16. Time of Day Routing[1]

Enables efficient use of facilities by allowing or denying route choices based on time of day.

	<b>USOC</b>	<b>INSTALLATION CHARGE</b>	<b>MONTHLY RATE</b>
• Per main station line	ATB	\$1.00	\$0.10
• Per ARS pattern	ATBPZ	5.00	2.00

17. Time of Day NCOS (Network Class of Service) Update[1]

Allows normal NCOS values to be mapped on to new values that are based on time of day, day of the week, or day of the year.

	<b>USOC</b>	<b>INSTALLATION CHARGE</b>	<b>MONTHLY RATE</b>
• Per main station line	A4T	\$1.00	\$0.10

[1] Available only from a DMS-100 Central Office.

**Qwest Corporation**  
**Exchange and Network**  
**Services Catalog No. 1**

**SECTION 109**  
Page 126  
Release 1

**SOUTHERN IDAHO**  
Issued: 7-1-2005

Effective: 8-1-2005

**109. OBSOLETE CENTRAL OFFICE SERVICES**

**109.1 DIAL SWITCHING SYSTEMS**

**109.1.16 CENTREX PLUS SERVICE**

F. Rates and Charges - Optional Service Features (Cont'd)

18. Uniform Call Distribution

This feature is a type of hunting which provides for an even distribution of incoming calls among the available members of a hunt group.

	USOC	INSTALLATION CHARGE	MONTHLY RATE
• UCD in hunt group including Queuing, Music on Queue and Delay Announcement[1]			
- Per group	MHMPG	\$215.00	-
- Per main station line	MHM	16.00	\$ 5.50
• Make Busy Arrangements,			
- Per group[2,3]	A9AEX	20.00	50.00
- Per line[2,3]	MB1	20.00	3.50
• Call Waiting Indication, per unique timing state[4]	WUT	25.00	13.50

[1] Limit of one announcement channel per UCD system.

[2] This arrangement is only available from a 5E and 1AESS Central Office.

[3] A Low Speed Data channel from the Access Service Catalog and a special set with a Make Busy Key is required.

[4] In addition, for each unique timing state only rates and charges for a Narrowband Channel from the Access Service Catalog apply. Limit of three unique timing states per UCD system.

**NOTICE**  
**THE INFORMATION CONTAINED IN THIS DOCUMENT IS SUBJECT TO CHANGE.**

**Qwest Corporation**  
**Exchange and Network**  
**Services Catalog No. 1**

**SECTION 109**  
Page 127  
Release 1

**SOUTHERN IDAHO**  
Issued: 7-1-2005

Effective: 8-1-2005

**109. OBSOLETE CENTRAL OFFICE SERVICES**

**109.1 DIAL SWITCHING SYSTEMS**

**109.1.16 CENTREX PLUS SERVICE**

F. Rates and Charges - Optional Service Features (Cont'd)

19. Call Forward Don't Answer/Call Forward Busy Customer Programmable

Enables users to activate, deactivate and re-direct the Call Forward Busy and Call Forward Don't Answer features from their stations by using dialed feature access codes.

	<b>USOC</b>	<b>INSTALLATION CHARGE</b>	<b>MONTHLY RATE</b>
• Service establishment	SEPFA	\$100.00	—
• Per line	FSW	15.00	\$0.40

20. Music on Hold[1,2]

Provides Music on Hold to all stations excluding Electronic Set Service.

	<b>USOC</b>	<b>INSTALLATION CHARGE</b>	<b>MONTHLY RATE</b>
• Per System	MHPS	\$250.00	\$55.00

[1] Available only from a DMS-100 Central Office.

[2] Requires a Voice Grade circuit found elsewhere.

**NOTICE**  
**THE INFORMATION CONTAINED IN THIS DOCUMENT IS SUBJECT TO CHANGE.**

**Qwest Corporation**  
**Exchange and Network**  
**Services Catalog No. 1**

**SECTION 109**  
Page 128  
Release 1

**SOUTHERN IDAHO**  
Issued: 7-1-2005

Effective: 8-1-2005

**109. OBSOLETE CENTRAL OFFICE SERVICES**

**109.1 DIAL SWITCHING SYSTEMS**

**109.1.16 CENTREX PLUS SERVICE**

F. Rates and Charges - Optional Service Features (Cont'd)

22. Trunk Verification From Designated Station[1]

Allows end users audible transmission level testing for selected trunks within a trunk group, limit of ten stations per system.

	<b>USOC</b>	<b>INSTALLATION CHARGE</b>	<b>MONTHLY RATE</b>
• Per line equipped	BVS	\$250.00	\$15.00

[1] Limit of one announcement channel per UCD system.

**NOTICE**  
**THE INFORMATION CONTAINED IN THIS DOCUMENT IS SUBJECT TO CHANGE.**

**Qwest Corporation**  
**Exchange and Network**  
**Services Catalog No. 1**

**SECTION 109**  
Page 129  
Release 1  
Effective: 8-1-2005

**SOUTHERN IDAHO**  
Issued: 7-1-2005

**109. OBSOLETE CENTRAL OFFICE SERVICES**

**109.1 DIAL SWITCHING SYSTEMS**

**109.1.16 CENTREX PLUS SERVICE (Cont'd)**

G. Rate Stabilized Common Line Facilities - Superceded Price List[1]

1. Common Line Facilities, per location

**USOC**

- Rate stabilized flat station line,  
extension station line, blocked, each[2]

**RHN/X5S**

	<b>12 TO 35 MONTHS</b>	<b>36 TO 59 MONTHS</b>	<b>60 TO 84 MONTHS</b>
1 - 20 station lines	\$20.00	\$18.00	\$15.00
21 - 50 station lines,	17.33	14.44	13.00
51 station lines and over			
1 Qtr mile from CO	4.99	4.16	3.74
2 Qtr miles from CO	5.39	4.49	4.04
3 Qtr miles from CO	5.81	4.84	4.36
4 Qtr miles from CO	6.37	5.31	4.78
5 Qtr miles from CO	6.84	5.70	5.13
6 Qtr miles from CO	7.35	6.12	5.51
7 Qtr miles from CO	8.00	6.67	6.00
8 Qtr miles from CO	8.51	7.09	6.38
9 Qtr miles from CO	9.32	7.77	6.99
10 Qtr miles from CO	10.97	9.14	8.23
11 Qtr miles from CO	11.71	9.76	8.78
12 Qtr miles from CO	14.04	11.70	10.53
13 Qtr miles from CO	15.91	13.26	11.93
14 Qtr miles from CO	16.64	13.87	12.48
15 Qtr miles from CO	17.81	14.84	13.36
16 Qtr miles from CO	20.51	17.09	15.38
17 Qtr miles from CO	21.40	17.83	16.05
18 Qtr miles from CO	22.15	18.46	16.61
19 Qtr miles from CO	23.00	19.02	17.12
20 Qtr miles from CO	23.00	22.23	20.01

[1] Rates and charges found on this superceded Price List were in effect February 20, 1992 through April 23, 1993.

[2] In addition, the End User Common Line Charge applies to each Common Line Facility.

**NOTICE**  
**THE INFORMATION CONTAINED IN THIS DOCUMENT IS SUBJECT TO CHANGE.**

**Qwest Corporation**  
**Exchange and Network**  
**Services Catalog No. 1**

**SECTION 109**  
Page 130  
Release 1

**SOUTHERN IDAHO**  
Issued: 7-1-2005

Effective: 8-1-2005

**109. OBSOLETE CENTRAL OFFICE SERVICES**

**109.1 DIAL SWITCHING SYSTEMS**

**109.1.16 CENTREX PLUS SERVICE**

G.1.[1] (Cont'd)

**USOC**

- Rate stabilized flat station line, extension station line, blocked, non-blocked, each[2]

**RHN/X5S**

	<b>12 TO 35 MONTHS</b>	<b>36 TO 59 MONTHS</b>	<b>60 TO 84 MONTHS</b>
1 - 20 station lines	\$20.00	\$18.00	\$15.00
21 - 50 station lines,	17.33	14.44	13.00
51 station lines and over			
1 Qtr mile from CO	4.99	4.16	3.74
2 Qtr miles from CO	5.39	4.49	4.04
3 Qtr miles from CO	5.81	4.84	4.36
4 Qtr miles from CO	6.37	5.31	4.78
5 Qtr miles from CO	6.84	5.70	5.13
6 Qtr miles from CO	7.35	6.12	5.51
7 Qtr miles from CO	8.00	6.67	6.00
8 Qtr miles from CO	8.51	7.09	6.38
9 Qtr miles from CO	9.32	7.77	6.99
10 Qtr miles from CO	10.97	9.14	8.23
11 Qtr miles from CO	11.71	9.76	8.78
12 Qtr miles from CO	14.04	11.70	10.53
13 Qtr miles from CO	15.91	13.26	11.93
14 Qtr miles from CO	16.64	13.87	12.48
15 Qtr miles from CO	17.81	14.84	13.36
16 Qtr miles from CO	20.51	17.09	15.38
17 Qtr miles from CO	21.40	17.83	16.05
18 Qtr miles from CO	22.15	18.46	16.61
19 Qtr miles from CO	23.00	19.02	17.12
20 Qtr miles from CO	23.00	22.23	20.01

[1] Rates and charges found on this superceded Price List were in effect February 20, 1992 through April 23, 1993.

[2] In addition, the End User Common Line Charge applies to each Common Line Facility.

**NOTICE**  
**THE INFORMATION CONTAINED IN THIS DOCUMENT IS SUBJECT TO CHANGE.**

**Qwest Corporation**  
**Exchange and Network**  
**Services Catalog No. 1**

**SECTION 109**  
Page 131  
Release 1

**SOUTHERN IDAHO**  
Issued: 7-1-2005

Effective: 8-1-2005

**109. OBSOLETE CENTRAL OFFICE SERVICES**

**109.1 DIAL SWITCHING SYSTEMS**

**109.1.16 CENTREX PLUS SERVICE**

G.1.[1] (Cont'd)

**USOC**

- Rate stabilized flat station line, extension station line, blocked, each [2]

**RHN/X5S**

	<b>12 TO 35 MONTHS</b>	<b>36 TO 59 MONTHS</b>	<b>60 TO 84 MONTHS</b>
1 - 20 station lines	\$20.00	\$18.00	\$15.00
21 - 50 station lines	17.33	14.44	13.00
51 station lines and over			
1 Qtr mile from CO	5.48	4.57	4.11
2 Qtr miles from CO	5.88	4.90	4.41
3 Qtr miles from CO	6.31	5.26	4.73
4 Qtr miles from CO	6.87	5.72	5.15
5 Qtr miles from CO	7.34	6.11	5.50
6 Qtr miles from CO	7.84	6.54	5.88
7 Qtr miles from CO	8.50	7.08	6.37
8 Qtr miles from CO	9.00	7.50	6.75
9 Qtr miles from CO	9.82	8.18	7.36
10 Qtr miles from CO	11.47	9.56	8.60
11 Qtr miles from CO	12.20	10.17	9.15
12 Qtr miles from CO	14.54	12.11	10.90
13 Qtr miles from CO	16.40	13.67	12.30
14 Qtr miles from CO	17.14	14.28	12.85
15 Qtr miles from CO	18.31	15.26	13.73
16 Qtr miles from CO	21.00	17.50	15.75
17 Qtr miles from CO	21.90	18.25	16.42
18 Qtr miles from CO	22.64	18.87	16.98
19 Qtr miles from CO	23.32	19.44	17.49
20 Qtr miles from CO	27.18	22.65	20.38

[1] Rates found in this superceded Price List were in effect April 23, 1993 through October 17, 1993.

[2] In addition, the End User Common Line Charge applies to each Common Line facility.

**NOTICE**  
**THE INFORMATION CONTAINED IN THIS DOCUMENT IS SUBJECT TO CHANGE.**

**Qwest Corporation**  
**Exchange and Network**  
**Services Catalog No. 1**

**SECTION 109**  
Page 132  
Release 1

**SOUTHERN IDAHO**  
Issued: 7-1-2005

Effective: 8-1-2005

**109. OBSOLETE CENTRAL OFFICE SERVICES**

**109.1 DIAL SWITCHING SYSTEMS**

**109.1.16 CENTREX PLUS SERVICE**

G.1.[1] (Cont'd)

**USOC**

- Rate stabilized flat station line, extension station line, blocked, each [2]

**RHN/X5S**

	<b>12 TO 35 MONTHS</b>	<b>36 TO 59 MONTHS</b>	<b>60 TO 84 MONTHS</b>
51 station lines and over			
21 Qtr miles from CO	\$27.46	\$22.88	\$20.59
22 Qtr miles from CO	27.74	23.11	20.80
23 Qtr miles from CO	28.02	23.35	21.01
24 Qtr miles from CO	28.30	23.58	21.22
25 Qtr miles from CO	28.58	23.81	21.43
26 Qtr miles from CO	28.86	24.05	21.64
27 Qtr miles from CO	29.14	24.28	21.85
28 Qtr miles from CO	29.42	24.51	22.06
29 Qtr miles from CO	29.70	24.75	22.27
30 Qtr miles from CO	29.98	24.98	22.48
31 Qtr miles from CO	30.26	25.21	22.69
32 Qtr miles from CO	30.54	25.45	22.90
33 Qtr miles from CO	30.82	25.68	23.11
34 Qtr miles from CO	31.10	25.91	23.32
35 Qtr miles from CO	31.38	26.15	23.53
36 Qtr miles from CO	31.66	26.38	23.74
37 Qtr miles from CO	31.94	26.61	23.95
38 Qtr miles from CO	32.22	26.85	24.16
39 Qtr miles from CO	32.50	27.08	24.37
40 Qtr miles from CO	32.72	27.27	24.54

[1] Rates found in this superseded Price List were in effect April 23, 1993 through October 17, 1993.

[2] In addition, the End User Common Line Charge applies to each Common Line facility.

**NOTICE**  
**THE INFORMATION CONTAINED IN THIS DOCUMENT IS SUBJECT TO CHANGE.**

**Qwest Corporation**  
**Exchange and Network**  
**Services Catalog No. 1**

**SECTION 109**  
Page 133  
Release 1

**SOUTHERN IDAHO**  
Issued: 7-1-2005

Effective: 8-1-2005

**109. OBSOLETE CENTRAL OFFICE SERVICES**

**109.1 DIAL SWITCHING SYSTEMS**

**109.1.16 CENTREX PLUS SERVICE**

G.1.[1] (Cont'd)

**USOC**

- Rate stabilized flat station line, extension station line, non-blocked, each[2]

**R4H/R5S**

	<b>12 TO 35 MONTHS</b>	<b>36 TO 59 MONTHS</b>	<b>60 TO 84 MONTHS</b>
1 - 20 station lines	\$20.00	\$18.00	\$15.00
21 - 50 station lines	17.33	14.44	13.00
51 station lines and over			
1 Qtr mile from CO	5.48	4.57	4.11
2 Qtr miles from CO	5.88	4.90	4.41
3 Qtr miles from CO	6.31	5.26	4.73
4 Qtr miles from CO	6.87	5.72	5.15
5 Qtr miles from CO	7.34	6.11	5.50
6 Qtr miles from CO	7.84	6.54	5.88
7 Qtr miles from CO	8.50	7.08	6.37
8 Qtr miles from CO	9.00	7.50	6.75
9 Qtr miles from CO	9.82	8.18	7.36
10 Qtr miles from CO	11.47	9.56	8.60
11 Qtr miles from CO	14.54	12.11	10.90
13 Qtr miles from CO	16.40	13.67	12.30
14 Qtr miles from CO	17.14	14.28	12.85
15 Qtr miles from CO	18.31	15.26	13.73
16 Qtr miles from CO	21.00	17.50	15.75
17 Qtr miles from CO	21.90	18.25	16.42
18 Qtr miles from CO	22.64	18.87	16.98
19 Qtr miles from CO	23.32	19.44	17.49
20 Qtr miles from CO	27.18	22.65	20.38

[1] Rates found in this superseded Price List were in effect April 23, 1993 through October 17, 1993.

[2] In addition, the End User Common Line Charge applies to each Common Line facility.

**NOTICE**  
**THE INFORMATION CONTAINED IN THIS DOCUMENT IS SUBJECT TO CHANGE.**

**Qwest Corporation**  
**Exchange and Network**  
**Services Catalog No. 1**

**SECTION 109**  
Page 134  
Release 1

**SOUTHERN IDAHO**  
Issued: 7-1-2005

Effective: 8-1-2005

**109. OBSOLETE CENTRAL OFFICE SERVICES**

**109.1 DIAL SWITCHING SYSTEMS**

**109.1.16 CENTREX PLUS SERVICE**

G.1.[1] (Cont'd)

**USOC**

- Rate stabilized flat station line, extension station line, non-blocked, each[2]

**R4H/R5S**

	<b>12 TO 35 MONTHS</b>	<b>36 TO 59 MONTHS</b>	<b>60 TO 84 MONTHS</b>
51 station lines and over			
21 Qtr miles from CO	\$27.46	\$22.88	\$20.59
22 Qtr miles from CO	27.74	23.11	20.80
23 Qtr miles from CO	28.02	23.35	21.01
24 Qtr miles from CO	28.30	23.58	21.22
25 Qtr miles from CO	28.58	23.81	21.43
26 Qtr miles from CO	28.86	24.05	21.64
27 Qtr miles from CO	29.14	24.28	21.85
28 Qtr miles from CO	29.42	24.51	22.06
29 Qtr miles from CO	29.70	24.75	22.27
30 Qtr miles from CO	29.98	24.98	22.48
31 Qtr miles from CO	30.26	25.21	22.69
32 Qtr miles from CO	30.54	25.45	22.90
33 Qtr miles from CO	30.82	25.68	23.11
34 Qtr miles from CO	31.10	25.91	23.32
35 Qtr miles from CO	31.38	26.15	23.53
36 Qtr miles from CO	31.66	26.38	23.74
37 Qtr miles from CO	31.94	26.61	23.95
38 Qtr miles from CO	32.22	26.85	24.16
39 Qtr miles from CO	32.50	27.08	24.37
40 Qtr miles from CO	32.72	27.27	24.54

[1] Rates found in this superseded Price List were in effect April 23, 1993 through October 17, 1993.

[2] In addition, the End User Common Line Charge applies to each Common Line facility.

**NOTICE**  
**THE INFORMATION CONTAINED IN THIS DOCUMENT IS SUBJECT TO CHANGE.**

**Qwest Corporation**  
Exchange and Network  
Services Catalog No. 1

**SECTION 109**  
Page 135  
Release 2  
Effective: 7-31-2006

**SOUTHERN IDAHO**  
Issued: 7-21-2006

**109. OBSOLETE CENTRAL OFFICE SERVICES**

**109.1 DIAL SWITCHING SYSTEMS (Cont'd)**

**109.1.17 CENTREX 21 SERVICE**

Effective April 11, 2005, Centrex 21 Service is obsolete. Customers will be allowed to retain their obsolete service only as long as service remains at the same location. The service may be transferred between customers (supersede) in accordance with 2.2.1.E., preceding.

(C)  
(C)  
(C)

A. Description

1. Centrex 21 Service is a flat rate, business service for customers with 2 to 50 station lines. Centrex 21 Service is furnished only from a Stored Program Controlled central office offered subject to the availability of facilities and applicable generic feature programs and will not be available in a 2BESS Central Office. Centrex 21 consists of standard features which are available to all station lines in the shared customer group where available. A Centrex 21 customer has a choice of having the features delivered via analog lines and/or 2B+S, (digital, voice only) ISDN lines. Optional features are also available.
2. Centrex 21 standard features include the following features depending upon the serving central office:

FEATURE	ANALOG	DIGITAL VOICE
• Primary DN	X	X
• Secondary DN	-	X
• Multiple Shared		
Call Appearances of a DN	-	X
• Call Drop	-	X
• Call Exclusion	-	X
• Call Forwarding - Busy Line	X	X
• Call Forwarding - Don't Answer	X	X
• Call Forwarding - Variable	X	X
• Call Hold	X	X
• Calling Identity Delivery on		
Call Waiting Number	X	-
• Call Pickup	X	X
• Call Transfer	X	X
• Call Waiting	X	-
• Caller Identification Number	X	-
• Conference Calling		
- 3-Way	X	X
- 6-Way	X	X

NOTICE  
THE INFORMATION CONTAINED IN THIS DOCUMENT IS SUBJECT TO CHANGE.  
TRANSMITTAL NO. 06-07-SID

**Qwest Corporation**  
**Exchange and Network**  
**Services Catalog No. 1**

**SECTION 109**  
Page 136  
Release 1

**SOUTHERN IDAHO**  
Issued: 7-1-2005

Effective: 8-1-2005

**109. OBSOLETE CENTRAL OFFICE SERVICES**

**109.1 DIAL SWITCHING SYSTEMS**

**109.1.17 CENTREX 21 SERVICE**

A.2. (Cont'd)

FEATURE	ANALOG	DIGITAL VOICE
• Direct Dialing/Originating Terminating	X	X
• Display	-	X
• Hunting	X	X
• Individual Line Billing	X	X
• Intercept	X	X
• Incoming Calling Identification	-	X
• Message Waiting Service		
- Audible	X	X
- Visual	X	X
• Speed Calling	X	X
• Standard Configuration Group	-	X
• Touch-Tone	X	X

3. Centrex 21 optional features include the following features depending upon the serving central office:

FEATURE	ANALOG	DIGITAL VOICE
• Additional Secondary Directory Number	-	X
• Analog Call Appearance	-	X
• Call Park	X	-
• Caller Identification Name and Number	X	-
• Minutes Free Calling Plan	X	-
• 2B+D (Circuit Switched Data)	-	X
• Electronic Business Set	X	-
• Nonstandard Configuration Group	-	X
• Remote Access Forwarding	X	-
• Scheduled Call Forwarding	X	-

**NOTICE**  
**THE INFORMATION CONTAINED IN THIS DOCUMENT IS SUBJECT TO CHANGE.**

## **109. OBSOLETE CENTRAL OFFICE SERVICES**

### **109.1 DIAL SWITCHING SYSTEMS**

#### **109.1.17 CENTREX 21 SERVICE (Cont'd)**

##### **B. Terms and Conditions**

1. Centrex 21 Service ISDN station lines will be offered, from the customer's local serving Central Office only. ISDN Service from the Central Office is generally considered "available" for loops of 18 kilofeet or less in length. Loops greater than 18 kilofeet in length must meet extension technology design requirements. Service will be considered available if ISDN compatible pair gain systems or single line loop extension equipment are in place to serve the area.
2. Rates and charges for the Centrex 21 ISDN 2B+S, (digital, voice only) lines do not include extended ISDN availability arrangements. Extended ISDN availability arrangements are only available on an individual case basis.
3. Centrex 21 Service equips the station lines in the system with all the standard features. Customers subscribing to this service are required to pay the monthly rates for service, whether or not all standard features are activated at initial installation.
4. The monthly rate for Centrex 21 Service covered under the Rate Stabilized Plan is guaranteed against Company initiated changes for the duration of the plan. The minimum Rate Stabilized Plan is 12 months. The maximum Rate Stabilized period is 60 months.
5. Customers subscribing to an unexpired standard Rate Stability Plan as of April 11, 2005, may add station lines to an existing system at any time during the Rate Stability Plan period at the rates originally applicable to that customer. Customers whose station line growth exceeds 50 station lines have the option to convert to other Company Services. The service period for converted Company Services will bear the same expiration date as that of the customer's original Rate Stability Plan.
6. Customers will be responsible to furnish all premises wiring, terminal equipment and jacks used with the Centrex 21 Service.
7. All Centrex 21 Service station lines must be associated with the same customer group.
8. Customer request for temporary suspension, either full or partial, of Centrex 21 Service is not permitted. Seasonal disconnects are not allowed.

**NOTICE**  
**THE INFORMATION CONTAINED IN THIS DOCUMENT IS SUBJECT TO CHANGE.**

**Qwest Corporation**  
**Exchange and Network**  
**Services Catalog No. 1**

**SECTION 109**  
Page 138  
Release 1

**SOUTHERN IDAHO**  
Issued: 7-1-2005

Effective: 8-1-2005

**109. OBSOLETE CENTRAL OFFICE SERVICES**

**109.1 DIAL SWITCHING SYSTEMS**

**109.1.17 CENTREX 21 SERVICE**

B. Terms and Conditions (Cont'd)

9. One primary directory listing is furnished without charge for each Centrex 21 system. Directory listings of station lines may be provided at the regular business additional listing rate as specified in 5.7.1, preceding.
10. Intercept Service will be provided on the main listed directory number for a total system disconnect only.
11. Customers may reserve additional telephone numbers for future use at the rates specified in 5.3.4, preceding.
12. If a customer terminates the agreement before the established service date, in whole or in part, the customer will pay cancellation charges as defined under the Termination Liability/Waiver Policy as set forth in 2.2.14, preceding.
13. After the service date, if a customer with a fixed-period rate plan removes, in whole or in part, station lines to a level less than 70% of the initial number of station lines, a termination charge may apply, as defined in 2.2.14, preceding.
14. The customer may substitute Centrex 21 Service with another Company service that functionally replaces Centrex 21 Service and provides equivalent or greater feature functionality as defined in 2.2.14, preceding.
15. Centrex 21 Service is not available on Public Communications Service or multiparty service.
16. Each customer will be required to sign a contractual agreement for the furnishing of services on a rate stabilized basis.
17. Caller Identification Blocking - Per Call and Caller Identification Blocking - Per Line as defined in 10.7.1 and 10.7.2, following, is available with Centrex 21 Service.
18. Electronic Business Set will be provided from a DMS-100 Central Office and only where facilities permit.

**NOTICE**  
**THE INFORMATION CONTAINED IN THIS DOCUMENT IS SUBJECT TO CHANGE.**

## **109. OBSOLETE CENTRAL OFFICE SERVICES**

### **109.1 DIAL SWITCHING SYSTEMS**

#### **109.1.17 CENTREX 21 SERVICE**

##### **B. Terms and Conditions (Cont'd)**

19. Each electronic set must be associated with a Primary Directory Number. In addition, an Electronic Business Set interface card is required.
20. Electronic Business Set is subject to a 1.5 mile limitation from the central office.
21. Electronic Business Set is only available on Centrex 21 main station lines. Main station lines with electronic sets cannot have extension stations; however, the primary directory number associated with the main station line can appear as a secondary appearance of a primary directory number on other main station lines.
22. A termination charge will be waived when customers change to Business Line Volume Purchase Plan.
23. For customers with a standard RSP on or after April 11, 2005, the Termination Liability will be waived when changing to a *QWEST* voice line service
24. If a customer terminates the agreement before the established service date, in whole or in part, the customer will pay cancellation charges as defined under the Termination Liability/Waiver Policy as set forth in C., following.
25. After the service date, if a customer with a fixed-period rate plan removes, in whole or in part, station lines to a level less than 70% of the initial number of station lines, a termination charge may apply, as defined in C., following.
26. The customer may substitute Centrex 21 Service with another Company service that functionally replaces Centrex 21 Service and provides equivalent or greater feature functionality as defined in C., following.
27. Customers subscribing to an unexpired standard Rate Stability Plan as of April 11, 2005, may add station lines to an existing system at the same location at the rates originally applicable to that customer.

## **109. OBSOLETE CENTRAL OFFICE SERVICES**

### **109.1 DIAL SWITCHING SYSTEMS**

#### **109.1.17 CENTREX 21 SERVICE (Cont'd)**

##### **C. Termination Liability/Waiver Policy**

Centrex 21 Service provided via service agreements may be subject to the Termination Liability/Waiver Policy.

##### **1. Definitions**

###### Minimum Billing Level

When Centrex 21 Service is provided under a service agreement, a Minimum Billing Level will be established for use in calculating discontinuance charges. The Minimum Billing Level is 100% percent of the total monthly rates for the service provided under the customer's service agreement, unless otherwise specified.

###### Minimum Service Period

When Centrex 21 Service is provided under a service agreement, a Minimum Service Period may be established. This would be the period of time that the 100% factor of the Termination Liability Charge would apply.

##### **2. Complete Disconnect**

If the customer chooses to completely discontinue Centrex 21 Service, at any time during the term of the agreement, a termination charge will apply, unless the customer satisfies the conditions specified in the Waiver Policy. The termination charge is 100% of the rates for the Minimum Service Period, if applicable plus the Minimum Billing Level multiplied by the termination liability percentage specified in the service agreement, for the remaining term of the agreement.

- For example, if the customer discontinues Centrex 21 Service after 17 months of a 3-year (36 month) agreement, the termination charge will be the Minimum Billing Level for the service, multiplied by the termination liability percentage, multiplied by 19 months.
- If the customer discontinues Centrex 21 Service after 6 months of a 3-year (36 months) agreement, with a 1-year (12 months) Minimum Service Period, the Termination Charge will be 100% of the Minimum Billing Level for the remaining 6 months of the Minimum Service Period, plus the Minimum billing Level multiplied by the termination liability percentage, multiplied by 24 months.

**Qwest Corporation**  
**Exchange and Network**  
**Services Catalog No. 1**

**SECTION 109**  
Page 141  
Release 1

**SOUTHERN IDAHO**  
Issued: 7-1-2005

Effective: 8-1-2005

**109. OBSOLETE CENTRAL OFFICE SERVICES**

**109.1 DIAL SWITCHING SYSTEMS**

**109.1.17 CENTREX 21 SERVICE**

C. Termination Liability/Waiver Policy (Cont'd)

(T)(M)

3. Partial Disconnect

If the customer discontinues a portion of their Centrex 21 Service, and that causes the customer's monthly billing level to fall below the Minimum Billing Level of the agreement, a termination charge will apply to the portion of the service agreement that is below the Minimum Billing Level.

4. Waiver Policy

A termination charge will be waived when the customer discontinues their contracted Centrex 21 Service, provided all of the following conditions are met:

- The customer signs a new service agreement for any other Company provided service(s);
- Both the existing and the new service(s) are provided solely by the Company;
- The order to discontinue the existing service(s) and the order to establish the new service(s) are received by the Company at the same time;
- The new service(s) installation must be completed within thirty calendar days of the disconnection of the old service(s), unless the installation delay is caused by the Company;
- The total value of the new service agreement(s), excluding any special construction charges and any other nonrecurring charges, is equal to or greater than 115% of the remaining value of the existing agreement(s);
- A new minimum service period goes into effect when the new service agreement term begins;
- The customer agrees to pay any previously billed, but unpaid recurring, and any outstanding nonrecurring charges. The charges cannot be included as part of the new service agreement;
- All applicable nonrecurring charges will be assessed for the new contracted service(s).

(M)

(N)

(N)

**NOTICE**  
**THE INFORMATION CONTAINED IN THIS DOCUMENT IS SUBJECT TO CHANGE.**

## **109. OBSOLETE CENTRAL OFFICE SERVICES**

### **109.1 DIAL SWITCHING SYSTEMS**

#### **109.1.17 CENTREX 21 SERVICE (Cont'd)**

##### C. Standard Service Feature - Description

###### Primary Directory Number (PDN)[1]

Each terminal is assigned one Primary Directory Number. If more than two terminals are attached to a Basic Rate Access Connection, additional Primary Directory Numbers will be required. The maximum allowable number of Call Appearances (PDN, SDN or shared) will be determined by the CPE and configuration groups selected.

###### Secondary Directory Number (SDN)

A Secondary Directory number is any directory number, other than the Primary Directory Number, assigned to an ISDN terminal. The standard package includes one SDN. The maximum allowable number of Call Appearances (PDN, SDN or shared) will be determined by the CPE and configuration groups selected.

###### Multiple Shared Call Appearances of a Directory Number[2]

This feature allows several station sets to share one or more Call Appearances of a particular directory number (PDN or SDN). The originating and terminating events on one station set affects all stations that share Call Appearances for a particular directory number. The shared directory number can have up to eight Call Appearances. Multiple calls can exist on one directory number and more than one station sharing the directory number can have a call active on the shared directory number.

[1] Customers may choose from any of the existing standard configuration groups for their system.

[2] On a DMS-100 Central Office, this feature requires MADN as well.

## **109. OBSOLETE CENTRAL OFFICE SERVICES**

### **109.1 DIAL SWITCHING SYSTEMS**

#### **109.1.17 CENTREX 21 SERVICE**

##### C. Standard Service Feature - Description (Cont'd)

###### Call Drop

This feature allows the user (who is the controller of a call) to drop the last party that was added to a conference call. Also, this feature allows a user to disconnect a 2-party call.

###### Call Exclusion

Manual Call Exclusion restricts other stations from picking up a call on hold or bridging onto an active call at that station.

###### Call Forwarding Busy Line

Provides for forwarding of "all" calls to a preselected telephone number when the called station is busy.

###### Call Forwarding Don't Answer

Provides for forwarding of "all" calls to a preselected telephone number, when the called station does not answer after a predetermined number of ringing cycles.

###### Call Forwarding-Variable

Allows a user to automatically forward "all" calls to any other number.

###### Call Hold[1]

Allows a station user to hold any call in progress by dialing a code.

###### Calling Identity Delivery on Call Waiting - Number[2,3]

Provides calling number delivery following the call waiting tone.

[1] Provided by proprietary CPE on ISDN.

[2] Requires CPE that has a display.

[3] Not available from DMS-10, DMS-100, and AXE -10 Central Offices.

**Qwest Corporation**  
**Exchange and Network**  
**Services Catalog No. 1**

**SECTION 109**  
Page 144  
Release 1

**SOUTHERN IDAHO**  
Issued: 7-1-2005

Effective: 8-1-2005

**109. OBSOLETE CENTRAL OFFICE SERVICES**

**109.1 DIAL SWITCHING SYSTEMS**

**109.1.17 CENTREX 21 SERVICE**

C. Standard Service Feature - Description (Cont'd)

Call Pick-Up

Enables a station user to answer calls directed to other specified stations by dialing a special code.

Call Transfer

Allows a station line user to transfer any established call to another station line without the assistance of an attendant. This feature also utilizes the switchhook to put a caller on consultation hold.

Call Waiting

- Terminating - All Calls
  - Allows for a Centrex 21 station user who is engaged in a telephone conversation to be alerted via an audible tone that a call is waiting if the called station line is busy.
- Cancel Call Waiting
  - Permits a Call Waiting customer to inhibit the call waiting operation for one call through the use of a cancel call waiting code.

NOTICE  
THE INFORMATION CONTAINED IN THIS DOCUMENT IS SUBJECT TO CHANGE.

**Qwest Corporation**  
**Exchange and Network**  
**Services Catalog No. 1**

**SECTION 109**  
Page 145  
Release 1

**SOUTHERN IDAHO**  
Issued: 7-1-2005

Effective: 8-1-2005

**109. OBSOLETE CENTRAL OFFICE SERVICES**

**109.1 DIAL SWITCHING SYSTEMS**

**109.1.17 CENTREX 21 SERVICE**

C. Standard Service Feature - Description (Cont'd)

Caller Identification - Number[1]

Provides visual indication of the calling number from an outside party, assuming the incoming call has calling party number associated with it and the originating caller has not blocked presentation of calling party number.

Conference Calling

Allows a station user to establish conference connections without the aid of attendant or operator assistance. 3-Way allows a station in the talking state to add a third party to the call; 6-Way allows a station user to add up to five other parties.

Direct Dialing/Originating Terminating

Allows station users to place or receive calls.

Display[1]

Identifies incoming internal (i.e., intrasystem-system) calls by phone number and call type (e.g., internal, external, forwarded). This feature identifies why calls have forwarded from a specific number (e.g., busy, no answer). Requires electronic set equipped with appropriate alphanumeric LCD.

[1] Requires CPE that has a display.

## **109. OBSOLETE CENTRAL OFFICE SERVICES**

### **109.1 DIAL SWITCHING SYSTEMS**

#### **109.1.17 CENTREX 21 SERVICE**

##### C. Standard Service Feature - Description (Cont'd)

##### Hunting

- Automatically re-routes incoming calls to other lines when the calls encounter busy lines. Hunting groups provide a software-defined search for an available Call Appearance to which a call can be completed. A hunt group member is defined as a set of Call Appearances at the ISDN station.
  - Multi-Line Hunt Group (MLHG) - provides a sequential hunt over the members in the Multi-Line Hunt Group. When a Call Appearance is busy, the system sequentially hunts only the members following the member associated with the dialed number.
  - Circular Hunting - allows all lines in a multi-line hunt group to be tested for busy, regardless of the point of entry into the group. When a call is made to a line in a Multi-Line Hunt Group, a regular hunt is performed starting at the station associated with the dialed number. It continues to the last station of the Multi-Line Hunt Group then proceeds to the first station in the group and continues to hunt sequentially through the remaining lines in the group.
  - Series Completion - this feature allows calls made to a busy directory number to be routed to another specified directory number. The series completion hunting begins with the originally dialed member of the series completion group and searches for an idle directory number from the list of directory numbers.

##### Individual Line Billing

Toll calls are billed directly against the line placing the call.

##### Intercept

Disconnected or unassigned lines can be advised of a new number or given a disconnect recording.

## **109. OBSOLETE CENTRAL OFFICE SERVICES**

### **109.1 DIAL SWITCHING SYSTEMS**

#### **109.1.17 CENTREX 21 SERVICE**

##### C. Standard Service Feature - Description (Cont'd)

##### Incoming Calling Identification[1]

Provides user with visual feedback concerning the calling number from an outside party, assuming they do not have Call Blocking, when the electronic set is equipped with appropriate alphanumeric LCD. Name is not available with ISDN.

##### Message Waiting Service

- Audible Waiting Indication - when a user goes off hook a stutter dial tone is provided to indicate a message is waiting.
- Visual Waiting Indication - provides a message waiting indication on an electronic set via a message waiting lamp.[2]

##### Speed Calling

Allows a user to place calls to a list of frequently dialed numbers by dialing a one digit speed calling code for a 6 number list, or a 2 digit speed calling code for a 30 number list.

##### Standard Configuration Group

The standard system design allows users to select from a variety of predetermined configuration groups to support ISDN terminals.

##### Touch-Tone

Allows for Customer provided equipment to place calls on their Centrex 21 system using Dual-Tone Multi Frequency dialing.

[1] Requires CPE that has a display.

[2] Visual waiting indication available with special CPE.

## **109. OBSOLETE CENTRAL OFFICE SERVICES**

### **109.1 DIAL SWITCHING SYSTEMS**

#### **109.1.17 CENTREX 21 SERVICE (Cont'd)**

##### D. Optional Service Feature - Description

###### Additional Secondary Directory Number (SDN)

Allows more than one Secondary Directory Number to be assigned to an ISDN terminal.

###### Analog Call Appearance

This feature enables analog station users to share their call appearance on a user's ISDN station set. All Analog Call Appearances must be provisioned from the Centrex 21 central office that is providing the ISDN services. One appearance, per number, per terminal is allowed.

###### Call Park

Allows a user to hold or "Park" a call by dialing a code that can be retrieved from any station by dialing another code.

###### Caller Identification - Name and Number[1]

Allows for the automatic delivery of a calling party's name and telephone number (including nonpublished and nonlisted telephone numbers) to the called customer, which gives the called customer an opportunity to decide whether to answer the call immediately or not. The name and number are displayed on customer provided equipment.

###### Scheduled Call Forwarding[1]

Allows all incoming calls to be forwarded to another telephone number. It allows a customer to remotely change the termination of their incoming calls and base the termination upon a time schedule. From any tone signaling telephone, the customer can activate, deactivate, or change the times, days and destination numbers.

[1] For Terms and Conditions see 5.4.3, preceding.

**Qwest Corporation**  
**Exchange and Network**  
**Services Catalog No. 1**

**SECTION 109**  
Page 149  
Release 1

**SOUTHERN IDAHO**  
Issued: 7-1-2005

Effective: 8-1-2005

---

**109. OBSOLETE CENTRAL OFFICE SERVICES**

**109.1 DIAL SWITCHING SYSTEMS**

**109.1.17 CENTREX 21 SERVICE**

D. Optional Service Feature - Description (Cont'd)

Minutes Free Calling Plan

The plan includes a designated number of minutes of intraLATA toll. For all additional plan calls, the customer will be charged a special rate. The plan is available on an account level basis, where one or more lines are billed to the same account. Where the customer has one account which includes multiple lines, the plan applies to total usage of the combined lines. This plan applies only to intraLATA, dial station-to-station calls.

Remote Access Forwarding (Call Following)[1]

Allows all incoming calls to be forwarded to another telephone number. It allows the customer to remotely change the termination of their incoming calls. From any tone signaling telephone, the customer can activate, deactivate, or change the destination number.

[1] For Terms and Conditions see 5.4.3, preceding.

## **109. OBSOLETE CENTRAL OFFICE SERVICES**

### **109.1 DIAL SWITCHING SYSTEMS**

#### **109.1.17 CENTREX 21 SERVICE**

##### D. Optional Service Feature - Description (Cont'd)

###### Electronic Business Set

Electronic Set Service permits the use of special electronic station sets with Centrex Plus Service. This service utilizes a unique line card to provide communications control for the electronic station set.

The customer-provided electronic set is a touch-tone station that provides programmable keys for features and additional numbers. It is served from the central office by a main or extension station line. It has assignable keys for station line pick-ups or features. Electronic sets and adjunct modules are provided by the customer.

- Multiple Appearance Directory Number (MADN)
  - A directory number assigned to more than one electronic station set.
- Software Numbers
  - Software numbers are numbers which do not require an additional station line. These numbers share the facilities of the primary directory listed number. Variations of software numbers are:
    - Primary Appearance - The first appearance of a software number on a key.
    - Secondary Appearance - The second appearance of a software number on a key. The secondary software number can be on the same station or a different station.
    - Single Appearance - A software number that appears only on one station and one key.

###### Nonstandard Configuration Group

Allows customers to purchase additional configuration groups (beyond the five standard configuration groups provided) to support ISDN terminals.

**Qwest Corporation**  
**Exchange and Network**  
**Services Catalog No. 1**

**SECTION 109**  
Page 151  
Release 1

**SOUTHERN IDAHO**  
Issued: 7-1-2005

Effective: 8-1-2005

**109. OBSOLETE CENTRAL OFFICE SERVICES**

**109.1 DIAL SWITCHING SYSTEMS**  
**109.1.17 CENTREX 21 SERVICE (Cont'd)**

E. Rates and Charges

1. Centrex 21 Analog Station Lines

a. 2 - 5 Station Lines[1]

- Month-to-Month Feature Package
- Rate Stabilized Feature Package

USOC

FPKXX  
FPKXR

	MONTH TO MONTH	MONTHLY RATE 12 TO 36 MONTHS[2]	MONTHLY RATE 37 TO 90 MONTHS[2]
- Feature Package, each	\$19.98	\$5.39	\$3.76

[1] See rates and charges in 9.1.17, preceding

[2] Customers with service under a standard RSP that expires on or after April 11, 2005, will be billed at the rates and terms associated with the RSP period that they subscribed to until they move, disconnect the service or a change occurs in the rates or terms of the obsolete Centrex 21.

**NOTICE**  
**THE INFORMATION CONTAINED IN THIS DOCUMENT IS SUBJECT TO CHANGE.**

**Qwest Corporation**  
**Exchange and Network**  
**Services Catalog No. 1**

**SECTION 109**  
Page 152  
Release 1

**SOUTHERN IDAHO**  
Issued: 7-1-2005

Effective: 8-1-2005

**109. OBSOLETE CENTRAL OFFICE SERVICES**

**109.1 DIAL SWITCHING SYSTEMS**

**109.1.17 CENTREX 21 SERVICE**

E.1. (Cont'd)

b. 6 - 50 Station Lines

**USOC**

- Month-to-Month Station Line RXB
- Rate Stabilized Station Line RSX
- Month-to-Month Electronic Business Set Station Line EPB
- Rate Stabilized Electronic Business Set Station Line R4V

	NON- RECURRING CHARGE	MONTH TO MONTH	MONTHLY RATE	
			12 TO 36 MONTHS[1]	37 TO 90 MONTHS[1]
- Rate Group 1	\$52.00	\$26.97	\$25.46	\$25.46
- Rate Group 2	52.00	26.97	25.46	25.46

**USOC**

- Month-to-Month Feature Package FPKXX
- Rate Stabilized Feature Package FPKXR

	MONTH TO MONTH	MONTHLY RATE		
		12 TO 36 MONTHS[1]	37 TO 90 MONTHS[1]	
- Feature Package, each		\$19.98	\$5.39	\$3.76

[1] Customers with service under a standard RSP that expires on or after April 11, 2005, will be billed at the rates and terms associated with the RSP period that they subscribed to until they move, disconnect the service or a change occurs in the rates or terms of the obsolete Centrex 21.

**NOTICE**  
**THE INFORMATION CONTAINED IN THIS DOCUMENT IS SUBJECT TO CHANGE.**

**Qwest Corporation**  
**Exchange and Network**  
**Services Catalog No. 1**

**SECTION 109**  
Page 153  
Release 1

**SOUTHERN IDAHO**  
Issued: 7-1-2005

Effective: 8-1-2005

**109. OBSOLETE CENTRAL OFFICE SERVICES**

**109.1 DIAL SWITCHING SYSTEMS**

**109.1.17 CENTREX 21 SERVICE**

E. Rates and Charges (Cont'd)

2. Centrex 21 ISDN 2B+S,  
(digital, voice only) line

**USOC**

- 2 - 50, lines each

**XRW, XRS**

NON- RECURRING CHARGE	MONTH TO MONTH	MONTHLY RATE	
		12 TO 36 MONTHS[1]	37 TO 90 MONTHS[1]
\$110.00	\$68.00	\$64.60	\$61.20

3. Miscellaneous Charges

- Nonrecurring charges apply, per Centrex 21 station line, per customer group.

	<b>USOC</b>	<b>NONRECURRING CHARGE</b>
- Centrex 21 system change charge per station line changed	NRC62	\$ 5.00
• Conversion Charge, per each existing line converted from a Company Access Line to Centrex 21 Service[2]	NR9CE	12.00

[1] Customers with service under a standard RSP that expires on or after April 11, 2005, will be billed at the rates and terms associated with the RSP period that they subscribed to until they move, disconnect the service or a change occurs in the rates or terms of the obsolete Centrex 21.

[2] NR9CE applies in place of the initial Centrex 21 station line nonrecurring charge. The Conversion Charge does not apply to 60 Month contracts.

**NOTICE**  
**THE INFORMATION CONTAINED IN THIS DOCUMENT IS SUBJECT TO CHANGE.**

**Qwest Corporation**  
**Exchange and Network**  
**Services Catalog No. 1**

**SECTION 109**  
Page 154  
Release 1

**SOUTHERN IDAHO**  
Issued: 7-1-2005

Effective: 8-1-2005

**109. OBSOLETE CENTRAL OFFICE SERVICES**

**109.1 DIAL SWITCHING SYSTEMS**

**109.1.17 CENTREX 21 SERVICE**

E. Rates and Charges (Cont'd)

4. Optional Service Features

	<b>USOC</b>	<b>NONRECURRING CHARGE</b>	<b>MONTHLY RATE</b>
a. Additional Secondary Directory Number (SDN)			
• Per station line	A6QPN	\$12.00	\$1.00
b. Analog Call Appearance			
• Per number, per terminal	MAZ	12.00	1.00
c. Call Park			
• Per station line	C4Z	5.00	1.00
d. 2B+D (Circuit Switched Data)	[1]	[1]	[1]
e. Caller Identification Name and Number			
• Per line	NNK	–	3.50
f. Remote Access Forwarding			
• Per line	AFD	–	7.45
g. Scheduled Call Forwarding			
• Per line	ATF	–	8.45

[1] See USOC's, rates and charges found in 14.2.1, following, for Single Line ISDN Service.

**Qwest Corporation**  
**Exchange and Network**  
**Services Catalog No. 1**

**SECTION 109**  
Page 155  
Release 1

**SOUTHERN IDAHO**  
Issued: 7-1-2005

Effective: 8-1-2005

**109. OBSOLETE CENTRAL OFFICE SERVICES**

**109.1 DIAL SWITCHING SYSTEMS**

**109.1.17 CENTREX 21 SERVICE**

E.4. (Cont'd)

	<b>USOC</b>	<b>NONRECURRING CHARGE</b>	<b>MONTHLY RATE</b>
h. Electronic Business Set			
• Electronic set service interface, per main station line[1]	PP3	[2]	[2]
• Primary appearance of a software number	SO3	[2]	[2]
• Subsequent appearance of a software number	SO5	[2]	–
• Single appearance of a software number	SFB	[2]	[2]
• Adjunct module, per module[3]	C2TAX	[2]	[2]
i. Nonstandard Configuration Group			
• Per configuration group, per system	N3CPG	\$100.00	–

[1] Includes electronic set service standard features.

[2] See rates and charges for Electronic Set Service found in 109.1.16, preceding.

[3] In addition, rates and charges specified above for primary directory number appearances and software number appearances apply.

**NOTICE**  
**THE INFORMATION CONTAINED IN THIS DOCUMENT IS SUBJECT TO CHANGE.**

**Qwest Corporation**  
**Exchange and Network**  
**Services Catalog No. 1**

**SECTION 109**  
Page 156  
Release 1

**SOUTHERN IDAHO**  
Issued: 7-1-2005

Effective: 8-1-2005

**109. OBSOLETE CENTRAL OFFICE SERVICES**

**109.1 DIAL SWITCHING SYSTEMS**

**109.1.17 CENTREX 21 SERVICE**

E.4. (Cont'd)

		USOC	NONRECURRING CHARGE	MONTHLY RATE
j. Minutes Free Calling Plan				
			RATE PERIOD	
		USOC	INITIAL (30 SEC)	ADDNL (6 SEC.)
			MINUTES	
		OBK5X	0 - 100	-
			101 and over	\$0.045      \$0.009

NOTICE  
THE INFORMATION CONTAINED IN THIS DOCUMENT IS SUBJECT TO CHANGE.

**Qwest Corporation**  
**Exchange and Network**  
**Services Catalog No. 1**

**SECTION 109**  
Page 156.1  
Release 1  
Effective: 3-6-2006

**SOUTHERN IDAHO**  
Issued: 2-24-2006

**109. OBSOLETE CENTRAL OFFICE SERVICES**

**109.2 EMERGENCY REPORTING SERVICE**

(N)

**109.2.1 UNIVERSAL EMERGENCY NUMBER SERVICE – 911**

A. Wireless E9-1-1 Connectivity[1]

See Section 9.2.1 for description, terms and conditions.

(N)

1. *CELLTRACE*

(T)(M)

- a. Effective March 6, 2006, *CELLTRACE* is obsolete and is not available to new customers. Customers will be allowed to retain *CELLTRACE* only as long as service remains at the same location for the same customer and for as long as the Company can obtain the parts to repair the service.

(N)

(N)

- b. *CELLTRACE* is a hybrid call associated signal (HCAS) solution within the Company E9-1-1 Control Office that provides for the forwarding of ANI from a wireless handset to a PSAP. A call to 911 from a wireless handset is passed from the Mobile Switching Center (MSC) to the Company's selective routing switch on dedicated facilities. Upon completing the call to the PSAP, the cell site location and the number of the originating call are displayed on the PSAP's ALI display device.

(T)(M1)

(M1)

2. Definitions

(T-M)

*CELLTRACE* Interface

(M1)

A non-blocking trunk signaling device which automatically provides the PSAP with the caller's wireless handset ten digit ANI, the location of the cell site that originated the call and the name of the wireless service provider. This information is then delivered to the 9-1-1 database.

(M1)

- [1] Per FCC Report and Order 94-102, the Carrier must at least route a wireless caller's E9-1-1 call to the nearest PSAP and deliver the associated ten-digit wireless handset telephone number, the cell site and the sector.

(M)

(M)

(M) Material duplicated from 9.2.1.

(M1) Material moved from 9.2.1.

NOTICE  
THE INFORMATION CONTAINED IN THIS DOCUMENT IS SUBJECT TO CHANGE.

**Qwest Corporation**  
Exchange and Network  
Services Catalog No. 1

**SECTION 109**  
Page 156.2  
Release 1  
Effective: 3-6-2006

**SOUTHERN IDAHO**  
Issued: 2-24-2006

**109. OBSOLETE CENTRAL OFFICE SERVICES**

**109.2 EMERGENCY REPORTING SERVICE**

**109.2.1 UNIVERSAL EMERGENCY NUMBER SERVICE – 911**

A. Wireless E9-1-1 Connectivity[1] (Cont'd)

3. Rates and Charges

	<b>USOC</b>	<b>NONRECURRING CHARGE</b>	<b>MONTHLY RATE</b>	(N)
• <i>CELLTRACE</i> Interface[1]	9AN	ICB	ICB	(N)   (N)  (T-M)

[1] Rates and Charges based on an individual customer case by case basis. (M1)

(M) Material moved from 9.2.1.

(M1) Material duplicated from 9.2.1.

NOTICE  
THE INFORMATION CONTAINED IN THIS DOCUMENT IS SUBJECT TO CHANGE.

**Qwest Corporation**  
**Exchange and Network**  
**Services Catalog No. 1**

**SECTION 109**

Page 157

Release 2

**SOUTHERN IDAHO**  
Issued: 2-24-2006

Effective: 3-6-2006

**109. OBSOLETE CENTRAL OFFICE SERVICES**

**109.2 EMERGENCY REPORTING SERVICE (Cont'd)**

(T)

**109.2.3 EMERGENCY ALARM AND REPORTING SERVICE**

**A. Public Emergency Reporting Service - Small Office**

**1. Description**

- a. Public Emergency Reporting Service is designed for use of police and volunteer fire departments, etc., in small manual and community dial exchanges. The system is arranged so that the line associated with the telephone number designated to receive fire or other emergency reporting calls may be terminated in a number of telephones at various locations in the exchange. This arrangement will permit a number of people to receive emergency calls and sound the alarm where required.
- b. The telephone lines are not used for regular exchange telephone service. Telephones may be equipped with a signal key to actuate the customer-provided remote warning signal.
- c. A maximum of 10 telephones may be provided on a system. The telephone line at the location where emergency calls are generally received is the main station lines. Telephone lines at all additional emergency reporting locations are considered extension station lines. Control equipment may be used to actuate a maximum of four remote signals.
- d. The customer releases, indemnifies and holds harmless the Company from any and all loss, claims, demands, suits, or other action, or any liability whatsoever, whether suffered, made, instituted or asserted by the customer or by any other party or person, for any personal injury to or death of any person or persons, or for any loss, damage or destruction of any property, whether owned by the customer or others, caused or claimed to have been caused directly or indirectly by the installation, operation, failure to operate, maintenance, removal, presence, condition, location or use of equipment or facilities associated with this service.

**Qwest Corporation**  
**Exchange and Network**  
**Services Catalog No. 1**

**SECTION 109**  
Page 158  
Release 1

**SOUTHERN IDAHO**  
Issued: 7-1-2005

Effective: 8-1-2005

**109. OBSOLETE CENTRAL OFFICE SERVICES**

**109.2 EMERGENCY REPORTING SERVICE**

**109.2.3 EMERGENCY ALARM AND REPORTING SERVICE**

A. Public Emergency Reporting Service - Small Office (Cont'd)

2. Rates and Charges

a. Public Emergency Reporting Service - Small Office

- b. Where the customer-owned signal is not on the same premises as one of the emergency reporting telephones, regular Exchange Service Extension charges will apply to the circuit to the signal location.
- c. Rates and charges, for Public Emergency Reporting Service, do not include provision of telephones nor signal control equipment.
- d. Regular Exchange Service Extension charges apply for telephones at additional reporting locations.

	<b>USOC</b>	<b>SERVICE &amp; EQUIPMENT CHARGE</b>	<b>MONTHLY RATE</b>
• Common equipment at the CO to actuate remote signal control equipment, each	PN8	\$11.00	\$3.23

**NOTICE**  
**THE INFORMATION CONTAINED IN THIS DOCUMENT IS SUBJECT TO CHANGE.**

**Qwest Corporation**  
**Exchange and Network**  
**Services Catalog No. 1**

**SECTION 109**  
Page 159  
Release 1

**SOUTHERN IDAHO**  
Issued: 7-1-2005

Effective: 8-1-2005

**109. OBSOLETE CENTRAL OFFICE SERVICES**

**109.2 EMERGENCY REPORTING SERVICE**

**109.2.3 EMERGENCY ALARM AND REPORTING SERVICE**

A.2.d. (Cont'd)

Main telephone line at emergency reporting headquarters:

	<b>USOC</b>	<b>NONRECURRING CHARGE</b>	<b>MONTHLY ACCESS RATE GROUP</b>	
			<b>1</b>	<b>2</b>
• Each line	1VS	\$52.00	\$11.63	\$17.17

Message Unit Charge

The following message charge applies for calls places within exchanges in the same local calling area.

	<b>CHARGE FOR EACH MESSAGE</b>
• Business	\$0.096

**NOTICE**  
**THE INFORMATION CONTAINED IN THIS DOCUMENT IS SUBJECT TO CHANGE.**

**Qwest Corporation**  
**Exchange and Network**  
**Services Catalog No. 1**

**SECTION 109**  
Page 160  
Release 1

**SOUTHERN IDAHO**  
Issued: 7-1-2005

Effective: 8-1-2005

**109. OBSOLETE CENTRAL OFFICE SERVICES**

**109. EMERGENCY REPORTING SERVICE**

**109.2.3 EMERGENCY ALARM AND REPORTING SERVICE (Cont'd)**

B. Command Conference Service

1. General

- a. Command Conference Service is an alarm system designed for use in cities employing a few full-time firemen, including a dispatcher and a volunteer force. The system provides a flexible arrangement which enables a dispatcher, at the fire reporting location, to call a group of firemen, or selected individual, or groups at one time. The service arrangement may also be provided for a customer in connection with private branch exchange service.
- b. Each command conference equipment unit will accommodate a maximum of twenty-one conference stations. The conference units may be combined where there is a requirement for larger conference groups.
- c. The station equipment at the dispatcher's location may consist of a multiline telephone set or it may be associated with 101 key equipment or private branch exchange switchboard equipment where this equipment is required in connection with other service.
- d. An individual line service or a private branch exchange main station line is required at the location of each volunteer fireman to be called. The line is connected to the command conference unit at the central office or at the location of the private branch exchange switching equipment.
- e. The customer release, indemnifies and holds harmless the Company from any and all loss, claims, demands, suits or other action, or any liability whatsoever, whether suffered, made, instituted or asserted by the customer or by any other party or person, for any personal injury to or death of any person or persons, or for any loss, damage or destruction of any property, whether owned by the customer or others, caused or claimed to have been caused directly or indirectly by the installation, operation, failure to operate, maintenance, removal, presence, condition, location or use of equipment or facilities associated with this service.

**NOTICE**  
**THE INFORMATION CONTAINED IN THIS DOCUMENT IS SUBJECT TO CHANGE.**

**Qwest Corporation**  
**Exchange and Network**  
**Services Catalog No. 1**

**SECTION 109**  
Page 161  
Release 1

**SOUTHERN IDAHO**  
Issued: 7-1-2005

Effective: 8-1-2005

**109. OBSOLETE CENTRAL OFFICE SERVICES**

**109.2 EMERGENCY REPORTING SERVICE**

**109.2.3 EMERGENCY ALARM AND REPORTING SERVICE**

B. Command Conference Service (Cont'd)

2. Rates and Charges

- a. The following rates and charges are in addition to the regular rates and charges for the exchange access service with which the command conference service is associated.

	<b>USOC</b>	<b>INSTALLATION CHARGE</b>	<b>MONTHLY RATE</b>
Talk and control circuit from the dispatcher's station to the command conference equipment. One pair is required for each conference system with up to 63 station lines, each circuit	N/A	[1]	[1]
One ringing circuit from the dispatcher's station to the location of the command conference equipment is required for each 21 station conference unit, ringing circuit, each	N/A	[2]	[2]

[1] See the Access Service Catalog for rates and charges for Voiceband/Data Circuit.

[2] Exchange Service Extension rates and charges, see the Access Service Catalog.

**NOTICE**  
**THE INFORMATION CONTAINED IN THIS DOCUMENT IS SUBJECT TO CHANGE.**

**Qwest Corporation**  
**Exchange and Network**  
**Services Catalog No. 1**

**SECTION 109**  
Page 162  
Release 1

**SOUTHERN IDAHO**  
Issued: 7-1-2005

Effective: 8-1-2005

---

**109. OBSOLETE CENTRAL OFFICE SERVICES**

**109.8 CENTRAL OFFICE ALARM SERVICES**

**109.8.1 *VERSANET* SERVICE**

A. Definitions

Patron

The alarm agency's customer who has subscribed to *VERSANET* Service offered by the alarm agency.

Alarm Agency

Retailer who subscribes to *VERSANET* Service and provides alarm service to the patrons.

NOTICE  
THE INFORMATION CONTAINED IN THIS DOCUMENT IS SUBJECT TO CHANGE.

**Qwest Corporation**  
**Exchange and Network**  
**Services Catalog No. 1**

**SECTION 109**  
Page 163  
Release 1

**SOUTHERN IDAHO**  
Issued: 7-1-2005

Effective: 8-1-2005

**109. OBSOLETE CENTRAL OFFICE SERVICES**

**109.8 CENTRAL OFFICE ALARM SERVICES**

**109.8.1 VERSANET SERVICE**

A. Definitions (Cont'd)

Shared Scanner Service

Accommodates up to 26 alarm agencies per scanner shelf. Any number of shelves may be placed in a central office. When an alarm or line status change is detected, alarm and patron information is transported to the proper agency. Transmission from the scanner shelf is provided over exchange network access facilities.

**SYSTEM OPERATION**

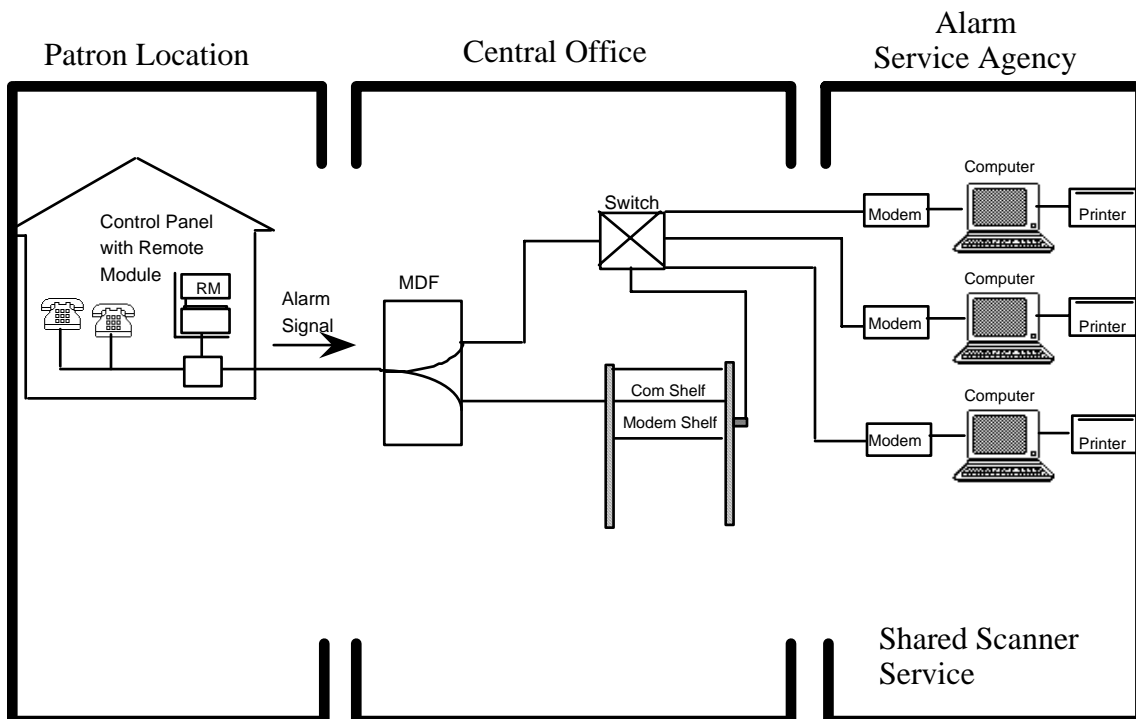

**NOTICE**  
THE INFORMATION CONTAINED IN THIS DOCUMENT IS SUBJECT TO CHANGE.

**109. OBSOLETE CENTRAL OFFICE SERVICES**

**109.8 CENTRAL OFFICE ALARM SERVICES**

**109.8.1 VERSANET SERVICE**

A. Definitions (Cont'd)

Dedicated Scanner Service

Utilizes a custom scanner shelf for the alarm agency's exclusive use. Transmission from the scanner shelf can be provided over exchange network access or private line facilities.

**SYSTEM OPERATION**

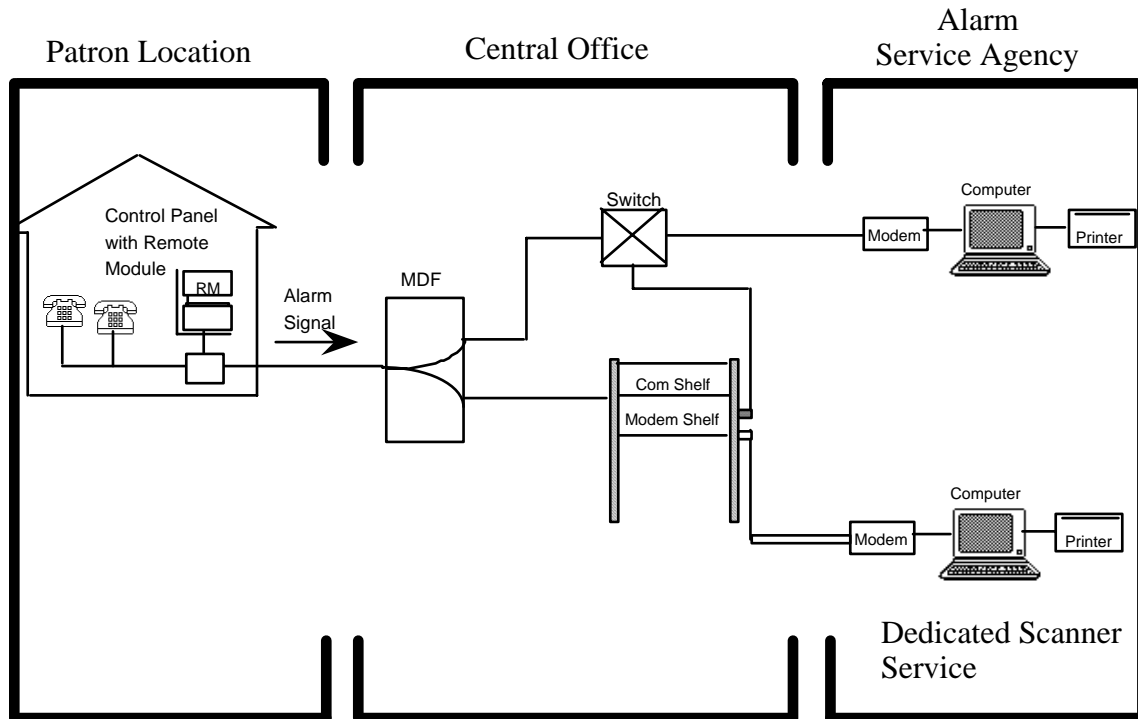

**NOTICE**  
THE INFORMATION CONTAINED IN THIS DOCUMENT IS SUBJECT TO CHANGE.

**Qwest Corporation**  
**Exchange and Network**  
**Services Catalog No. 1**

**SECTION 109**  
Page 165  
Release 1  
Effective: 8-1-2005

**SOUTHERN IDAHO**  
Issued: 7-1-2005

**109. OBSOLETE CENTRAL OFFICE SERVICES**

**109.8 CENTRAL OFFICE ALARM SERVICES**

**109.8.1 VERSANET SERVICE (Cont'd)**

B. Description

1. *VERSANET* Service receives low speed data signals over exchange access lines from the patron's premises to the alarm agency via the central office. This low speed data signal does not interfere with the patron's normal telephone usage.
2. If the telephone line is severed either by accidental or intentional cutting this condition is sensed by the central office equipment, and an alarm is generated to the alarm vendor's central station or monitoring agency.

C. Regulations

1. *VERSANET* Service will be provided only on individual exchange access line service, between the patron's location and serving central office.
2. *VERSANET* Service is offered only on end-to-end metallic facilities and only in central offices with line appearance capability. The Company reserves the right to designate the central offices and areas from which this service may be provided. It is expressly declared that metallic facilities are in continually decreasing supply and the Company is not obligated to continue to provide such facilities. Due to facility rearrangements, continued use of metallic facilities may be denied to existing customers with no obligation on the Company's part to pay customer equipment rearrangement costs. The Company will give the customer 90 days notification of modifications impacting the continued availability of *VERSANET* Service.
3. The initial contract period for the alarm agency subscribing to *VERSANET* Service is 1-3 years for shared scanner service and 60 months for dedicated scanner service. The Company does not install, provide or maintain the patron's alarm sensors needed to provide the service.
4. Prior to the Company placing a shared scanner shelf, a minimum of 25 subscribers of the alarm agency is required.
5. The alarm agency is responsible for compliance with Part 68 of the FCC Rules and Regulations.
6. The alarm agency must submit to the Company the name of the patron and telephone number to be connected and disconnected to the service.

**NOTICE**  
**THE INFORMATION CONTAINED IN THIS DOCUMENT IS SUBJECT TO CHANGE.**

**Qwest Corporation**  
**Exchange and Network**  
**Services Catalog No. 1**

**SECTION 109**  
Page 165  
Release 1

**SOUTHERN IDAHO**  
Issued: 7-1-2005

Effective: 8-1-2005

**109. OBSOLETE CENTRAL OFFICE SERVICES**

**109.8 CENTRAL OFFICE ALARM SERVICES**

**109.8.1 VERSANET SERVICE**

C. Regulations (Cont'd)

7. In the event the patron's telephone service is terminated for any reason *VERSANET* Service will also be terminated. The alarm agency will be notified in writing.
8. The alarm agency does not have exclusive rights or use of the patron's access line.
9. All calls to the alarm agency that are generated by the central office scanner, due to change in the alarm status on a patron's line, must be toll free, i.e. a local telephone number or 800/800-type service.
10. *VERSANET* Service is not available with the following services:
  - WATS lines
  - FX lines
  - FCO lines
  - Combination main station service
  - Ground Start Services
  - Party lines
11. Suspension of service is not offered for *VERSANET* Service. The suspension of basic exchange service used in connection with *VERSANET* Service will result in the disconnection of the associated *VERSANET* Service.

D. Liability

The Company's liability to any patron or alarm agency for interruption or failure of *VERSANET* Service is as set forth in Section 2 of this Catalog.

E. Indemnification

The alarm agency agrees to indemnify, hold harmless and to defend the Company, its agents and employees, from any and all claims, actions, losses, damages, expenses and other liabilities including, but not limited to, claims against the Company for personal injury, property damage, or any other damage or loss, and reasonable attorney fees and costs of litigation, arising out of any act or omission of the alarm company in connection with the service, including any claim, damage or loss arising out of the manufacturing, offering, sale or other provision of products or services by the alarm agency.

**NOTICE**  
**THE INFORMATION CONTAINED IN THIS DOCUMENT IS SUBJECT TO CHANGE.**

**Qwest Corporation**  
**Exchange and Network**  
**Services Catalog No. 1**

**SECTION 109**  
Page 167  
Release 1

**SOUTHERN IDAHO**  
Issued: 7-1-2005

Effective: 8-1-2005

**109. OBSOLETE CENTRAL OFFICE SERVICES**

**109.8 CENTRAL OFFICE ALARM SERVICES**

**109.8.1 VERSANET SERVICE (Cont'd)**

F. Rates and Charges

1. When a trouble report placed by the patron (or alarm agency on behalf of the patron) requires a premises visit and the trouble is due to the *VERSANET* Service equipment, Premises Work Charges will apply to the patron.
2. The following rates and charges apply and will be billed to the alarm agency:

	<b>USOC</b>	<b>SERVICE &amp; EQUIPMENT CHARGE</b>	<b>MONTHLY RATE</b>
• Shared Scanner Service			
- Patron line connection	WRN	\$13.50	\$ 2.31
- Port and modem connection and pro rata charge of shared scanner shelf, per patron line	WNSEP	14.00	5.69
• Dedicated Scanner Service			
- Patron line connection	WRN	13.50	2.31
- Port and modem connection, per patron line	WNA	14.00	2.69
- Alarm agency dedicated scanner shelf, per shelf	WNSS1	-	100.00

**NOTICE**  
**THE INFORMATION CONTAINED IN THIS DOCUMENT IS SUBJECT TO CHANGE.**